



Standard Practice for Operation of the Vettermann Drum Tester¹

This standard is issued under the fixed designation D5417; the number immediately following the designation indicates the year of original adoption or, in the case of revision, the year of last revision. A number in parentheses indicates the year of last reappraisal. A superscript epsilon (ϵ) indicates an editorial change since the last revision or reappraisal.

1. Scope

1.1 This practice describes the equipment and operation of the Vettermann drum tester for testing pile yarn floor covering to produce changes in appearance and color due to changes in surface structure by mechanical action.

1.2 This practice is only applicable for use in testing unused pile floor covering of all types. It is not applicable for use in testing used pile yarn floor coverings.

1.3 The values stated in inch-pound units are to be regarded as standard. The values given in parentheses are mathematical conversions to SI units that are provided for information only and are not considered standard.

1.4 *This standard does not purport to address all of the safety concerns, if any, associated with its use. It is the responsibility of the user of this standard to establish appropriate safety and health practices and determine the applicability of regulatory limitations prior to use.*

2. Referenced Documents

- 2.1 *ASTM Standards:*²
 - D123 Terminology Relating to Textiles
 - D1776 Practice for Conditioning and Testing Textiles
 - D5684 Terminology Relating to Pile Floor Coverings

3. Terminology

3.1 For definitions of terms relating to Pile Floor Coverings, D13.21, refer to Terminology D5684.

3.1.1 The following terms are relevant to this standard: carpet, finished, finished pile yarn floor covering, floor covering, lengthwise direction, pile, pile lay, pile yarn floor covering, pitch, practice, primary backing, secondary backing, textile floor covering, texture, tufted fabric.

3.2 For all other terminology related to textiles, refer to Terminology D123.

¹ This practice is under the jurisdiction of ASTM Committee D13 on Textiles and is the direct responsibility of Subcommittee D13.21 on Pile Floor Coverings.

Current edition approved Jan. 1, 2016. Published January 2016. Originally approved in 1999. Last previous edition approved in 2011 as D5417-11. DOI: 10.1520/D5417-16.

² For referenced ASTM standards, visit the ASTM website, www.astm.org, or contact ASTM Customer Service at service@astm.org. For *Annual Book of ASTM Standards* volume information, refer to the standard's Document Summary page on the ASTM website.

4. Summary of Practice

4.1 The test specimen is mounted in the rotatable drum with the pile surface towards the center of the drum and the edges under the retaining segments. A steel ball, with 14 rubber studs rolls randomly inside the drum on the pile surface for a specified number of revolutions.

5. Significance and Use

5.1 This equipment may be used to bring about the changes in texture on the surface of pile floor covering caused by mechanical action.

5.2 The acceptance criteria of this practice shall be set by mutual agreement between the purchaser and the supplier.

6. Apparatus and Material

6.1 *Vettermann Drum Tester* (See Fig. 1):

6.1.1 *Drum*, incorporating a revolution counter and four adjustable retaining segments (thickness: 0.60 ± 0.03 in. (15 ± 1 mm)) on each side wall of the drum. A free-running circular brush mounted in such a way that it lightly contacts the surface of specimens and loose fibers are continuously extracted by a vacuum cleaner. A vulcanized fiber backing sheet 93.3 by 10.6 by 0.06 in. (2320 by 270 by 1.5 mm) is loosely laid inside the drum. This sheet remains permanently in the drum.

6.1.2 The Vettermann drum dimensions are as follows:

Internal diameter	28.70 ± 0.39 in.	(730 ± 10 mm)
Internal depth	10.60 ± 0.20 in.	(270 ± 5 mm)
Effective depth	9.40 ± 0.28 in.	(240 ± 7 mm)
Thickness of curved surface	0.31 ± 0.02 in.	(8 ± 0.5 mm)

6.1.3 *Driving System*, with a speed of 1.65 rad/s (16 ± 1 rpm) and the direction of rotation is reversed every five minutes, stopping between reversals for approximately 1 s time intervals, with approximately one second stationary time.

6.1.4 *Protective Cage*, fits over the drum and must be in place prior to Vettermann drum rotation.

6.1.5 *Round Steel Ball*, fitted with fourteen cylindrical rubber studs located equally spaced on the ball surface. The studs are replaceable and are screwed into flat faces on the surface of the ball. (See Fig. 2.):

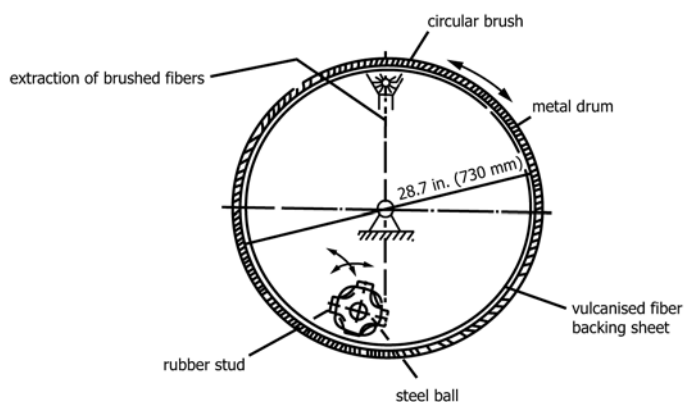

FIG. 1 Vettermann Drum Tester

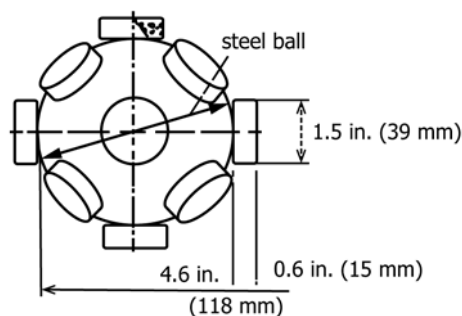

FIG. 2 Round Steel Ball

Diameter of ball	4.70 ± 0.01 in.	(120.0 ± 0.2 mm)
Distance between diametrically opposed flat stud-mounting faces	4.60 ± 0.01 in.	(118.0 ± 0.1 mm)
Mass without studs	15.0 ± 0.2 lb	(6800 ± 100 g)
Mass with studs	16.8 ± 0.2 lb	(7600 ± 100 g)

6.1.6 *Replaceable Rubber Studs*, are a composite rubber disk attached to a steel backing plate with integral mounting screw. The dimensions are:

Diameter	1.54 ± 0.02 in.	(39.0 ± 0.5 mm)
Total height including backing plate	0.59 ± 0.02 in.	(15.0 ± 0.5 mm)
Thickness of steel backing plate	0.12 in.	(3 mm)
Rubber hardness	48 ± 3	Type A

6.1.6.1 The studs must be replaced after 500 000 revolutions of the drum. Unscrew the old studs and replace with new studs ensuring that each stud is properly tightened. Place disposable specimens in the drum tester and condition the new studs by running the tester for 10 000 revolutions with the steel ball inside.

6.1.7 *Vacuum Cleaner*, upright type, with a rotating brush and beater bar, unless this type of apparatus is not recommended by the manufacturer of the pile floor covering under test, in that case the appropriate recommended device should be used.

6.1.8 *Cleaning Frame*, with a central rectangular aperture to receive the test specimen. The frame should be the same material as the test specimen or similar in construction to the test specimen. To ensure proper cleaning by the vacuum cleaner, it is recommended the frame and test specimen be mounted on a rigid backing sheet.

7. Reagent

7.1 *Solvent*—Ethyl alcohol ((CH₃)₂CHOH) or technical grade iso-propyl alcohol (CH₃)₂CHOH) are suitable. Do not use cellosolve, chlorinated or ketone solvents.

8. Preparation of Specimen

8.1 *Marking Specimen*—Before cutting out the test specimen, mark on the secondary backing the direction of manufacture with the head of the arrow pointing in the same direction as the lay of the pile.

8.2 *Size of Specimen*—Cut the specimen approximately 22.4 by 10.4 in. (570 by 265 mm). The long dimension shall be parallel to the lengthwise direction of the carpet. Take no specimen within 4 in. (100 mm) of the trimmed selvage.

8.2.1 When testing thick pile floor covering, it may be necessary to shorten the specimen length to approximately 22 in. (565 mm).

8.3 *Preparation*—Clean the specimen with an upright vacuum cleaner, condition it flat with pile surface up for a minimum of 12 h.

9. Conditioning

9.1 Condition the specimen in the standard atmosphere for testing textiles in accordance with Practice D1776.

10. Procedure

10.1 Perform this practice on a specimen prepared as described in Section 9, maintaining the Vettermann drum test in the standard atmosphere for testing textiles as per Practice D1776.

10.2 Remove the protective cage from the tester.

10.3 Loosen the outside bolts.

10.4 Wipe the inside of the drum and the steel ball with a clean lint free tissue and one of the recommended reagents.

10.5 Inspect the rubber studs on the steel ball for signs of wear or damage and replace as needed.

10.6 Fit the test specimen into the drum with the pile surface towards the center of the drum and the edges under the retaining segments and clamp into place by tightening the bolt.

10.7 Place the steel ball in the drum on the pile surface.

10.8 Replace the protective cage over the Vettermann drum.

10.9 Set the revolution counter to the desired number of cycles (Note 1) and switch on the machine. When the machine stops, loosen the bolts, remove the mounted specimen and place in the central aperture of the cleaning frame.

10.10 Using the upright vacuum cleaner, make four forward and four backward passes along the length of the mounted

specimen ensuring all the area is covered and the final pass is in the lay of the pile and condition the specimen for a minimum of 24 h.

NOTE 1—Common practice in the pile floor industry is the use of 22 000 cycles for commercial and 5000 cycles for residential constructions. Other cycle counts may result from mutual agreement between purchaser and supplier.

11. Report

11.1 Report the following information:

11.1.1 State that the test was conducted as directed in this practice (D5417),

11.2 Identify the tested specimen,

11.3 Report the atmospheric conditions, if other than standard,

11.4 Report the number of revolutions,

11.5 Report the type of vacuum cleaner used, and

11.6 Detail any deviations from this practice.

12. Keywords

12.1 appearance; floor covering

ASTM International takes no position respecting the validity of any patent rights asserted in connection with any item mentioned in this standard. Users of this standard are expressly advised that determination of the validity of any such patent rights, and the risk of infringement of such rights, are entirely their own responsibility.

This standard is subject to revision at any time by the responsible technical committee and must be reviewed every five years and if not revised, either reapproved or withdrawn. Your comments are invited either for revision of this standard or for additional standards and should be addressed to ASTM International Headquarters. Your comments will receive careful consideration at a meeting of the responsible technical committee, which you may attend. If you feel that your comments have not received a fair hearing you should make your views known to the ASTM Committee on Standards, at the address shown below.

This standard is copyrighted by ASTM International, 100 Barr Harbor Drive, PO Box C700, West Conshohocken, PA 19428-2959, United States. Individual reprints (single or multiple copies) of this standard may be obtained by contacting ASTM at the above address or at 610-832-9585 (phone), 610-832-9555 (fax), or service@astm.org (e-mail); or through the ASTM website (www.astm.org). Permission rights to photocopy the standard may also be secured from the Copyright Clearance Center, 222 Rosewood Drive, Danvers, MA 01923, Tel: (978) 646-2600; <http://www.copyright.com/>