



# Standard Test Methods for Measurement of Water Levels in Open-Water Bodies<sup>1</sup>

This standard is issued under the fixed designation D5413; the number immediately following the designation indicates the year of original adoption or, in the case of revision, the year of last revision. A number in parentheses indicates the year of last reapproval. A superscript epsilon ( $\epsilon$ ) indicates an editorial change since the last revision or reapproval.

## 1. Scope

1.1 These test methods cover equipment and procedures used in obtaining water levels of rivers, lakes, and reservoirs or other water bodies. Three types of equipment are available as follows:

Test Method A—Nonrecording water-level measurement devices  
Test Method B—Recording water-level measurement devices  
Test Method C—Remote-interrogation water-level measurement devices

1.2 The procedures detailed in these test methods are widely used by those responsible for investigations of streams, lakes, reservoirs, and estuaries, for example, the U.S. Agricultural Research Service, the U.S. Army Corp of Engineers, and the U.S. Geological Survey.<sup>2</sup> The referenced ISO standard also furnishes useful information.

1.3 It is the responsibility of the user of these test methods to determine the acceptability of a specific device or procedure to meet operational requirements. Compatibility between sensors, recorders, retrieval equipment, and operational systems is necessary, and data requirements and environmental operating conditions must be considered in equipment selection.

1.4 The values stated in inch-pound units are to be regarded as the standard. The values given in parentheses are for information only.

1.5 *This standard does not purport to address all of the safety concerns, if any, associated with its use. It is the responsibility of the user of this standard to establish appropriate safety and health practices and determine the applicability of regulatory limitations prior to use.*

<sup>1</sup> These test methods are under the jurisdiction of ASTM Committee D19 on Water and is the direct responsibility of Subcommittee D19.07 on Sediments, Geomorphology, and Open-Channel Flow.

Current edition approved Jan. 1, 2013. Published January 2013. Originally approved in 1993. Last previous edition approved in 2007 as D5413 – 93 (2007). DOI: 10.1520/D5413-93R13.

<sup>2</sup> Buchanan, T. J., and Somers, W. P., "Stage Measurement at Gauging Stations," Techniques of Water Resources Investigations, Book 3, Chapter A-7, U.S. Geological Survey, 1968.

## 2. Referenced Documents

### 2.1 ASTM Standards:<sup>3</sup>

D1129 Terminology Relating to Water  
D1941 Test Method for Open Channel Flow Measurement of Water with the Parshall Flume  
D2777 Practice for Determination of Precision and Bias of Applicable Test Methods of Committee D19 on Water  
D5242 Test Method for Open-Channel Flow Measurement of Water with Thin-Plate Weirs

### 2.2 ISO Standard:<sup>4</sup>

ISO 4373 Measurement of Liquid Flow in Open Channels—Water Level Measuring Devices

## 3. Terminology

3.1 *Definitions*—For definitions of terms used in these test methods, refer to Terminology

### 3.2 Definitions of Terms Specific to This Standard:

3.2.1 *elevation*—the vertical distance from a datum to a point.

3.2.2 *datum*—a level plane that represents a zero or some defined elevation.

3.2.3 *gauge*—a generic term that includes water level measuring devices.

3.2.4 *gauge datum*—a datum whose surface is at the zero elevation of all the gauges at a gauging station; this datum is often at a known elevation referenced to National Geodetic Vertical Datum of 1929 (NGVD).

3.2.5 *gauge height*—the height of a water surface above an established or arbitrary datum at a particular gauging station; also termed stage.

3.2.6 *gauging station*—a particular site on a stream, canal, lake, or reservoir where systematic observations of hydrologic data are obtained.

<sup>3</sup> For referenced ASTM standards, visit the ASTM website, www.astm.org, or contact ASTM Customer Service at service@astm.org. For *Annual Book of ASTM Standards* volume information, refer to the standard's Document Summary page on the ASTM website.

<sup>4</sup> Available from American National Standards Institute (ANSI), 25 W. 43rd St., 4th Floor, New York, NY 10036, http://www.ansi.org.

3.2.7 *National Geodetic Vertical Datum of 1929 (NGVD)*—prior to 1973 known as mean sea level datum; a spheroidal datum in the conterminous United States and Canada that approximates mean sea level but does not necessarily agree with sea level at a specific location.

**4. Significance and Use**

4.1 These test methods are used to determine the gauge height or elevation of a river or other body of water above a given datum.

4.2 Water level data can serve as an easily recorded parameter, and through use of a stage-discharge relation provide an indirect value of stream discharge, often at a gauging station.

4.3 These test methods can be used in conjunction with other determinations of biological, physical, or chemical properties of waters.

**TEST METHOD A—NONRECORDING WATER-LEVEL MEASUREMENT DEVICES**

**5. Summary of Test Method**

5.1 These test methods are usually applicable to conditions where continuous records of water level or discharge are not required. However, in some situations, daily or twice daily observations from a nonrecording water-level device can provide a satisfactory record of daily water levels or discharge. Water levels obtained by the nonrecording devices described in these test methods can be used to calibrate recording water-level devices described in Test Methods B and C.

5.2 Devices included in these test methods are of two general types: those that are read directly, such as a staff gauge; and those that are read by measurement to the water surface from a fixed point, such as wire-weight, float-tape, electric-tape, point and hook gauges.

5.2.1 Staff, wire-weight, and chain gauges are commonly used as both outside auxiliary and reference gauges. Vertical- and inclined-staff, float-tape, electric-tape, hook and point gauges are commonly used as inside auxiliary and reference gauges.

5.3 Documentation of observations must be manually recorded.

**6. Apparatus**

6.1 *Staff Gauges:*

6.1.1 *Vertical Staff Gauges*—Staff gauges are usually graduated porcelain-enameled plates attached to wooden piers or pilings, bridge piers, or other hydraulic structures. They may also be installed on the inside of gauging station stilling wells as inside reference gauges. They are precisely graduated, usually to 0.02 ft or 2 mm, although other markings may be used for specific applications (see Fig. 1).

6.1.2 *Inclined Staff Gauges*—Inclined staff gauges usually consist of markings on heavy timbers, steel beams, or occasionally concrete beams built partially embedded into the natural streambed slope. Since they are essentially flush with the adjoining streambed, floating debris and ice are less likely

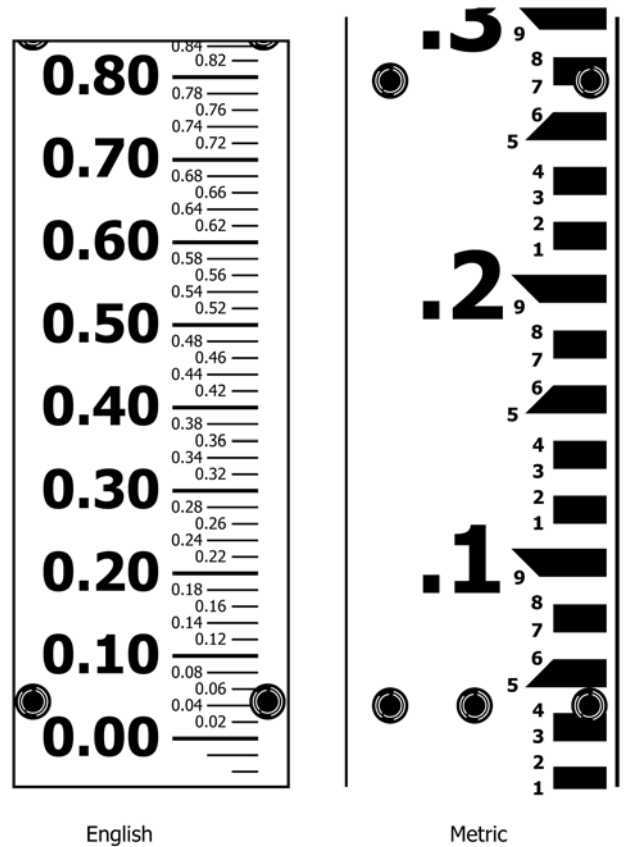

FIG. 1 Staff Gauges

to cause damage than for a vertical staff gauge. Individual graduation and marking of the installed gauges by engineering levels are required due to the variability of bank slope.

6.2 *Wire-Weight Gauge*—An instrument that is mounted on a bridge or other structure above a water body. Water levels are obtained by direct measurement of the distances between the device and the water surface. A wire-weight gauge consists of a drum wound with a single layer of cable, a bronze weight attached to the end of the cable, a graduated disk, a counter, and a check bar, all contained within a protective housing (see Fig. 2). The disk is graduated and is permanently connected to

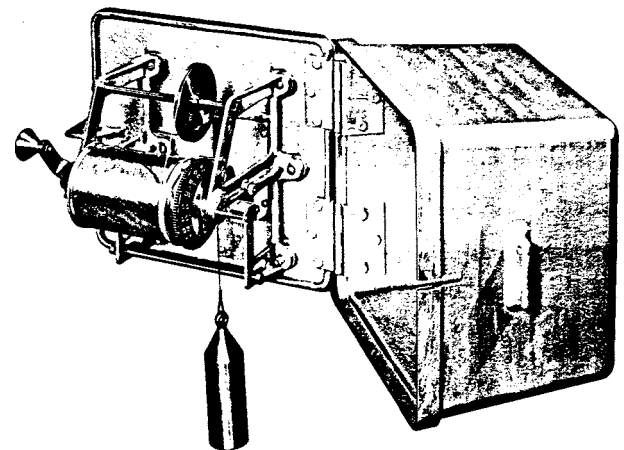

FIG. 2 Type A Wire-Weight Gauge

the counter and the shaft of the drum. The cable is guided to its position on the drum by a threading sheave. The reel is equipped with a pawl and ratchet for holding the weight at any desired elevation. A horizontally mounted check bar is mounted at the lower edge of the instrument. Differential levels are run to the check bar. When the weight is lowered to touch the check bar, readings of the counter are compared to its known elevation as a calibration procedure. The gauge is set so that when the bottom of the weight is at the water surface, the gauge height is indicated by the combined readings of the counter and the graduated disk.

6.3 *Needle Gauges*—Frequently referred to as point or hook gauges. A needle gauge consists of a vertically-mounted pointed metallic, small-diameter rod, which can be lowered until an exact contact is made with the water surface. A vernier or graduated scale is read to indicate a gauge height. A needle-type gauge offers high measurement accuracy, but requires some skill and good visibility (light conditions) in lowering and raising the device to a position where the point just pierces the water surface. These gauges are most commonly used in applications where the water surface is calm.

6.3.1 *Point Gauge*—A form of needle gauge where the tip or point approaches the water surface from above.

6.3.2 *Hook Gauge*—A form of needle gauge made in the shape of a hook, where the tip or point approaches the water surface from below (see Fig. 3). The hook gauge is easier to use in a stilling well application. As the point contacts the water surface, overhead light will reflect from a dimple on the water surface.

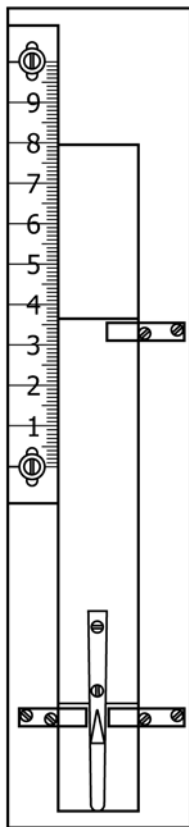

FIG. 3 Hook Gauge

6.4 *Float-Tape Gauge*—Consists of a float attached to a stainless steel graduated tape that passes over a suitable pulley with a counterweight to maintain tension. A pointer or other index is frequently fabricated as an integral part of the pulley assembly (see Fig. 4). Float-tape gauges frequently are combined with water-level recorders in a manner whereby the pulley is the stage drive wheel for the recorder.

6.5 *Electric-Tape Gauge*—Consists of a graduated steel tape and weight attached to a combined tape reel, voltmeter, datum index and electrical circuit, powered by a 4½ to 6 volt battery (see Fig. 5). The gauge frame is mounted on a shelf or bracket over the water surface, usually in a stilling well. The weight is lowered until the weight touches the water surface closing the electrical circuit that is indicated by the voltmeter. The gauge height is read on the tape at the index.

6.6 A reference point is frequently selected on a stable member of a bridge, stilling well, or other structure from which distance vertical measurements to the water surface are made by steel tape and weight. The reference point is a clearly defined location, frequently a file mark or paint mark to ensure that all readings are from the same location.

## 7. Calibration

7.1 Establish a datum. The datum may be a recognized datum such as National Geodetic Vertical Datum of 1929 (NGVD), a datum referenced to a recognized datum such as 580.00 ft NGVD 1929, a local datum, or an arbitrary datum. A datum is usually selected that will give readings of small positive numbers.

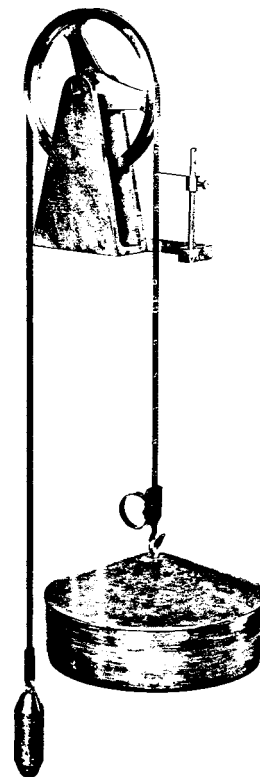

FIG. 4 Float-Type Gauge

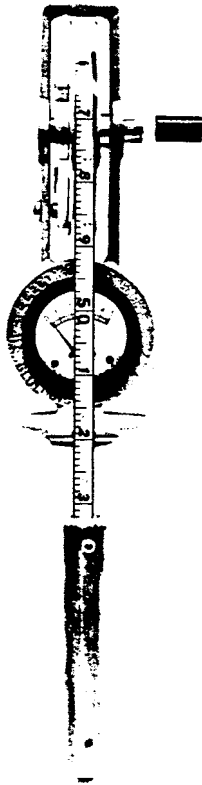

FIG. 5 Electric-Type Gauge

8.2 Gauges that require measurement from a fixed point to the water surface must follow procedures provided by manufacturers of the specific instrument.

8.3 Make a visual inspection of gauges at each reading to detect apparent damage, which could affect accuracy.

### TEST METHOD B—RECORDING WATER-LEVEL MEASUREMENT DEVICES

#### 9. Summary of Test Method

9.1 These test methods are applicable where continuous unattended records of water level or discharge are required. Procedures described in Test Method A are usually used to set these recording devices to the correct datum.

9.2 Devices, generically referred to as water-level recorders, or recorders, included in these test methods must be capable of recording stage and the time and date at which the stage occurred.

9.3 Recorders may sense water level by direct mechanical connection, usually by float-counterweight and tape or cable, by gas purge manometer systems (bubble gauges), or by electronic water level sensors (pressure transducer or acoustic devices).

9.4 Recorders may retain data in graphical, analog, digital, or other format.

9.5 Recorders are available that can remain unattended for periods from one week to longer than six months.

#### 10. Apparatus

##### 10.1 Types of Sensing Systems:

##### 10.1.1 Direct Reading Systems:

10.1.1.1 *Crest Stage Gauge*—A crest stage gauge is a simple sensing-recording device that is installed near a water body to record the highest water level that occurs between visits of field personnel. A wooden rod is encased in a steel or plastic pipe with holes for water to enter and rise to the outside water level. A recoverable high-water mark is left on the device by particles of ground cork that float to the highest water level (Fig. 6).

10.1.1.2 *Tape Gauge Maximum-Minimum Indicators*—These indicators include magnetic or mechanical accessories that record maximum or minimum travel of float-drive tape gauges or recorder-drive tapes.

##### 10.1.2 Mechanical Sensing Systems :

10.1.2.1 *Float Tape*—Consists of a float that floats on the water surface, usually in a stilling well, and a steel tape or cable which passes over a recorder drive pulley. A weight on the opposite end of the tape maintains tension in the tape or cable. The rise and fall of the water surface is thus directly transmitted to the recorder.

10.1.2.2 *Shaft Encoders*— These devices consist of a float-tape driven shaft and pulley assembly that converts the angular shaft position to an electronic signal compatible with electronic recorders. Analog output potentiometers and several digital format output encoding systems are available.

10.1.3 *Gas-Purge System*— This system is commonly known as a bubble gauge. A gas, usually nitrogen, is fed from a supply tank and pressure regulator through a tube and

7.2 Establish at least three reference marks (RMs). Reference marks must be located on independent permanent structures that have a good probability of surviving a major flood or other event that may destroy the gauge. Reference marks should be close enough to the water-level measuring device that the leveling circuit not require more than two or three instrument setups to complete elevation verification. If the NGVD datum is used, determine the elevation of the reference marks by differential leveling from the nearest NGVD benchmark.

7.3 Set the gauges to correct datum by differential leveling from the reference marks. Use leveling procedures described in a surveying text or “Levels at Streamflow Gauging Stations.”<sup>5</sup>

7.4 Run levels to gauges from RMs annually for the first 3 to 5 years, then if stability is evident, a level frequency of 3 to 5 years is acceptable. Rerun levels at any time that a gauge has been disturbed or has unresolved gauge reading inconsistencies. Run levels to all RMs, reference points, index points, and to each staff gauge, and to the water surface. Read the water surface at each gauge at the time levels are run. Document differences found and changes made in a permanent record.

#### 8. Procedure

8.1 Read direct reading gauges by observing the water surface on the gauge scale. Manually record this value on an appropriate form.

<sup>5</sup> Kennedy, E. J., “Levels at Streamflow Gauging Stations,” Techniques of Water Resources Investigations, Book 3, Chapter A-19, U.S. Geological Survey, 1990.

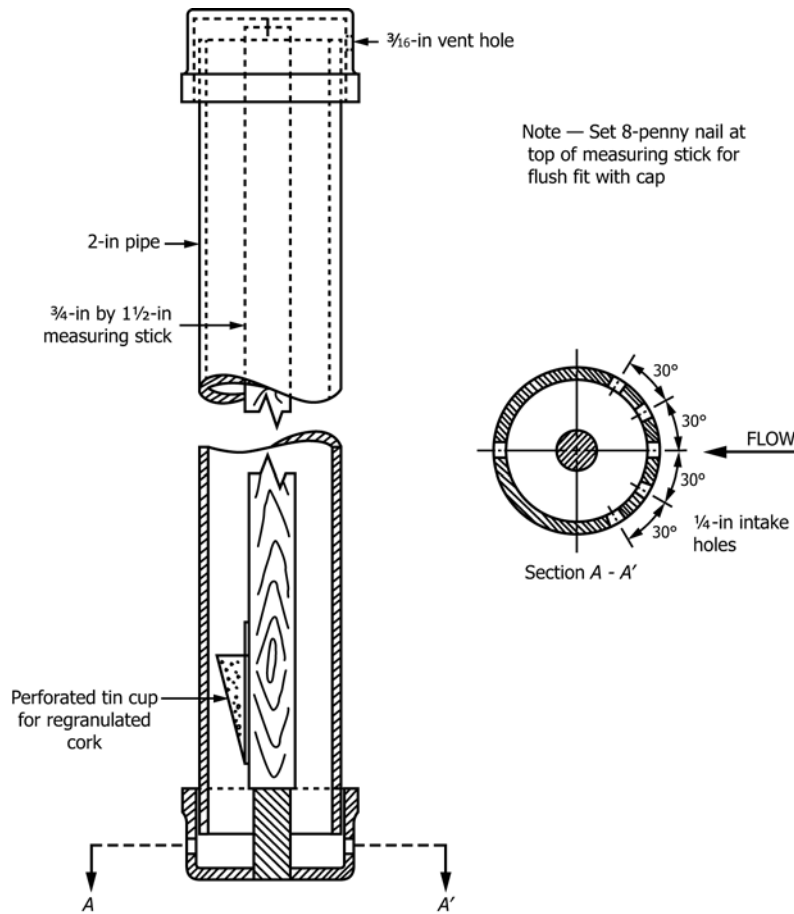

FIG. 6 Crest-Stage Gauge

bubbled freely into the water body through an orifice at a fixed location on or near the bottom of the water body. The gas pressure in the tube is equal to the piezometric head on the bubble orifice corresponding to the water level over the orifice. Several methods of sensing this line pressure and converting it to a recordable format are used (Fig. 7).

10.1.3.1 *Mercury Manometer*—The manometer assembly converts the gas purge line pressure to a shaft rotation for driving a recorder. Mercury is used because its specific gravity is 13.6 times that of water, and thus shortens the length of the

manometer. The theory and application of these devices are given in "Installation and Service Manual for U.S. Geological Survey Manometers."<sup>6</sup> These devices are being phased out of service because of potential damage to the environment should mercury spills occur.

<sup>6</sup> Craig, J. D., "Installation and Service Manual for U.S. Geological Survey Manometers," Techniques of Water Resources Investigations, Book 8, Chapter A-2, U.S. Geological Survey, 1983.

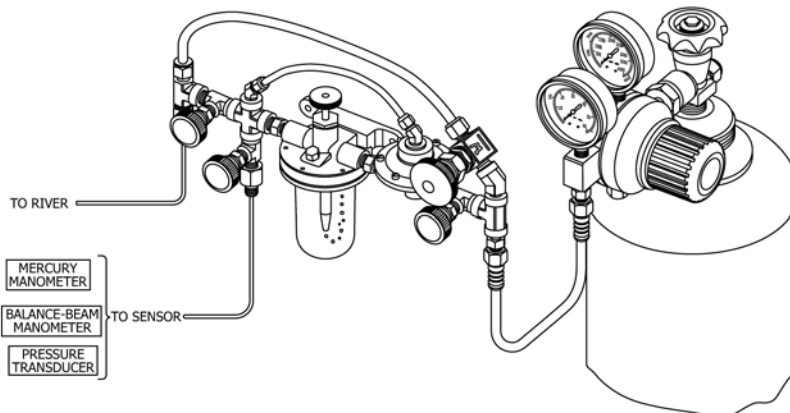

FIG. 7 Gas-Purge System



10.1.3.2 *Balance Beam Manometer*—This form of manometer employs a bellows system coupled with a balance beam and traveling weight. Pressure changes are transmitted to the bellows, which moves the balance beam. This movement causes the traveling weight on the balance beam to adjust to a new position to put the system back in balance. The change in position of the traveling weight corresponds to the change in water level over the orifice and is converted to a shaft rotation for recording.

10.1.3.3 *Nonsubmersible Pressure Transducer* —A pressure transducer converts gas-purge line pressure to gauge heights, and transmits this data in analog or serial digital format to a compatible electronic recorder.

10.1.4 *Electronic Sensing Systems :*

10.1.4.1 *Submersible Pressure Transducer* —A pressure transducer is attached below the surface at a known datum elevation of the water body, and measures the distance above the transducer and transmits this data in analog or serial digital format by electrical cable to a compatible electronic recorder.

10.1.4.2 *Downward-Looking Acoustic Transducers* —These devices are mounted above the water surface at a fixed datum and measure the distance to the water surface by measuring the elapsed time of the reflected acoustic signal off the water surface. The data is transmitted in analog or serial digital format by electrical cable to a compatible electronic recorder.

10.1.4.3 *Upward-Looking Acoustic Transducers* —These devices are mounted on or near the bed of a water body, and measure the distance to the water surface with an acoustic signal. This data is transmitted in analog or serial digital format by electrical cable to a compatible electronic recorder.

10.2 *Recorders:*

10.2.1 *Graphic Recorders*—These recorders are also known as analog and strip-chart recorders (Fig. 8). Many designs of these devices have been used for many years. Most have a weight- or spring-driven clock or an ac or 12-volt battery-powered electric clock to move a paper chart at known speed. A mechanical float-tape or manometer unit moves a pen or pencil up and down over the chart in response to the water body level fluctuations. These units provide a constant recording of time and stage, are easy to manually observe changes in stage, but are not easily amenable to fully automated data processing, however, semi-automated processing is possible through digitization of the pen trace.

10.2.2 *Digital Recorders*—This system is a battery- or ac-powered slow-speed paper-tape punch that records a 4-digit number on a 16-channel paper tape at preset time intervals of 1, 5, 6, 15, 30, or 60 min. The stage input is a shaft rotation from the float-tape or manometer drive. The unit was developed in the early 1960's as a means of automating data processing (Fig. 9).

10.2.3 *Electronic Recorders*—A number of battery-powered electronic recorders are presently commercially available that are suitable for the field collection of hydrologic data. They range from inexpensive single-channel to complex sensor- and sampler-controlling multichannel configurations. Many types require an electronic retriever or laptop computer to retrieve stored data and transport it to an office computer for data processing, or connection to a remote interrogation device

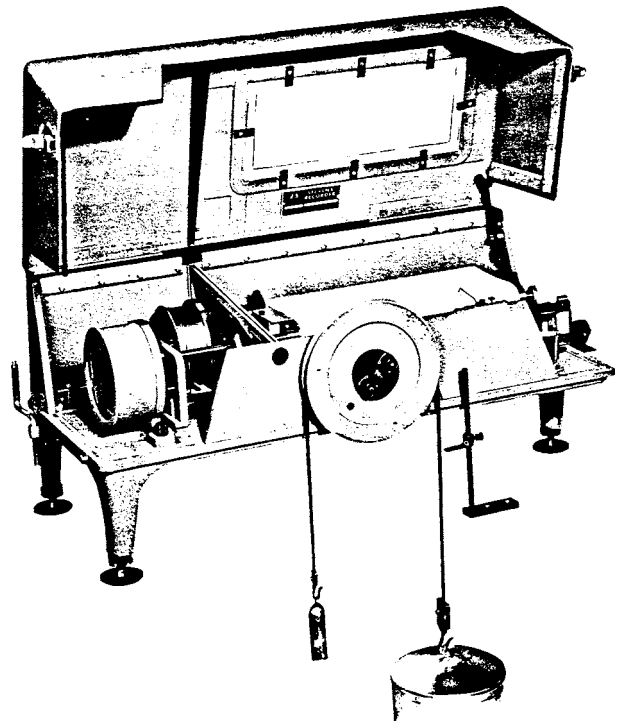

FIG. 8 Graphic Recorder

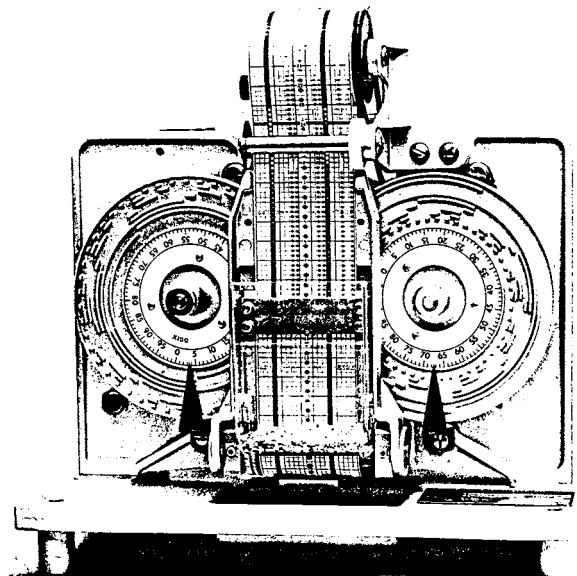

FIG. 9 Digital Recorder

(Test Method C). Several manufacturers offer units with removable memory devices that can be carried easily back to an office retrieval-computer interface to facilitate data transfer from field locations.

11. Calibration

11.1 Mechanical sensors and recorders generally do not require pre-installation calibration. Field calibration requires setting time and gauge height recording units to observations made on nonrecording gauges (see Section 8).

11.2 Electronic sensors and recorders may require pre-installation laboratory calibrations such as deadweight testing of pressure transducers. Preassembly of electronic components prior to field installation is recommended to verify operational compatibility. Follow manufacturers' or users' quality-assurance procedures.

## 12. Procedure

12.1 Install unit at field site following installation instructions.

12.2 Set gauge height to nonrecording gauges (see Section 8) and time and date with a suitable time reference.

12.3 Retrieval of record and required maintenance at end of unattended period as follows:

12.3.1 Observe and record gauge height from nonrecording gauge and correct time and date for record verifications and possible adjustment.

12.3.2 Remove data record following manufacturer's or user's instructions, or both.

12.3.3 Observe condition of sensors, recorder, and associated equipment, wind clock or replace battery, as applicable.

12.3.4 Reset gauge-height datum if necessary, set time and date, and restart recorder (see Section 12.3.1).

## TEST METHOD C—REMOTE INTERROGATION WATER-LEVEL MEASUREMENT DEVICES

### 13. Summary of Test Method

13.1 These test methods are applicable where remote interrogation of water level or discharge is required. Procedures described in Test Method A are generally used to set these devices to the correct datum. Devices described in this section may be accessories to devices described in Test Method B.

13.2 Remote interrogation devices may be nonrecording, or may be able to store and then transmit data collected over a period of time.

13.3 Remote interrogation may be by telephone, direct wire, satellite, radio, or meteorburst transmission, as described in Section 14.

13.4 Information on transmission or receiving equipment and procedures it not included in the test method.

### 14. Apparatus

14.1 *Telephone Interrogation Systems*—Systems that transmit water levels over standard telephone lines in either signals audible to the human ear or in coded digital or pulse format are commercially available.

14.1.1 *Audible Transmission Systems*—A telephone call from any regular telephone to a telephone at the instrument triggers the devices to transmit a series of beeps to indicate the instantaneous water level in audible hearing range or voice synthesizers that can report in words and numbers, "the stage is 10.50 feet." The operable stage range is usually from 00.00 to 99.99 ft. The advantage of this system is that any phone can be used to interrogate the system, making this device particularly useful during flood events, when many users can obtain data from multiple locations (Fig. 10).

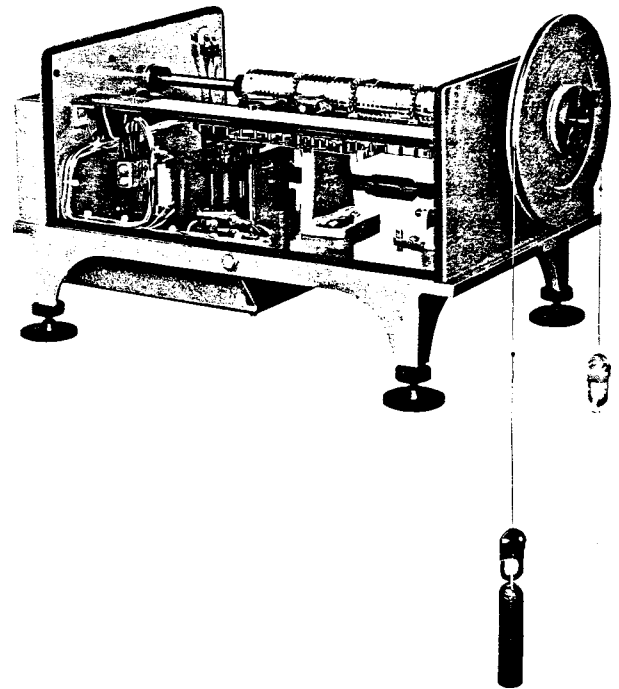

FIG. 10 Telemark Gauge

14.1.2 *Coded Digital Devices*—These devices transmit instantaneous water levels in high-speed serial ASCII format over regular phone lines to a remote computer or other decoding device. These devices may either be stand-alone sensing units or as attachments to other recording devices, frequently digital-punch tape or electronic recorders.

14.2 *Direct Wire Systems*—This type of equipment consists of a sensing-transmitting unit at the water-level sensing location which is connected by electrical cable to a receiving unit that typically drives a recorder or other readout device. Common applications are short distances such as headwater and tailwater elevations at a dam to an operating house. Maximum distance for practical application would be about 15 miles.

14.2.1 *Position Motor Systems*—This system consists of a pair of self-synchronizing motors, one driven by a mechanical sensing system such as a float-tape system that serves as a transmitting unit, and a second whose rotor follows the rotary motions of the transmitter that drives a recorder or other indicating device.

14.2.2 *Impulse System*—An impulse-sending device sends incremental electrical signals over the connecting lines to a receiving device that provides a rotational output to operate a mechanical recorder or directly to an electronic recording device. This system can operate over dedicated phone lines over longer distances than a position motor system.

14.3 *Satellite Telemetry*—Satellite telemetry systems transfer data from water and sensing devices to remote field office locations via a geostationary operational environmental satellite (GOES). A water level sensor (see Section 10) is connected to a GOES transmitter, usually known as a data collection platform (DCP). The GOES transmitter, actually a radio transmitting at 401 to 402 MHz, transfers the water level in

binary form to the GOES satellite, which retransmits the data to a direct readout ground station (DRGS). The DRGS receives, reformats the data in engineering units, and stores it in a computer for distribution or additional processing. Authorization and allocation of satellite channels must be obtained from the National Oceanic and Atmospheric Administration, National Environmental Satellite Data and Information Services. Most DCP's require a plug-compatible program unit, often a laptop computer to program and initialize the unit.

14.4 *Radio Transmission Systems* —In this type of system, data from a water-level sensor is transmitted via a line-of-sight radio transmitter to a receiving and processing device at a field office location. Repeater stations are required for long distances or mountainous terrain. Power requirements for the on-site transmission require commercial electric service or solar battery-charger systems.

14.5 *Meteor-Burst Transmission Systems* —Meteor-burst telemetry uses ionized meteor trails as reflectors for VHF radio signals to overcome the line-of-sight limitations of standard VHF radio and microwave communications. Billions of meteors enter the earth's atmosphere daily, burning up and leaving an ionized trail of gasses that remain for periods of a few microseconds to a few seconds. The altitude of useful trails is 80 to 120 km above the earth's surface, which limits the range of communications to about 2,000 km. There are also diurnal and seasonal variations in meteor trail density that can affect transmission reliability.

14.5.1 A meteor-burst system is composed of one or more master stations and a number of remote sites. Remote sites are microprocessor controlled data collection and transmission stations that collect data at preselected time intervals, for example, every 15 min, and process and store these data for transmission to the master station one or more times per day. To retrieve data from a remote site, the master station continuously transmits until a meteor trail occurs at the correct location to reflect the signal to the remote site. Upon receiving the master station signal, the remote site immediately transmits its data using the same meteor trail. Remote sites can also be programmed to initiate communications to the master station when selected sensor output exceeds a specified threshold.

14.5.2 Advantages of meteor-burst technology include access to data in near real time, relatively low system costs, operation on a common radio frequency, and communication security due to the random nature of the meteor trail.

14.5.3 Limitations are related to the short duration of meteor trails that limit the message length, and the diurnal and seasonal variation in the density of meteor trails.

## 15. Calibration

15.1 Remote interrogation water-level transmission devices do not usually require precalibration prior to field installation; however, connect all system components tested as a system prior to installation in remote field sites.

15.2 For field calibration, set stage and time outputs to observations of the base nonrecording gauge (see Section 8).

## 16. Procedure

16.1 Install system at field site, following manufacturer's or other applicable instructions. This may require specialized programming devices for certain electronically based units.

16.2 Prior to leaving field site, verify that data transmissions are being received at remote-interrogation location.

16.3 At subsequent station visits, verify that proper gauge height, time, and possible additional parameters are correctly reported. Use procedures described in Section 15.

## 17. Precision and Bias

17.1 Determination of the precision and bias for these test methods is not possible, at either the multiple or single operator level, due to the high degree of instability of water surfaces of open-channel flow. Temporal and spatial variability of the boundary and flow conditions do not allow for a consent standard to be used for representative sampling. Any estimate of errors would be misleading to users.

17.2 In accordance with paragraph 1.6 of Practice [D2777](#), an exception to the precision and bias statement required by [D2777](#) was recommended by the results advisor and concurred with by the Technical Operations Section of the Committee D19 Executive Subcommittee on June 24, 1992.

17.3 The accuracy of a water-level measurement is directly related to the following.

17.3.1 Errors are caused by the instability of structures supporting the gauge-sensing device. Staff gauges mounted on bridge structures or piers are subject to being damaged or moved by floating debris, ice, being bumped by boats, as well as deterioration of supporting fixtures. Gauges mounted in stilling wells may be subject to instability of these structures, siltation of intake pipes connecting to the water body, and manufacturing, installation, or calibration errors.

17.3.2 Errors caused by inadequate leveling procedures in establishing and checking datum.

17.3.3 In direct reading devices, observational errors include ripple or wave effect of the water surface, distance from observer to gauge, cleanliness and color contrast of the gauge, angle of observation, light conditions, and observer's eyesight, including the use or non-use of binoculars or other visual aids. In contact gauges, this includes the ripple or wave effect of the water surface, wind effect on measuring devices, distance to water surface from gauge platforms, light conditions, and observer's eyesight.

17.3.4 Recording gauges are subject to mechanical errors such as gear lash, chain sprocket lash, temperature or mechanical dimensional changes, leaking floats, mechanical tolerance caused by lack of lubrication, or infiltration of dust or dirt, and numerous other mechanical problems. Additional errors in stilling well data are caused by the changing position of the float and counterweight, the amount of submerged float in the water, especially after the counterweight submerges at high stages, and errors or stage lags in intake pipes connecting the stilling well to the water body.



17.3.5 Electronic devices are subject to recording errors caused by power surges, electromagnetic interference, electronic component drift, and other problems that can affect data display, transmission, and recording.

17.3.6 When water-level measuring devices are installed in gauging stations or other hydraulic structures using stilling wells and intakes, intake errors are possible. The intake pipe should be large enough for the water in the well to follow the rise and fall of stage without significant delay, but still dampen wave fluctuations. The following relationship may be used to calculate the lag for an intake pipe for a given rate of change of stage.

$$\Delta h = \frac{0.01}{g} \frac{L}{D} \left( \frac{A_w}{A_p} \right)^2 \left( \frac{dh}{dt} \right)^2$$

where:

$\Delta h$  = lag, ft (m),

$g$  = acceleration of gravity, ft/s/s (m/s/s),  
 $L$  = intake length, ft (m),  
 $D$  = intake diameter, ft (m),  
 $A_w$  = area of stilling well, ft<sup>2</sup> (m<sup>2</sup>),  
 $A_p$  = area of intake pipe, ft<sup>2</sup> (m<sup>2</sup>), and  
 $dh/dt$  = rate of change of stage, ft/s (m/s).

17.3.7 Water levels in open channels are read and recorded to the nearest 0.01 ft (2 mm). Visual observations in rough-surfaced water bodies may require estimation of the highs and lows of water-surface profiles to estimate mean stage. Readings taken in stilling wells are more accurate because the smaller-diameter intake pipes provide a dampening effect, if properly installed.

## 18. Keywords

18.1 elevation; gauges; stage; water-level recorders; water-level sensors

*ASTM International takes no position respecting the validity of any patent rights asserted in connection with any item mentioned in this standard. Users of this standard are expressly advised that determination of the validity of any such patent rights, and the risk of infringement of such rights, are entirely their own responsibility.*

*This standard is subject to revision at any time by the responsible technical committee and must be reviewed every five years and if not revised, either reapproved or withdrawn. Your comments are invited either for revision of this standard or for additional standards and should be addressed to ASTM International Headquarters. Your comments will receive careful consideration at a meeting of the responsible technical committee, which you may attend. If you feel that your comments have not received a fair hearing you should make your views known to the ASTM Committee on Standards, at the address shown below.*

*This standard is copyrighted by ASTM International, 100 Barr Harbor Drive, PO Box C700, West Conshohocken, PA 19428-2959, United States. Individual reprints (single or multiple copies) of this standard may be obtained by contacting ASTM at the above address or at 610-832-9585 (phone), 610-832-9555 (fax), or service@astm.org (e-mail); or through the ASTM website (www.astm.org). Permission rights to photocopy the standard may also be secured from the Copyright Clearance Center, 222 Rosewood Drive, Danvers, MA 01923, Tel: (978) 646-2600; http://www.copyright.com/*