



# Standard Test Method for Measurement of Hexane Extractable Content of Polyolefins<sup>1</sup>

This standard is issued under the fixed designation D5227; the number immediately following the designation indicates the year of original adoption or, in the case of revision, the year of last revision. A number in parentheses indicates the year of last reappraisal. A superscript epsilon ( $\epsilon$ ) indicates an editorial change since the last revision or reappraisal.

## 1. Scope\*

1.1 This test method describes an extraction/gravimetric procedure for determination of the amount of hexane soluble low molecular weight material present in polyethylene, polypropylene, ethylene-propylene copolymers, and ethylene-vinyl acetate copolymers. This test method is a modification of the Food and Drug Administration (FDA) procedure for determining hexane extractables of polyolefins. This test method is based upon the presumption that the weight of the residue extract present in the solvent is equal to the amount extracted from the film sample and could therefore be quantified by measuring the weight loss of the extracted film, eliminating the complex and time-consuming evaporation process described in 21 CFR 177.1520.

1.2 *This standard does not purport to address all of the safety concerns, if any, associated with its use. It is the responsibility of the user of this standard to establish appropriate safety and health practices and determine the applicability of regulatory limitations prior to use.*

1.3 *The values stated in SI units are to be regarded as the standard.* Units used in 21 CFR 177.1520 are also used in this test method. Units are in conformance with Federal Code 21 CFR 177.1520, from which this test method is derived.

NOTE 1—There is no known ISO equivalent to this standard.

## 2. Referenced Documents

2.1 *ASTM Standards:*<sup>2</sup>

D883 Terminology Relating to Plastics

D1239 Test Method for Resistance of Plastic Films to Extraction by Chemicals

D1600 Terminology for Abbreviated Terms Relating to Plastics

E131 Terminology Relating to Molecular Spectroscopy

E691 Practice for Conducting an Interlaboratory Study to

<sup>1</sup> This test method is under the jurisdiction of ASTM Committee D20 on Plastics and is the direct responsibility of Subcommittee D20.70 on Analytical Methods.

Current edition approved June 1, 2013. Published July 2013. Originally approved in 1992. Last previous edition approved in 2008 as D5227 - 01(2008)<sup>\epsilon</sup>1. DOI: 10.1520/D5227-13.

<sup>2</sup> For referenced ASTM standards, visit the ASTM website, www.astm.org, or contact ASTM Customer Service at service@astm.org. For *Annual Book of ASTM Standards* volume information, refer to the standard's Document Summary page on the ASTM website.

Determine the Precision of a Test Method

2.2 *Federal Document.*<sup>3</sup>

21 CFR 177.1520

## 3. Terminology

3.1 The definitions given in Terminology D883, D1600, and E131 are applicable to this test method.

3.2 *Abbreviations:*

3.2.1 EVA—ethylene-vinyl acetate copolymer.

3.2.2 LDPE—low-density polyethylene.

3.2.3 HDPE—high-density polyethylene.

3.2.4 LLDPE—linear low-density polyethylene.

3.2.5 FDA—Food and Drug Administration.

3.2.6 PP—polypropylene.

## 4. Summary of Test Method

4.1 Film samples are extracted with hexane for 2 h at  $49.5 \pm 0.5^\circ\text{C}$ , dried, and weighed.

4.2 The loss in weight of the film is presumed to be equal to the extractable content determined by solvent evaporation in the FDA protocol.

## 5. Significance and Use

5.1 FDA requirements for maximum extractables are specified for resin and uses. This test method provides a means to determine the amount of hexane-soluble low molecular weight material present in polyolefins. It is applicable to resins containing greater than 0.20 % extractables.

## 6. Apparatus

6.1 *Water Bath*, maintained at  $49.5 \pm 0.5^\circ\text{C}$ .

6.2 *Resin Kettle*, 1500-mL.

6.3 *Kettle Head*, 3-neck, with one 45/50 and two 24/40 female joints, and appropriate stoppers.

6.4 *Clamp*.

6.5 *Allihn Condenser*, Size C, with 45/50 male joint.

<sup>3</sup> Available from Standardization Documents Order Desk, DODSSP, Bldg. 4, Section D, 700 Robbins Ave., Philadelphia, PA 19111-5098, http://www.dodssp.daps.mil.

\*A Summary of Changes section appears at the end of this standard

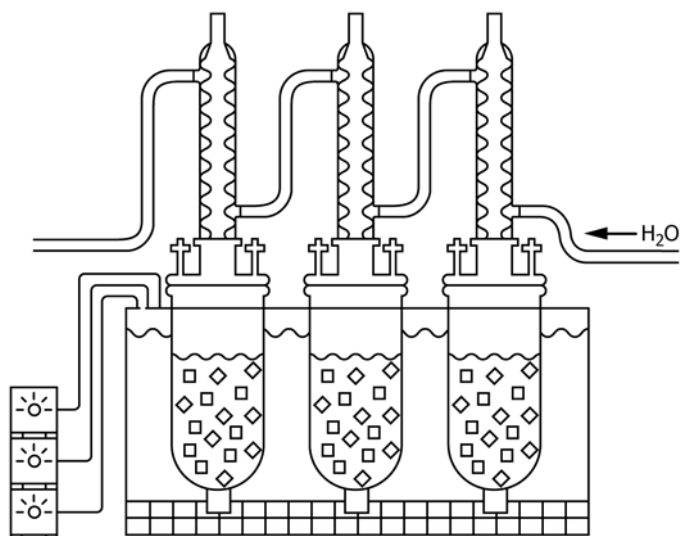

FIG. 1 Resin Kettle Setup

6.6 *Plastic Sleeves*, tetrafluoroethylene (TFE), to fit Allihn condenser 45/50 male joint.

6.7 *Vacuum Oven*, capable of maintaining  $80 \pm 5^\circ\text{C}$  and a minimum of 25-in. Hg pressure.

6.8 *Magnetic Stirring Bar*, egg-shaped, TFE-coated,  $1\frac{1}{2}$  by  $\frac{5}{8}$  in.

6.9 *Submersible Magnetic Stirring Motor*, with power supply.

6.10 *Analytical Balance*, capable of weighing to 0.1 mg.

## 7. Reagents and Materials

7.1 *n-Hexane*, aromatic free ( $<1$  mg/L), minimum 85 % *n*-Hexane-reagent grade or equivalent. The solvent must be free of aromatic compounds that would significantly increase the solubility of the resin. The solvent grade specified represents the minimum required purity.

## 8. Materials

8.1 *Blown Film*, compression molded films, or cast films are suitable for testing.

8.2 *Film*, approximately 2.5 g, with a thickness not exceeding 4 mil is required for a single determination.

## 9. Procedure

9.1 Assemble the resin kettle setup with glass stopper, clamp, and magnetic stirring bar. (See Fig. 1.)

9.2 Add 1000 mL of *n*-Hexane to the kettle assembly.

9.3 Stopper the kettle and clamp the assembly into the water bath set at  $49.5 \pm 0.5^\circ\text{C}$ .

NOTE 2—Temperature is a critical factor in this analysis and must not vary more than  $1^\circ\text{C}$ . If the temperature exceeds these limits, the test must be discontinued and restarted. The FDA protocol also states the temperature of the contents must be brought to  $49.5 \pm 0.5^\circ\text{C}$  within 20 to 25 min.

NOTE 3—The level of water in the bath must be kept at least 2 cm above the level of the solvent in the kettle to ensure the temperature equilibrium. Position the kettle so that the center bottle of the kettle is sitting on a submersible stirrer. Start stirring and allow the hexane to heat for 1 h.

9.4 Using gloves and metal tweezers to avoid sample contamination, cut 2.7 g of the prepared film sample (4 mil or less in thickness) into 1-in. squares using clean sharp scissors.

NOTE 4—Care must be exercised when cutting the samples to avoid ragged edges on the specimen. Small shards of film or contamination present at initial weighing can easily be lost during the test, adversely affecting the test results.

9.5 Weigh  $2.5 \pm 0.05$  g of film squares and record the initial film weight to the nearest 0.1 mg. Also record the number of film pieces.

NOTE 5—Forty or more squares will be obtained depending on the film thickness. Some laboratories have found that a basket assembly, as shown in Appendix X1, eliminates the need to count the film pieces before and after the solvent extraction step.

9.6 Add the film sample to the hexane making sure all squares become immersed in the solvent. (Use tweezers.) Replace the kettle head with condenser column. Extract for 2 h.

9.7 After the extraction period:

9.7.1 Filter the contents of the resin kettle through the fritted porcelain funnel.

9.7.2 Transfer the film squares, using tweezers, to a 200-mL Berzelius beaker and recount the film pieces to verify that none were lost during transfer.

9.7.3 Cover the beaker with a watchglass and place it in a vacuum oven at  $80 \pm 5^\circ\text{C}$  for 2 h.

9.7.4 After 2 h, remove the covered beaker from the vacuum oven and place it in a desiccator to cool to room temperature (estimated 1 h).

9.8 Remove the film squares using tweezers and weigh them to the nearest 0.1 mg.

9.9 Repeat 9.7.3 and 9.7.4 until a constant weight is obtained.

## 10. Calculation

10.1 Calculate the weight percent of extractables present in the original sample as follows:

$$\text{hexane extractables, \%} = \frac{(A - B) \times 100 \times 0.935}{A} \quad (1)$$

where:

*A* = weight of original sample film, g,  
*B* = weight of the film after extraction, g, and  
 0.935 = correlation factor to eliminate the bias between the original FDA technique and this alternate test method.

## 11. Report

11.1 Report the hexane extractables to the nearest 0.01 % as calculated in 10.1.

## 12. Precision and Bias<sup>4</sup>

12.1 *Hexane Extractable Content of Polyolefins:*

12.1.1 Table 1 is based on a round robin conducted in 1990 in accordance with Practice E691, involving five materials

<sup>4</sup> Supporting data are available from ASTM Headquarters. Request RR:D20-1173.

**TABLE 1 Hexane Extractable Content of Polyolefins, Weight**

Material	Average	<i>Sr</i>	<i>SR</i>	<i>r</i>	<i>R</i>
HDPE	0.26	0.03	0.05	0.09	0.15
LLDPE	0.88	0.11	0.16	0.31	0.46
LDPE	1.74	0.08	0.15	0.21	0.42
EVA	3.54	0.28	0.33	0.78	0.93
PP	3.80	0.29	0.35	0.81	0.98

tested by ten laboratories. The materials were supplied by one laboratory. Each test result was an individual determination. Each laboratory obtained six test results for each of the five materials. Each laboratory obtained two test results for each material tested each day for three days.

NOTE 6—**Caution:** The following explanations of *r* and *R* (12.1.2 – 12.1.2.3) are only intended to present a meaningful way of considering the approximate precision of this test method. The data in Table 1 should not be rigorously applied to acceptance or rejection of material, as those data are specific to the round robin and may not be representative of other lots, conditions, materials, or laboratories. Users of this test method should apply the principles outlined in Practice E691 to generate data specific to their laboratory and materials, or between specific laboratories. The principles of 12.1.2 – 12.1.2.3 would then be valid for such data.

12.1.2 *Concept of r and R*—If *Sr* and *SR* have been calculated from a large enough body of data, and for test results that were averages from testing five specimens.

12.1.2.1 *Repeatability Limit, r*—(Comparing two test results for the same material, obtained by the same operator using the same equipment on the same day.) The two test results should be judged not equivalent if they differ by more than the *r* value for that material.

12.1.2.2 *Reproducibility Limit, R*—(Comparing two test results for the same material, obtained by different operators using different equipment in different laboratories.) The two test results should be judged not equivalent if they differ by more than the *R* value for that material.

12.1.2.3 Any judgment in accordance with 12.1.2.1 or 12.1.2.2 would have an approximate 95 % (0.95) probability of being correct.

12.1.3 *Bias*—There are no recognized standards by which to estimate bias of this test method.

### 13. Keywords

13.1 ethylene-propylene copolymers; ethylene-vinyl acetate copolymers; extractables; FDA; hexane; plastics; polyethylene; solvent extraction

## APPENDIX

### (Nonmandatory Information)

#### X1. BASKET ASSEMBLY FOR *n*-HEXANE EXTRACTABLES

X1.1 If one uses the basket assembly shown in Fig. X1.1, the following steps should be performed after the 2-h hexane extraction (9.6) Also, the sample and basket must be weighed together and recorded before starting the extraction:

X1.1.1 Rinse the basket and contents by immersing several times in fresh *n*-hexane contained in a small beaker, allowing the basket to drain between rinsings.

X1.1.2 Remove the excess solvent by briefly blowing the basket with a stream of nitrogen or dry air.

X1.1.3 Place the basket in a vacuum oven for 2 h at 80±5°C, then cool to ambient temperature in a desiccator (estimated 1 h).

X1.1.4 Reweigh the basket and its contents to the nearest 0.1 mg.

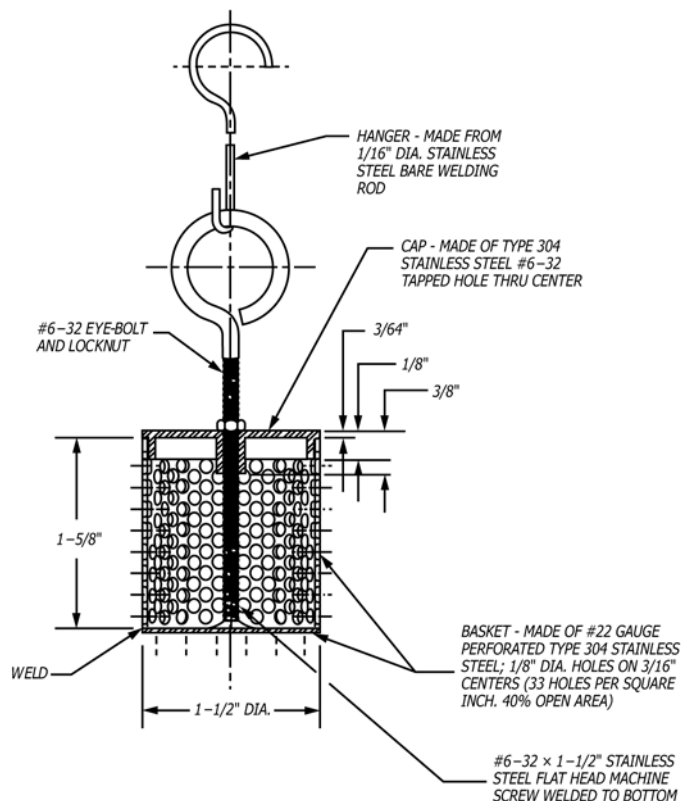

FIG. X1.1 Basket for *n*-Hexane Extractables<sup>1</sup>

## SUMMARY OF CHANGES

Committee D20 has identified the location of selected changes to this standard since the last issue (D5227 – 01(2008)<sup>e1</sup>) that may impact the use of this standard. (June 1, 2013)

- (1) Removed permissive language.
- (2) Removed materials manufacturers information.
- (3) Revised X1.1.

*ASTM International takes no position respecting the validity of any patent rights asserted in connection with any item mentioned in this standard. Users of this standard are expressly advised that determination of the validity of any such patent rights, and the risk of infringement of such rights, are entirely their own responsibility.*

*This standard is subject to revision at any time by the responsible technical committee and must be reviewed every five years and if not revised, either reapproved or withdrawn. Your comments are invited either for revision of this standard or for additional standards and should be addressed to ASTM International Headquarters. Your comments will receive careful consideration at a meeting of the responsible technical committee, which you may attend. If you feel that your comments have not received a fair hearing you should make your views known to the ASTM Committee on Standards, at the address shown below.*

*This standard is copyrighted by ASTM International, 100 Barr Harbor Drive, PO Box C700, West Conshohocken, PA 19428-2959, United States. Individual reprints (single or multiple copies) of this standard may be obtained by contacting ASTM at the above address or at 610-832-9585 (phone), 610-832-9555 (fax), or service@astm.org (e-mail); or through the ASTM website (www.astm.org). Permission rights to photocopy the standard may also be secured from the Copyright Clearance Center, 222 Rosewood Drive, Danvers, MA 01923, Tel: (978) 646-2600; http://www.copyright.com/*