



# Standard Test Method for Evaluating the Scuffing Load Capacity of Oils (FZG Visual Method)<sup>1</sup>

This standard is issued under the fixed designation D5182; the number immediately following the designation indicates the year of original adoption or, in the case of revision, the year of last revision. A number in parentheses indicates the year of last reapproval. A superscript epsilon ( $\epsilon$ ) indicates an editorial change since the last revision or reapproval.

## 1. Scope

1.1 This test method, the Forschungstelle für Zähräder und Getriebebau (Research Site for Gears and Transmissions) Visual Method, commonly referred to as the FZG Visual Method, is intended to measure the scuffing load capacity of oils used to lubricate hardened steel gears. Scoring, a form of abrasive wear, is also included as a failure criteria in this test method. It is primarily used to assess the resistance to scuffing of mild additive treated oils such as industrial gear oils, transmission fluids, and hydraulic fluids. High EP type oils, for example, those oils meeting the requirements of API GL-4 and GL-5, generally exceed the capacity of the test rig and, therefore, cannot be differentiated with this test method.

1.2 The values stated in SI units are to be regarded as standard. No other units of measurement are included in this standard.

1.3 *This standard does not purport to address all of the safety concerns, if any, associated with its use. It is the responsibility of the user of this standard to establish appropriate safety and health practices and determine the applicability of regulatory limitations prior to use.* For specific safety information, see Section 7, Section 8, 9.2, 9.3.1, and Annex A1.

## 2. Referenced Documents

### 2.1 ASTM Standards:<sup>2</sup>

- D235 Specification for Mineral Spirits (Petroleum Spirits) (Hydrocarbon Dry Cleaning Solvent)
- G40 Terminology Relating to Wear and Erosion

<sup>1</sup> This test method is under the jurisdiction of ASTM Committee D02 on Petroleum Products, Liquid Fuels, and Lubricants and is the direct responsibility of Subcommittee D02.L0.11 on Tribological Properties of Industrial Fluids and Lubricates.

Current edition approved Jan. 1, 2014. Published February 2014. Originally approved in 1991. Last previous edition approved in 2008 as D5182–97(2008). DOI: 10.1520/D5182-97R14.

<sup>2</sup> For referenced ASTM standards, visit the ASTM website, [www.astm.org](http://www.astm.org), or contact ASTM Customer Service at [service@astm.org](mailto:service@astm.org). For *Annual Book of ASTM Standards* volume information, refer to the standard's Document Summary page on the ASTM website.

### 2.2 DIN Standard:<sup>3</sup>

DIN 51 354 Teil 1 FZG Zahnrad Verspannungs Prüfmaschine—Allgemeine Arbeitsgrundlagen

## 3. Terminology

### 3.1 Definitions:

3.1.1 See also Terminology G40.

3.1.2 *abrasive wear*—wear due to hard particles or hard protuberances forced against and moving along a solid surface.

3.1.3 *adhesive wear (scuffing)*—wear due to localized bonding between contacting solid surfaces leading to material transfer between the two surfaces or loss from either surface.

3.1.4 *scoring*—a severe form of wear characterized by the formation of extensive grooves and scratches in the direction of sliding.

3.1.5 *scratches*—the result of mechanical removal or displacement, or both, of material from a surface by the action of abrasive particles or protuberances sliding across the surfaces.

### 3.2 Definitions of Terms Specific to This Standard:

3.2.1 *polishing*—a mild form of abrasive wear resulting in minor loss of material and typically characterized by a smooth finish and removal of all or part of the initial grinding marks.

## 4. Summary of Test Method

4.1 An FZG Gear Test Machine is operated at constant speed (1450 rpm) for a fixed period (21700 revolutions—approximately 15 min) at successively increasing loads until the failure criteria is reached; the initial oil temperature is 90°C beginning at load stage four (see Table 1). The test gears are examined initially and after the prescribed duration at each load stage for cumulative damage (scuffing) to the gear tooth flanks.

## 5. Significance and Use

5.1 The transmission of power in many automotive and industrial applications is accomplished through the use of geared systems. At higher operating speeds it is well known

<sup>3</sup> Available from Beuth Verlag GmbH (DIN-- DIN Deutsches Institut für Normung e.V.), Burggrafenstrasse 6, 10787, Berlin, Germany.

TABLE 1 Standard Load Stages for FZG Scuffing Test

Load Stage	Torque on Pinion (N·m)	Tooth Normal Force (N)	Hertzian Contact Pressure (N/mm <sup>2</sup> )	Total Work Transmitted (kW·h)	Load Clutch Loaded with <sup>A</sup>
1	3.3	99	146	0.19	H1
2	13.7	407	295	0.97	H2
3	35.3	1044	474	2.96	H2+K
4	60.8	1799	621	6.43	H2+K+W1
5	94.1	2786	773	11.8	H2+K+W1+W2
6	135.5	4007	929	19.5	H2+...+W3
7	183.4	5435	1080	29.9	H2+...+W4
8	239.3	7080	1232	43.5	H2+...+W5
9	302.0	8949	1386	60.8	H2+...+W6
10	372.6	11029	1539	82.0	H2+...+W7
11	450.1	13342	1691	107.0	H2+...+W8
12	534.5	15826	1841	138.1	H2+...+W9

<sup>A</sup> where:  
H1 = load lever H1 (light),  
H2 = load lever H2 (heavy),  
K = support rod for weights, and  
W1 to W9 = weights for loading (supplied with test rig).

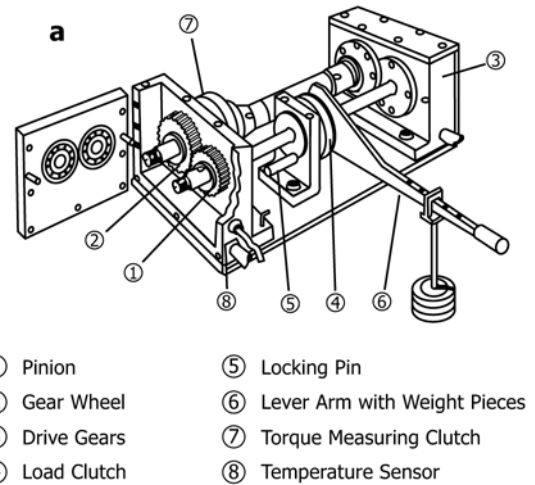

A. Diagram of a Typical FZG Test Rig

that the lubricant/additive system can be a significant factor in preventing scuffing (adhesive wear) damage to gears. This test method is used to screen the scuffing load capacity of oils used to lubricate spur and helical (parallel axis) gear units.

5.2 The test method is limited by the capabilities of the equipment (test rig and gears), and the performance observed may not directly relate to scuffing performance observed with spiral bevel on hypoid gearing. It is also limited to discriminating between oils with mild EP additives or less. Lubricants containing higher levels of additives, that is, those meeting the requirements of API GL4 or GL5, generally exceed the maximum load capacity of the test rig and, therefore, cannot be distinguished for their scuffing capabilities by this test method.

6. Apparatus

6.1 FZG Gear Test Rig:

6.1.1 A more complete description of the test rig and operating instructions may be found in the instruction manuals available from the manufacturers/suppliers identified in A2.1.2.

6.1.2 The FZG gear test rig utilizes a recirculating power loop principle, also known as a four-square configuration, to provide a fixed torque (load) to a pair of precision test gears. A schematic of the test rig is shown in Fig. 1A and Fig. 1B. The drive gearbox and the test gearbox are connected through two torsional shafts. Shaft 1 contains a load coupling used to apply the torque through the use of known weights hung on the loading arm.

6.1.3 The test gearbox contains heating and cooling elements to maintain and control the temperature of the oil. A temperature sensor located in the side of the test gearbox is used to control the heating/cooling system as required by the test operating conditions.

6.1.4 The test rig is driven by an electric motor capable of delivering at least 5.5 kW at 1440 rpm.

6.2 Test Gears—The test gearset (pinion and gear) are commonly referred to as type A profile and conform to the

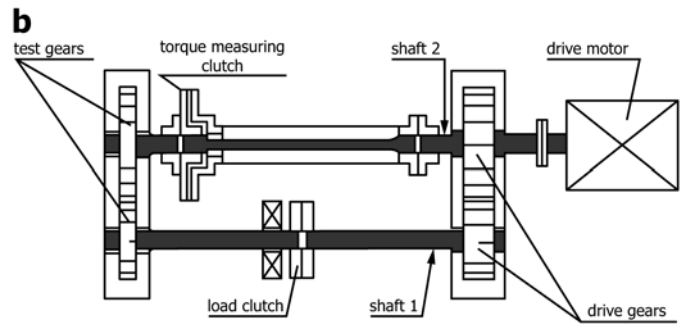

B. Schematic Section of an FZG Test Rig

FIG. 1 FZG Test Rig

information supplied in Table 2. A schematic of the profile is shown in Fig. 2. Both sides of the test gear flanks can be used for testing purposes since only one side is loaded during the evaluation. It should be noted that these gears have been

TABLE 2 Detail Data for the “A” Profile Gears

Parameter	Value	Units
Center Distance	91.5	mm
Effective Tooth Width	20.0	mm
Pitch Circle Diameter:		
Pinion	73.2	mm
Gear	109.8	mm
Tip Diameter:		
Pinion	88.7	mm
Gear	112.5	mm
Module	4.5	mm
Number of Teeth:		
Pinion	16	
Gear	24	
Profile Modification		
Pinion/Gear	0.8635/–0.5103	
Pressure Angle		
Normal/Working	20/22.5	degrees
Hardness		
Rockwell C	60 to 62	
Surface Roughness		
Ra	0.3 to 0.7	µm

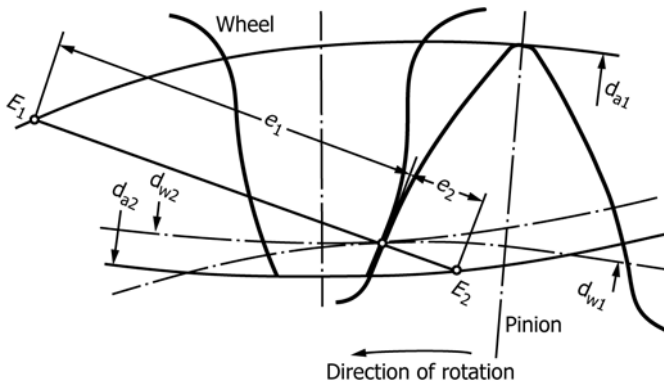

FIG. 2 Schematic of A Profile Test Gears

designed with a large profile modification which increases their sensitivity to adhesive wear modes of failure.

6.3 *Timer Mechanism*—A suitable timer or revolution counter must be used to control the number of revolutions during each load stage of the test. The timer should be capable of shutting down the test rig at the appropriate time.

6.4 *Hot Plate*—A hot plate or suitable heating device is required to warm the gears to 60 to 80°C for assembly on to the shafts.

## 7. Reagents and Materials

7.1 *Mineral Spirits (Stoddard Solvent)*. (**Warning**—Combustible. Vapor harmful. Keep away from heat, sparks, and open flame (see Annex A1.1). Type I conforming to the requirements outlined in Specification D235.)

## 8. Hazards

8.1 (**Warning**—This test method involves the use of highly loaded gears and shafts turning at high speeds. Appropriate precautions must be taken to protect personnel (see Annex A1.2).)

## 9. Preparation of Apparatus

9.1 *Test Gears*—The test gears are cleaned with Stoddard solvent to remove all of the protective coating. In some cases this requires brushing (soft bristle brush) of the gears to remove excess amounts of the coating material. Each gear is to be dried and then visually inspected for any evidence of damage or corrosion on the tooth flank surfaces. In such cases where damage or corrosion is found these gears should not be used for test purposes.

9.2 *Test Gearbox*—The test gearbox and bearings shall be washed thoroughly with Stoddard solvent to remove the previous test oil. (This can be done at the termination of a test after the oil has been drained from the gearbox and prior to disassembling the test gears.) It is recommended that the gearbox be flushed twice with Stoddard solvent to remove all traces of the previous test oil. After draining the solvent from the test gearbox the unit should be air dried to remove all traces of solvent. (**Warning**—Be sure the gearbox temperature has decreased below 60°C prior to adding the Stoddard solvent.)

9.3 *Assembly of Test Gears*—The test gears, spacers, and bearings are heated on a hot plate or other device to approximately 60 to 80°C. Install the test gears on the shafts with the alignment marks in the position shown in Fig. 3. Complete the assembly of the gearbox with the appropriate spacers, bearings, and front cover.

9.3.1 It has been found critical for correct results that the test gears are properly aligned on their respective shafts. (**Warning**—Misalignment can lead to erratic or lower fail loads due to uneven distribution of the load on the tooth.)

9.4 *Test Oil*—Add 1.25 L of test oil to the test gearbox (approximately to the centerline of the shafts).

9.5 *Final Assembly*—Secure the top of the test gear case in place with the 6 bolts. Connect the heater to its power source.

## 10. Procedure

10.1 Prior to starting a test apply load stage 12 to the system for 2 to 3 min without running the motor (Table 1). This is done to ensure all clearances are in the correct working position. Remove all weights before proceeding to 10.2.

10.2 With the test gears mounted, load clutch locking pin in place, and load clutch bolts loose, apply load stage 1 (see Table 1) to the loading clutch. Tighten the bolts of the load clutch, (the load clutch bolts should be tightened in a star or crosswise pattern to a torque of 100 Nm) remove the weight assembly and lever arm, and remove the load clutch arresting bolt. Start the motor (1450 rpm) and turn on the heaters. Run for 15 min (21700 revolutions), then stop motor.

10.3 Insert the locking pin and loosen the load clutch bolts so that the load is removed from the shafts. Apply load stage 2 according to Table 1. Tighten the bolts of the load clutch, (the load clutch bolts should be tightened in a star or crosswise pattern to a torque of 100 Nm) remove the weights and lever arm, and remove the load clutch locking pin. Start the motor (1450 rpm) and turn on the heaters. After 15 min (21700 revolutions) stop the motor. Repeat this sequence for load stage 3.

10.4 Beginning with load stage 4, and all subsequent load stages, the procedure is the same as outlined in 10.2 except that the oil temperature must be between 90 and 93°C prior to starting the motor.

10.4.1 At the end of load stage 4 and each subsequent load stage, record the final temperature and inspect the pinion gear for damage without removing the gears from the gearbox.

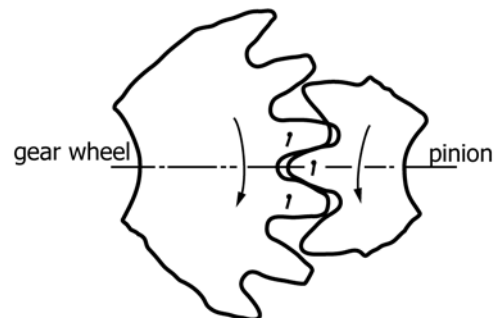

FIG. 3 Marking and Mounting of Test Gears

Record the type and amount of damage observed on the gear flank in accordance with the terminology described in Section 3 and from the examples shown in Fig. 4. The inspection is carried out without the aid of magnification. It is recommended that an inspection sheet such as that shown in Fig. 5 be used to record the damage observed after each load stage.

10.4.2 The failure criteria is reached when the summed total width of scuffing (adhesive wear) or scoring damage from all 16 teeth is estimated to equal or exceed one gear tooth width, that is, 20 mm. This is then reported as the failure load stage. Examples of acceptable and unacceptable distress levels are shown in Annex A3.

10.5 The test is continued until the failure load stage is reached. If the failure criteria has not been met after completing load stage 12, the test is terminated at that time.

**11. Report**

11.1 Report the failure load stage according to the criteria outlined in 10.4.2. If the criteria was not met at the end of load stage 12 then report the failure load stage as greater than 12.

STAGE	FZG SCUFFING (in mm.) TOOTH															
	1	2	3	4	5	6	7	8	9	10	11	12	13	14	15	16
1																
2																
3																
4																
5																
6																
7																
8																
9																
10																
11																
12																

FIG. 5 Sample Inspection Sheet

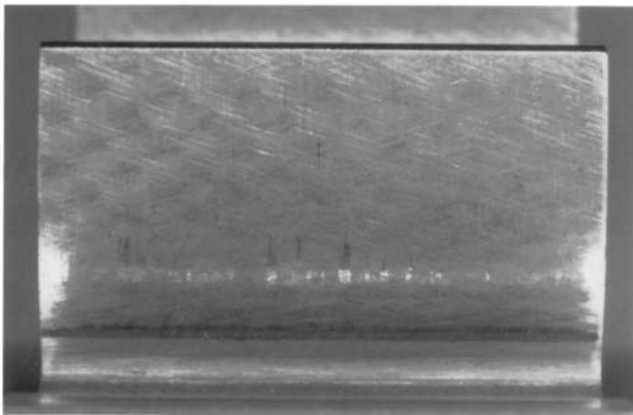

**Polishing**

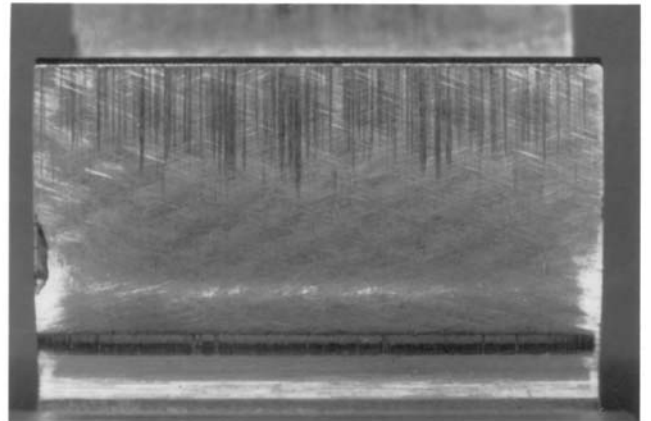

**Scoring**

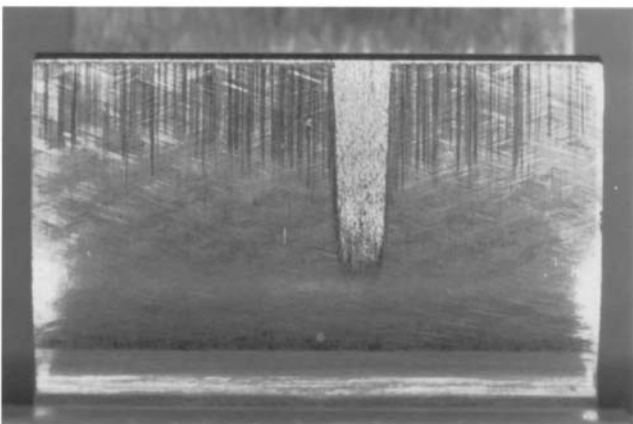

**Scoring and Scuffing**

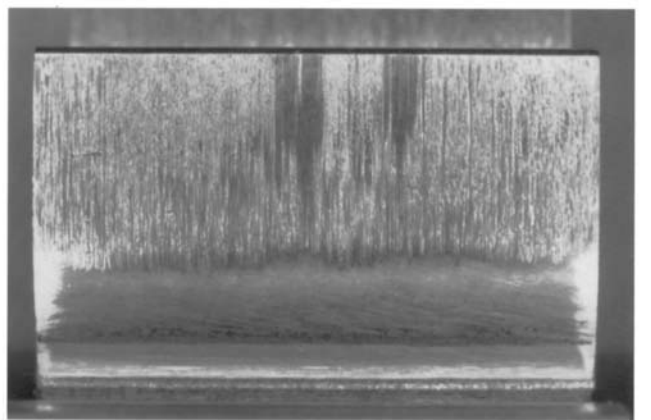

**Scuffing**

FIG. 4 Examples of Gear Distress in the FZG Test



## 12. Precision and Bias

12.1 *Precision*—The precision of this test method as determined by the statistical examination of the interlaboratory test results is as follows:

12.1.1 *Repeatability*—The difference between successive results obtained by the same operator with the same apparatus under constant operating conditions on identical test materials would, in the long run, in the normal and correct operation of the test method exceed the following value in only one case in twenty.

Repeatability = 2

12.1.2 *Reproducibility*—The difference between two single and independent results obtained by different operators work-

ing in different laboratories on identical material would in the long run exceed the following values only in one case in twenty.

Reproducibility = 2

NOTE 1—The values in the statements were determined in a cooperative program conducted by the FZG Study Group and reported at the June 1989 meeting of L0.11.10 of Committee D02.

12.2 *Bias*—Since there is no accepted reference material suitable for determining the bias for the procedure in this test method, bias has not been determined.

## 13. Keywords

13.1 E.P. oils; extreme pressure; FZG; gear oil; gear scuffing; hydraulic fluids; spur gear; transmission fluids

## ANNEXES

### (Mandatory Information)

#### A1. WARNING STATEMENTS

##### A1.1 Mineral Spirits Solvent

- A1.1.1 **Caution**—Combustible.  
Vapor harmful.  
Keep away from heat, sparks and open flame.  
Keep container closed.  
Use with adequate ventilation.  
Avoid breathing vapor or mist.  
Avoid prolonged or repeated contact with skin.

##### A1.2 General Precautions

- A1.2.1 *Personal Injury Hazard* —Machinery guards are supplied with the FZG test machine to protect personnel from hazards associated with rotating machinery. These guards must be properly installed before operating the equipment.
- A1.2.2 *Electrical Hazard*—The electrical connections for the drive motor and heater must be of approved design and construction.

#### A2. TEST EQUIPMENT

##### A2.1 FZG Test Machine

A2.1.1 *Description*— The FZG test machine is described in detail in DIN 51 354 Teil 1.

A2.1.2 *Ordering Information*—The FZG test machine as described in DIN 51 354 Teil 1 can be ordered from the following sources:

- A2.1.2.1 Strama Maschinenbau GmbH, Ittlinger Str. 195 D-94315 Straubing, Germany.
- A2.1.2.2 Falex Corp., 1020 Airpark Dr., Sugar Grove, IL 60554.

##### A2.2 Test Gears

A2.2.1 *Ordering Information*—The “A” profile test gears can be ordered from the following sources:

A2.2.1.1 Strama Maschinenbau, GmbH, Ittlinger Str 195, D-94315 Straubing, Germany.

A2.2.1.2 Falex Corporation, 1020 Airpark Dr., Sugar Grove, IL 60554.

##### A2.3 Supplemental Information

A2.3.1 *Manuals*—Operation manuals for the test rig may be obtained from the manufacturers/suppliers identified in [A2.1.2](#).

A2.3.2 For additional information regarding the test rig or gear design and spare parts, one can contact Technische Universität München, Forschungstelle für Zahnräder und Getriebbau, Boltzmannstr. 15, 85748 Garching, Federal Republic of Germany.

A3. GEAR DISTRESS

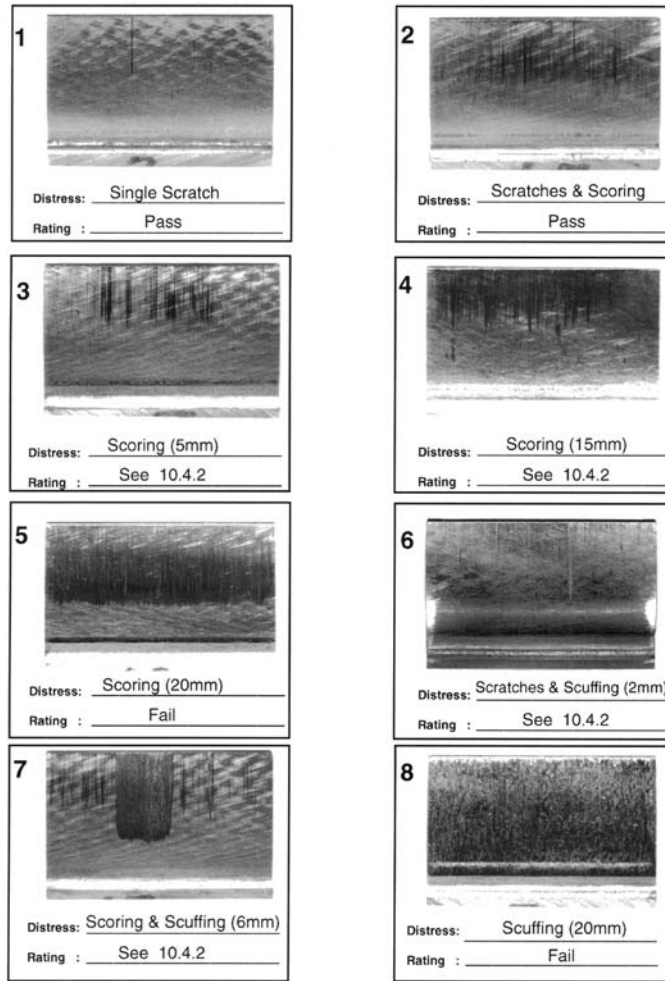

NOTE 1—Numbers in parentheses indicate approximate width of damaged/distressed area.  
**FIG. A3.1 Examples of FZG Gear Distress**

A3.1 Fig. A3.1 provides examples of FZG gear distress.

*ASTM International takes no position respecting the validity of any patent rights asserted in connection with any item mentioned in this standard. Users of this standard are expressly advised that determination of the validity of any such patent rights, and the risk of infringement of such rights, are entirely their own responsibility.*

*This standard is subject to revision at any time by the responsible technical committee and must be reviewed every five years and if not revised, either reapproved or withdrawn. Your comments are invited either for revision of this standard or for additional standards and should be addressed to ASTM International Headquarters. Your comments will receive careful consideration at a meeting of the responsible technical committee, which you may attend. If you feel that your comments have not received a fair hearing you should make your views known to the ASTM Committee on Standards, at the address shown below.*

*This standard is copyrighted by ASTM International, 100 Barr Harbor Drive, PO Box C700, West Conshohocken, PA 19428-2959, United States. Individual reprints (single or multiple copies) of this standard may be obtained by contacting ASTM at the above address or at 610-832-9585 (phone), 610-832-9555 (fax), or [service@astm.org](mailto:service@astm.org) (e-mail); or through the ASTM website ([www.astm.org](http://www.astm.org)). Permission rights to photocopy the standard may also be secured from the Copyright Clearance Center, 222 Rosewood Drive, Danvers, MA 01923, Tel: (978) 646-2600; <http://www.copyright.com/>*