



Standard Test Method for Shear Strength (Dynamic Method) of Hook and Loop Touch Fasteners¹

This standard is issued under the fixed designation D5169; the number immediately following the designation indicates the year of original adoption or, in the case of revision, the year of last revision. A number in parentheses indicates the year of last reapproval. A superscript epsilon (ϵ) indicates an editorial change since the last revision or reapproval.

1. Scope

1.1 This test method measures the shear strength of hook and loop touch (CRE) fasteners using a recording constant rate of extension tensile testing machine.

1.2 The values stated in inch-pound units are to be regarded as standard. The values given in parentheses are mathematical conversions to SI units that are provided for information only and are not considered standard.

1.3 *This standard does not purport to address all of the safety concerns, if any, associated with its use. It is the responsibility of the user of this standard to establish appropriate safety and health practices and determine the applicability of regulatory limitations prior to use.*

2. Referenced Documents

2.1 *ASTM Standards:*²

- D76 Specification for Tensile Testing Machines for Textiles
- D123 Terminology Relating to Textiles
- D618 Practice for Conditioning Plastics for Testing

3. Terminology

3.1 *Definitions:*

3.1.1 *hook and loop fastener*—a touch fastener, comprised of two flexible mating strips, the surface of one mating strip being covered with tiny, stiff protrusions shaped like hooks which engage the other mating strip which is covered with pliable loops.

3.1.1.1 *Discussion*—This fastener comprises a non-adhesive method of joining two materials where ready adjustment and removal is desirable and fastening is accomplished by pressing the mating strips together and separation is accomplished by simply peeling apart. Terms herein referring to hook and loop fastening systems shall be construed to include other types of

touch fasteners in which the fastening strength in the shear mode (that is, against forces applied in the plane of the fastener) substantially exceeds the fastening strength in the peel mode (that is, against forces applied perpendicular to the planes of the two components of the fastener).

3.1.2 *shear strength, n*—the resistance to forces that cause, or tend to cause, two contiguous parts of a body to slide relatively to each other in a direction parallel to their plane of contact.

3.2 For definitions of other textile terms used in this test method, refer to Terminology D123.

4. Summary of Test Method

4.1 An area of hook surface is applied to an area of loop surface with controlled engagement pressure. This combination is subjected to a dynamic shear force acting parallel to the surfaces of the specimens.

5. Significance and Use

5.1 This test method gives a measure of a key property of hook and loop touch fasteners which is of interest to users of such devices. This is a means of determining the resistance to separation when forces are applied parallel to the plane of the fastener.

5.2 In the case of a dispute arising from differences in reported test results when using this test method for acceptance testing of commercial shipments, the purchaser and the supplier should conduct comparative tests to determine if there is a statistical bias between their laboratories. Competent statistical assistance is recommended for the investigation of bias. As a minimum, the two parties should take a group of test specimens which are as homogenous as possible and which are from a lot of hook and loop of the type in question. The test specimens should then be randomly assigned in equal numbers to each laboratory for testing. The average results from the two laboratories should be compared using Student's t-test and an acceptable probability level chosen by the two parties before the testing began. If a bias is found, either its cause must be found and corrected or the purchaser and the supplier must agree to interpret future test results in the light of the known bias.

¹ This test method is under the jurisdiction of ASTM Committee D13 on Textiles and is the direct responsibility of Subcommittee D13.54 on Subassemblies.

Current edition approved Feb. 1, 2015. Published April 2015. Originally approved in 1991. Last previous edition approved in 2010 as D5169 – 98(2010). DOI: 10.1520/D5169-98R15.

² For referenced ASTM standards, visit the ASTM website, www.astm.org, or contact ASTM Customer Service at service@astm.org. For *Annual Book of ASTM Standards* volume information, refer to the standard's Document Summary page on the ASTM website.

6. Apparatus

6.1 *Roller*—consisting of a smooth steel surface, approximately 4¾ in. (21 mm) in diameter, 2¼ in. (57 mm) wide, and equipped with a handle, length 4⅞ in. (105 mm), for propelling the roller back and forth without adding additional weight to the specimen being rolled (see Fig. 1). The weight of the roller (including the handle) is 11 lbs. ± ¼ lb (4994 ± 114 g).

6.2 *Testing Machine*—A constant rate of extension (CRE) tensile tester shall be used. The tester shall have two clamps with centers in the same plane, parallel to the direction of the motion of the stressing clamp, and so aligned that they will hold the specimen ends wholly in the same plane; a means of moving the stressing clamp at a uniform rate of 12.0 ± 0.5 in./min (305 ± 13 mm/min); an autographic device for recording the maximum load.

6.2.1 The instrument shall be calibrated to an accuracy of 1.0 % of the full scale and the scale range used for the test shall be such that the main test falls within 20 to 80 % of full range.

7. Sampling

7.1 Select the test samples so as to be as representative of the unit (a shipment, a lot, and so forth.) as possible.

7.2 *Lot*—A lot shall consist of all the material of the same type, color and width, made at the same time from the same materials in no more than a two week period. It shall be expressed in linear units of 10 000 yards (9144 m).

7.3 *Sample Rolls*—Select one roll randomly from each linear unit 10 000 yards (9144 m). If the lot does not contain five units, additional rolls shall be selected from the lot to give a sample size of five rolls.

7.4 For specification purposes, the material under test must be mated with material supplied by the manufacturer of the material being tested.

8. Specimen Preparation

8.1 Hook and loop material for this test shall be in the width as supplied, not to exceed 1 in. (25.4 mm) in width. For materials greater than 1 in. (25.4 mm), the material shall be slit to 1 in. (25.4 mm) in width. If material is less than 1 in. (25.4 mm) wide as tested, test results will not be directly proportional to those obtained with the 1 in. (25.4 mm) wide material.

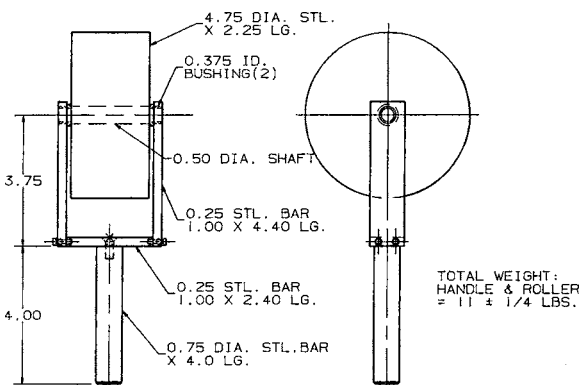

FIG. 1 Roller for Making Closure of Hook and Loop Touch Fasteners Prior to Testing

8.1.1 Remove the outer lap of each roll before selecting the required number of strips, hook and loop, 4 in. ± ¼ in. (102 ± 6 mm) long.

8.1.2 Each specimen is marked with an arrow (↑) pointing in the direction that the specimen is unwound from the roll. This arrow is marked on the specimen on the leading end as it is unwound from the roll. The arrow (↑) indicates the direction of the hooks and loops of the specimens.

8.1.3 Select the sample consisting of the four (4) contiguous specimens as described in 8.1.1 and mark it with the appropriate identification (roll number, lot number, date, and so forth). There are four (4) possible direction configurations of closure as shown in Fig. 2. The four specimens of hook and loop selected will be used to characterize the shear strength of each of the configurations.

9. Conditioning

9.1 Condition the specimens in an atmosphere for testing of 23 ± 2°C (73.4°F ± 3.6°F) and 50 ± 5 % relative humidity as described in Practice D618 for a period of 24 h or until the specimens reach moisture equilibrium. Lay specimens flat with the functional side up so that the conditioning atmosphere has free access to them.

10. Procedure

10.1 Select from the four (4) specimens of hook and loop, the first closure to be tested and referring to Fig. 2, prepare the first closure specimen with the marked arrows as shown in Sequence 1.

NOTE 1—The reason for testing all four possible closure configurations is that the hook or loop material, or both, may have directionality (that is, the hooks or loops may not be perpendicular to the base fabric of which they are a component), and affect the shear force.

10.1.1 Carefully align and superimpose the hook strip over the loop strip so that the hook strip covers the loop strip and the marked ends are matched as shown in Fig. 2, Sequence 1.

10.1.2 Place a flat steel plate 8 in. (20 cm) long and 1½ in. (4 cm) wide and weighing 4 pounds (1814 gm) (approximately equivalent to ½ lbs per in.² of closure) onto the closure, completely covering it, slowly, and without adding any hand

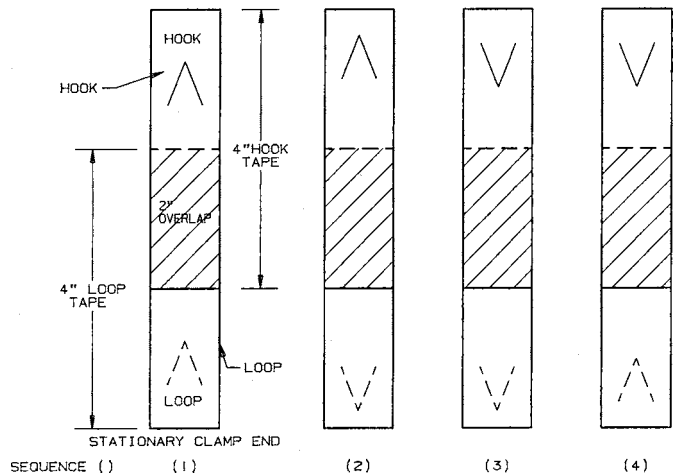

FIG. 2 Test Configurations for Dynamic Shear Strength of Hook and Loop Fasteners (Not to Scale)

pressure. After 2 s remove the plate. This initial mating of the closure is done to create just enough hook and loop engagement so as to be able to continue with the test procedure.

10.1.3 Securely fasten the two ends of the mated hook and loop to a hard flat surface such as a metal plate, table top, and so forth using masking tape, staples, clamps, hook and loop straps, or the like.

10.1.4 Push the roller without adding weight over the entire length of the joined strips and then pull it back over the entire length. This constitutes one cycle; a continuous uninterrupted back and forth motion of the roller, without lifting it from the material. Each cycle should take about 2 s.

10.1.4.1 Perform five (5) cycles with the roller without lifting it from the material. Remove the specimen from the holder.

10.2 Prepare the second closure specimen as described in 10.1.1 – 10.1.4.1 except with the marked ends as shown in Sequence 2 of Fig. 2.

10.3 Prepare the third closure specimen as described in 10.1.1 – 10.1.4.1 except with the marked ends as shown in Sequence 3 of Fig. 2.

10.4 Prepare the fourth closure specimen as described in 10.1.1 – 10.1.4.1 except with the marked ends as shown in Sequence 4 of Fig. 2.

10.5 In the sequence in which the closure specimens were prepared, select them for testing in the tensile tester.

10.6 Position the clamps of the tensile tester so they are $3 \pm \frac{1}{8}$ in. (76 ± 3 mm) apart. Place the free ends of the specimen to be tested in the clamps of the tester with the hook strip in the moving clamp. The mated specimen should be approximately centered and aligned approximately perpendicular to the clamps. Use a clamp separation speed of $12.0 \pm \frac{1}{2}$ in./min (305 ± 12 mm/min).

10.7 Observe the chart paper produced by the autographic recorder. Make note on the recording chart of the test specimen number and the sequence number from diagram 2.

10.8 Record the force (maximum load) required to separate the hook and loop closure.

11. Calculation

11.1 Convert the force (maximum load) to separate the 2 in. overlap of closure to lb per in.² (α psi).

11.2 Calculate the average force (maximum load) of the sample from the four (4) specimens tested.

12. Report

12.1 Report the following information:

12.1.1 State that the specimens were tested as directed in ASTM Test Method D5169.

12.1.2 Describe the material or product sampled (including type, color, source and manufacturer's code or part number),

12.1.3 The width of the material tested and whether the width was as supplied or slit down to 1 in. (25.4 mm) as required in 8.1,

12.1.4 The shear strength as the average separation force (maximum load) of each sample in lbs per in.² to the nearest lb per in.² (psi).

13. Precision and Bias

13.1 *Precision*—Based on limited testing from one laboratory, the within-laboratory or repeatability standard deviation is about 2.51 lb or the coefficient of variation is about 0.07. Repeatability is dependent on the specific material being tested: some materials would be expected to be higher or lower than this. Between-laboratory reproducibility is being determined by the subcommittee.

13.2 *Bias*—The procedure in Test Method D5169 for measuring the shear strength of hook and loop touch fasteners has no bias because the value of the shear strength of hook and loop touch fasteners can be determined only in terms of a test method.

14. Keywords

14.1 fastener; hook; hook and loop; loop; shear; shear strength; touch fastener

ASTM International takes no position respecting the validity of any patent rights asserted in connection with any item mentioned in this standard. Users of this standard are expressly advised that determination of the validity of any such patent rights, and the risk of infringement of such rights, are entirely their own responsibility.

This standard is subject to revision at any time by the responsible technical committee and must be reviewed every five years and if not revised, either reapproved or withdrawn. Your comments are invited either for revision of this standard or for additional standards and should be addressed to ASTM International Headquarters. Your comments will receive careful consideration at a meeting of the responsible technical committee, which you may attend. If you feel that your comments have not received a fair hearing you should make your views known to the ASTM Committee on Standards, at the address shown below.

This standard is copyrighted by ASTM International, 100 Barr Harbor Drive, PO Box C700, West Conshohocken, PA 19428-2959, United States. Individual reprints (single or multiple copies) of this standard may be obtained by contacting ASTM at the above address or at 610-832-9585 (phone), 610-832-9555 (fax), or service@astm.org (e-mail); or through the ASTM website (www.astm.org). Permission rights to photocopy the standard may also be secured from the Copyright Clearance Center, 222 Rosewood Drive, Danvers, MA 01923, Tel: (978) 646-2600; http://www.copyright.com/