

Standard Terminology of Seams and Seam Finishes Used in Home Sewing¹

This standard is issued under the fixed designation D 4965; the number immediately following the designation indicates the year of original adoption or, in the case of revision, the year of last revision. A number in parentheses indicates the year of last reapproval. A superscript epsilon (ϵ) indicates an editorial change since the last revision or reapproval.

1. Scope

1.1 This terminology provides a uniform, easily understood language for the definitions and descriptions of seams and seam finishes used in home sewing.

1.1.1 These seams and seam finishes may be produced on a conventional sewing machine or by hand.

1.1.2 These terms and definitions are not necessarily applicable to the apparel manufacturing industry.

1.2 This terminology provides a common base for use in the preparation of educational materials and pattern guide sheets for home sewing.

1.3 Other seam types or finishes may be more appropriate if equipment other than the conventional sewing machine is available.

1.4 For other terms associated with textiles, refer to Terminology D 123.

2. Referenced Documents

2.1 *ASTM Standards:*

D 123 Terminology Relating to Textile Materials²

D 1353 Terminology of Basic Sewing Machine Stitches²

3. Terminology

3.1 *Definitions:*

back side, *n*—in textile materials, the side of the material that faces innermost in the completed product. (Ant. **face side, right side**. Syn. *wrong side*.)

bound seam-finish, *n*—in home sewing, a seam finish in which another material is used to enclose the cut edges of one or more seam allowances. (Compare **Hong Kong seam finish**.) (See Fig. 1.)

DISCUSSION—A bound seam-finish is made by (1) enclosing the cut seam allowance edge(s) in another fabric and (2) machine stitching through all thicknesses close to the edge of the binding. Material used may be strips of lightweight bias-cut woven fabric or lightweight knit fabric such as tricot or net. If tape or binding is used, the wider fold side of the tape or binding is positioned underneath the seam allowance. Usually each seam allowance edge is enclosed individually; however,

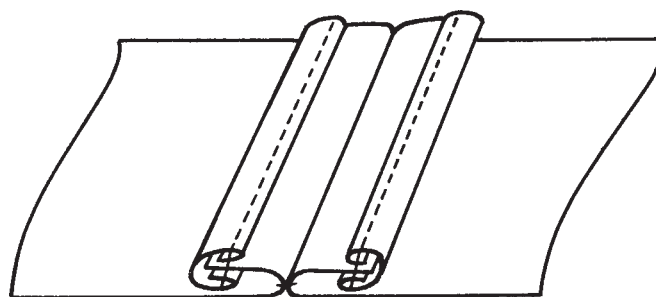

FIG. 1 Bound Seam Finish from Back Side of Fabric

seam allowances may be placed together and treated as one, such as the armscye seam allowances of an unlined jacket or on a bound neckline.

clean-finish seam finish, *n*—in home sewing, a seam finish in which the cut edge is folded under and the fold line is edge stitched. (See Fig. 2.) (Syn. **turned and stitched seam finish**.)

DISCUSSION—A clean-finish seam finish is made by (1) turning under each cut edge of a plain seam allowance approximately 3 to 6 mm ($\frac{1}{8}$ to $\frac{1}{4}$ in.) and (2) stitching close to the folded edge. A stabilizing line of stitching 3 to 6 mm from a curved cut edge will facilitate turning before stitching close to the fold.

complex seam, *n*—in home sewing, a seam made in two or more steps. (Ant. **plain seam**.)

DISCUSSION—Complex seams have one or more stitching lines as part of their construction and include double-welt seams, flat-felled seams, French seams, lapped seams, mock French seams, slot seams, tucked seams, and welt seams. They do not include plain seams or seam finishes or decorative additions to seams.

double-welt seam, *n*—in home sewing, a complex seam formed on the inside of the product, in which one trimmed seam allowance is enclosed and two rows of stitching are visible on the face side. (Compare **welt seam**. Syn. *mock flat-felled seam*.) (See Fig. 3.)

DISCUSSION—A double-welt seam is made like a welt seam except that it has a second row of topstitching close to the original seamline. The three rows of stitching visible on the back side are the original seam line, the row of stitching through the outermost layer of the sewn product and the wider of the seam allowances, and the row added near the original seam line.

edge-stitched seam finish, *n*—in home sewing, a seam finish in which machine stitching is placed close to the cut edge of

¹ This terminology is under the jurisdiction of ASTM Committee D13 on Textiles and is the direct responsibility of Subcommittee D13.53 on Practices.

Current edition approved Nov. 10, 1995 and February 10, 1996. Published July 1996. Originally published as D 4965 – 89a. Last previous edition D 4965 – 95.

² *Annual Book of ASTM Standards*, Vol 07.01.

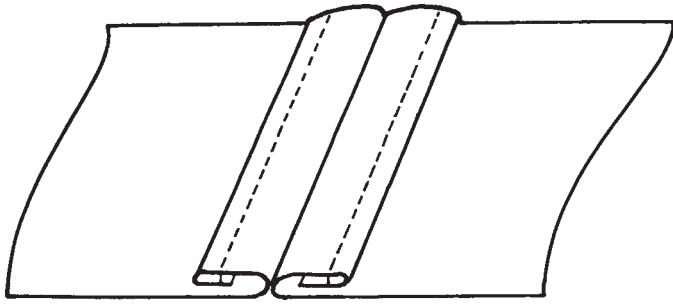

FIG. 2 Clean-Finish Seam Finish from Back Side of Fabric

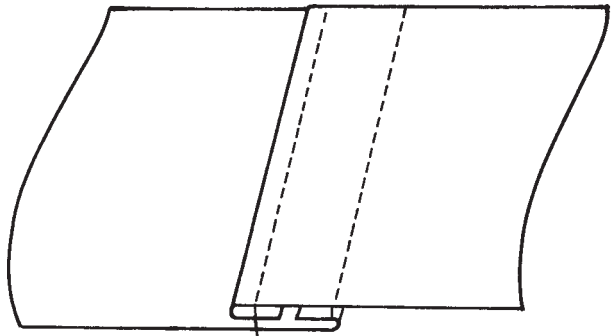

FIG. 5 Flat-Felled Seam from Face Side of Fabric

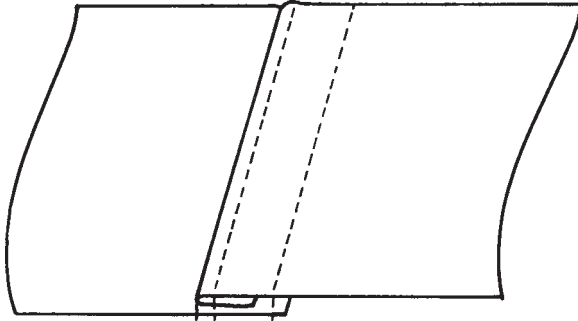

FIG. 3 Double-Welt Seam from Face Side of Fabric

each seam allowance. (Compare **zigzagged seam finish**.) (See Fig. 4.)

DISCUSSION—An edge-stitched seam finish is made by straight stitching approximately 3 to 6 mm ($\frac{1}{8}$ to $\frac{1}{4}$ in.) from each cut edge of each seam allowance.

face side, n—in textile materials, the side of the material that is outermost in the completed product. (Ant. **back side, wrong side**. Syn. *right side*.)

flat-felled seam, n—in home sewing, a complex seam formed on the outside of a product with cut edges enclosed and two rows of machine stitching visible from the face side. (See Fig. 5(a) and (b).)

DISCUSSION—A flat-felled seam is made by (1) stitching a basic seam with the back sides together, (2) pressing both seam allowances to one side, (3) trimming the under seam allowance to approximately $\frac{1}{8}$ in. (3 mm), (4) turning under the cut edge of the upper seam allowance, and (5) topstitching close to the fold.

French seam, n—in home sewing, a complex seam formed on the inside of a product with both cut edges enclosed and no

stitching rows visible on the face side. (Compare **mock French seam**.) (See Fig. 6.)

DISCUSSION—A French seam is made by (1) placing two sections of fabric with back sides together, (2) stitching a seam line 10 mm ($\frac{3}{8}$ in.) from the cut edges, (3) pressing the seam open, (4) trimming the seam allowance to 3 mm ($\frac{1}{8}$ in.) if the fabric does not ravel easily, or to slightly less than 6 mm ($\frac{1}{4}$ in.) if the fabric ravel easily, (5) clipping or notching the curved seam allowances such that they respectively will fit the larger or smaller area, against which they will be pressed, (6) folding the face sides of the fabric together, (7) pressing again with the stitched seamline exactly on the folded edge, and (8) stitching 6 mm from the folded edge. By using this procedure, the cut edges of the trimmed seam allowance are enclosed completely. The two seam allowances make a total of 15 mm ($\frac{3}{8}$ in.), the standard seam allowance width. No stitching lines are visible from the face side. French seams are more appropriate for straight seams than curved seams.

glued seam, n—in home sewing, a seam formed by the use of an adhesive. (Compare **sewn seam, stapled seam, thermally bonded seam**.)

DISCUSSION—Adhesive may be glue, heat-fusible web or powder, or hot glue.

hand-overcast seam finish, n—in home sewing, a seam finish in which hand stitches are sewn such that the thread wraps around the cut edges of each seam allowance. (See Fig. 7.)

DISCUSSION—A hand-overcast seam finish is made by using a needle and thread to form stitches that are approximately 6 mm ($\frac{1}{4}$ in.) apart and 3 to 6 mm ($\frac{1}{8}$ to $\frac{1}{4}$ in.) inside the cut edges of the seam allowance. The cut edge of each seam allowance is wrapped by the thread that passes over the edge.

Hong Kong seam finish, n—in home sewing, a seam finish in which a binding fabric is used to encase the cut edge of each seam allowance separately and in which the binding fabric

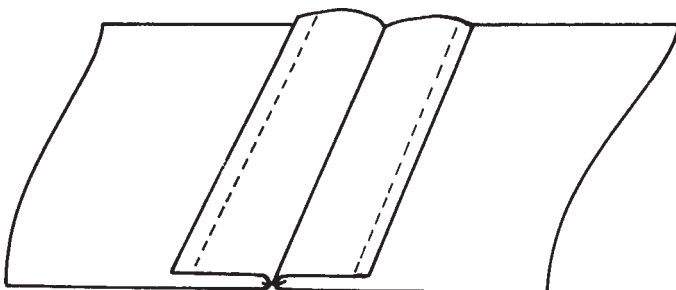

FIG. 4 Edge-Stitched Seam Finish from Back Side of Fabric

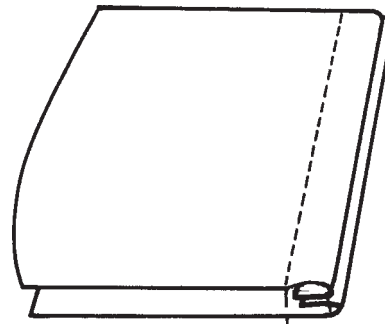

FIG. 6 French Seam from Back Side of Fabric

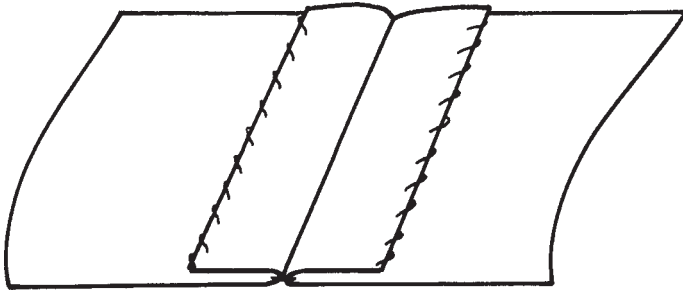

FIG. 7 Hand-Overcast Seam Finish from Back Side of Fabric

has one cut edge enclosed and the other cut edge exposed. (Compare **bound seam finish**.) (See Fig. 8.)

DISCUSSION—A Hong Kong seam finish is made by (1) selecting a strip of light weight bias-cut woven fabric, lightweight knit such as tricot or tulle, or commercial bias tape pressed open (25 mm (1 in.) wide), (2) placing the bias strip against a seam allowance, face sides together and cut edges even, (3) stitching 6 mm (¼ in.) from the cut edges, (4) pressing the binding away from the seam and over the cut edge toward the underside of the seam allowance, and (6) stitching in the previously formed stitching line on the face side of the seam allowance, thus securing the under layer of the folded binding to the under side of the seam allowance (sometimes called “stitch-in-the-ditch”). The excess binding fabric may be trimmed close to the stitching.

inside seam, n—in home sewing, a seam having seam allowances located within the interior, or the underside, of the product. (Compare **outside seam**.)

DISCUSSION—Examples of inside seams include double-welt seams, French seams, lapped seams, mock French seams, slot seams, tucked seams, and welt seams.

joining line, n—See **seam**.

lapped seam,— except the topstitching is farther from the fold than that of a lapped seam 6 to 10 mm (¼ to ⅜ in.).

turned and stitched seam finish, n—See **clean finished seam finish**.

lapped seam for leather or nonwoven material, n—in home sewing, a complex seam formed on the outside of the product, with neither cut edge enclosed and having one or two rows of stitching and a cut edge visible from the outside. (Compare **lapped seam for woven or knitted fabric**.) (See Fig. 9(a) and (d).)

DISCUSSION—A lapped seam for leather or nonwoven fabric is made by (1) marking the corresponding seamlines on both pieces, (2) trimming off the entire seam allowance (15 mm (⅝ in.)) on the overlap or top section, (3) lapping the cut edge of the trimmed overlap section

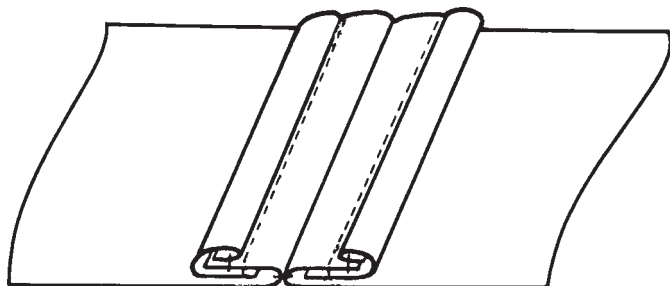

FIG. 8 Hong Kong Seam Finish from Back Side of Fabric

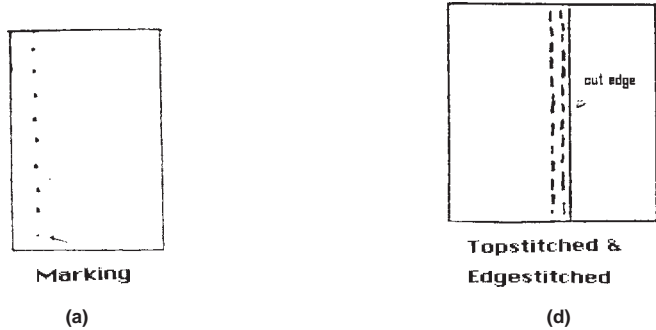

FIG. 9 Lapped Seam for Leather or Nonwoven Fabric from Face Side of Material

over the bottom section, butting the cut edge to the marked seamline beneath, and (4) gluing in place and topstitching with one or two rows of stitching. Both gluing and topstitching may be used. This seam is used on leather, nonwoven leather-like material, and vinyl where an exposed cut edge is not a concern.

lapped seam for woven or knitted fabric, n—in home sewing, a complex seam formed on the inside of the product with neither raw cut edge enclosed, and having one visible line of topstitching on the face side and a small fold formed by the topstitching. (Compare **tucked seam**.) (See Fig. 10.)

DISCUSSION—A lapped seam for woven or knitted fabric is made by (1) folding under the seam allowance of the overlapping section along the 15-mm (⅝-in.) seamline and pressing, then (2) working from the right side and pinning the folded edge over the underlap section with the fold along the seamline, and (3) stitching close to the fold through all layers. Basting before stitching may be needed.

material, n—in home sewing, a planar structure such as textile fabric, plastic film, or leather.

DISCUSSION—“Materials” used may include fabric, fur, leather and plastic film. Joining methods for seams may vary.

mock flat-felled seam, n—See **double-welt seam**.

mock French seam, n—in home sewing, a complex seam formed on the inside of the product with cut edges enclosed and no stitching visible on the face side; similar in appearance to the French seam but constructed differently. (Compare **French seam**.) (See Fig. 11.)

DISCUSSION—A mock French seam is made by (1) placing two pieces of fabric with face sides together, (2) stitching on the 15-mm (⅝-in.) seamline, (3) trimming both seam allowances to 12 mm (½ in.), (4) clipping or notching, as appropriate, 3 mm (⅛ in.) on any curved edges

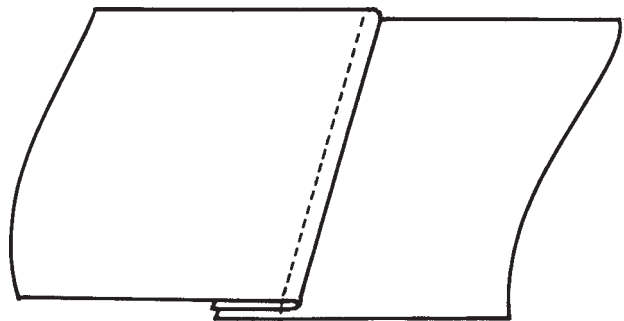

FIG. 10 Lapped Seam for Woven or Knitted Fabric from Face Side of Fabric

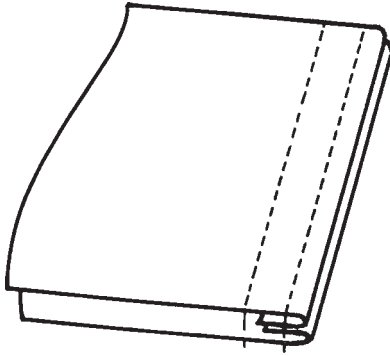

FIG. 11 Mock French Seam from Back Side of Fabric

so that curved seam allowances can fit the area against which they are folded and pressed, (5) pressing open the seam, (6) then folding and pressing each of the seam allowances 6 mm (¼ in.) toward the other and the seamline, bringing the folded edges together, and (7) stitching the two seam allowances together 1.5 mm (⅙ in.) from the folded edges. Mock French seams are more appropriate for curved areas than French seams.

outside seam, n—*in home sewing*, a seam in which the seam allowance of the completed seam is visible from the face side of the sewn product. (Compare **inside seam**.)

DISCUSSION—An example of an outside seam is the flat-felled seam.

plain seam, n—*in home sewing*, a seam formed by a single line of stitching. (Ant. **complex seam**.) (See Figs. 12 and 13.)

DISCUSSION—A plain seam joins two or more material sections; multiple layers of material may be treated as a single layer or section. Cut edges of the seam allowance in a plain seam may or may not have a finish applied. Sometimes a plain seam is reinforced by machine stitching again through both seam allowances together approximately 3 to 6 mm (⅛ to ¼ in.) from the original seam line within the seam allowance. Reinforcement is appropriate for armseye, crotch, and waistline seams. Reinforcement stitching may be along a section of a seam (as in a crotch seam) or along an entire seam (such as in a waistline seam). Seams that are reinforced are not pressed open.

pinked seam finish, n—*in home sewing*, a seam finish in which a zigzagged or scalloped cut edge is produced. (Compare **stitched and pinked seam finish**). (See Fig. 14).

DISCUSSION—A pinked seam finish is made by trimming, with pinking or scalloping shears, close to the cut edge of the seam allowance. This seam finish is more decorative than functional.

right side, n—See **face side**.

rolled seam finish, n—*in home sewing*, a seam finish in which both cut edges are enclosed by rolling them to one side and

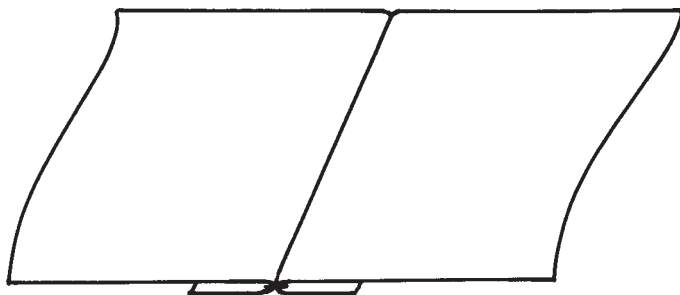

FIG. 12 a Plain Seam from Face Side of Material

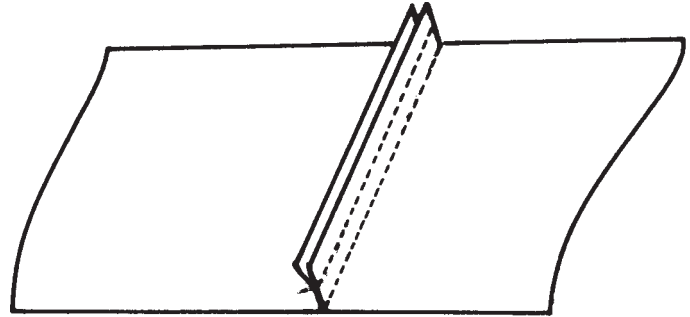

FIG. 13 b Plain Seam Reinforced from Back Side of Fabric

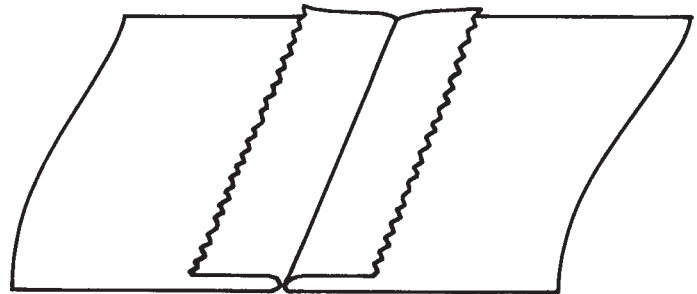

FIG. 14 Pinked Seam Finish from Back Side of Material

hand stitching the rolled edge close to the seam line within the seam allowance. (See Fig. 15.)

DISCUSSION—A rolled seam finish is made by (1) trimming the seam allowance to 10 mm (⅜ in.), (2) rolling the seam allowances together with thumb and forefinger to one side so that cut edges are enclosed, and (3) hand stitching the rolled edge close to the seam line within the seam allowance.

seam, n—*in home sewing*, a line along which two or more sections of a product have been joined. (Syn. *joining line*. See also **glued seam, sewn seam, stapled seam, thermally bonded seam**.)

DISCUSSION—Materials used may include fabric, fur, leather, and plastic film. Joining methods for seams may vary.

sealant-sealed seam finish, n—*in home sewing*, a seam finish in which a clear liquid seam-sealant is used as the treatment to prevent fraying.

DISCUSSION—Seam-sealant is used sparingly along the cut edges of seam allowances. The dried finish may not be visible or sensed by touch, depending on fabric and/or application.

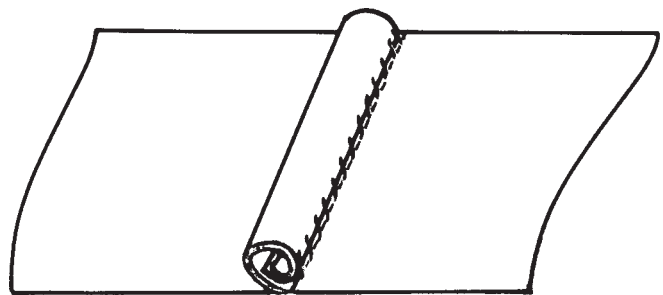

FIG. 15 Rolled Seam-Finish from Back Side of Fabric

seam allowance, *n*—*in sewn materials*, the width of material between the cut edge of a fabric section and the line parallel to the cut edge along which that section will be joined to another section during assembly of the finished product.

DISCUSSION—Many commercial patterns specify seam allowances of 15 mm (5/8 in.). However, the allowance width may vary, depending on the pattern. Seam allowances may be trimmed during or after seam construction.

seam finish, *n*—*in home sewing*, a treatment of the fabric cut edges of the seam allowance in a plain seam.

DISCUSSION—Types of seam finishes may include bound, clean-finished, double-stitched, edge-stitched, hand-overcast, Hong Kong, pinked, rolled, sealant-sealed, self-bound, stitched and pinked, turned and stitched, and zigzagged. Seam finishes are used to prevent fraying of cut edges, to provide a neater appearance, and to prolong wear life of the finished product. The type of seam finish chosen may be influenced by type and weight of fabric, amount and kind of care to be given, the product end use, the location and visibility of the seams, and the design of the product. Seam finishes are not needed with complex seams.

self-bound seam finish, *n*—*in home sewing*, a seam finish in which one seam allowance encloses both cut edges. (See Fig. 16.)

DISCUSSION—A self-bound seam finish is made by (1) stitching on the 15-mm (5/8-in.) seam line with face sides of fabric sections together, (2) trimming one seam allowance to 3 to 6 mm (1/8 to 1/4 in.), (3) folding the wider seam allowance edge under 3 to 6 mm, (4) turning the folded edge over the narrower seam allowance so the folded edge nearly abuts the seam line, thus enclosing all raw edges, and (5) machine stitching along the first folded edge through the four layers of the two seam allowances.

sewn seam, *n*—*in sewn materials*, a juncture along which two or more planar structures, such as textile material, are joined by sewing. (Compare **glued seam**, **stapled seam**, **thermally bonded seam**. Syn. **stitched seam**.)

*simple seam, *n**—See **plain seam**.

slot seam, *n*—*in home sewing*, a complex seam formed on the inside of the product, having a decorative seam underlay slightly visible from the face side, and held in place by two visible rows of stitching. (See Fig. 17.)

DISCUSSION—A slot seam is made by (1) machine basting the face sides of the material together 15 mm (5/8 in.) from the cut edges, (2) pressing open the seam, (3) centering the underlay (which is approximately 38 mm (1 1/2-in.) wide) under the open seam allowance, (4) topstitching two lines an equal distance (approximately 6 mm (1/4 in.))

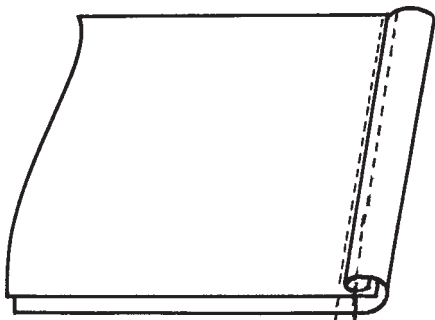

FIG. 16 Self-Bound Seam Finish from Back Side of Fabric

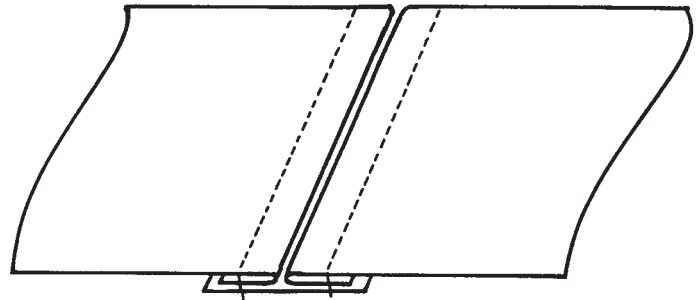

FIG. 17 Slot Seam from Face Side of Material

from the seamline on each side, and (5) removing the basting threads. The two rows of topstitching are visible from the face side.

stapled seam, *n*—*in home sewing*, a seam formed by shaped metal devices such as U-shaped staples. (Compare **glued seam**, **sewn seam**, **thermally bonded seam**.)

DISCUSSION—A stapled seam may be used in upholstery when fabrics are attached to a frame.

stitched and pinked seam finished, *n*—*in home sewing*, a seam finish in which a zigzagged or scalloped cut edge is reinforced by a line of stitching. (Compare **pinked seam finish**). (See Fig. 18.)

DISCUSSION—A stitched and pinked seam finish is made by first stitching 6 mm (1/4 in.) from the cut edge of each seam allowance and then trimming close to that stitching with pinking or scalloping shears. (See Fig. 18.)

stitched seam, *n*—See **seam seam**.

thermally bonded seam, *n*—*in home sewing*, a seam formed by the use of a heat-sensitive material that fuses two material sections together along a seam line when heat and pressure are applied. (Compare **glued seam**, **sewn seam**, **stapled seam**.)

topstitching, *n*—*in home sewing*, a line of stitching that is visible on the face side of the finished product, usually stitched while having the face side of the material uppermost.

trim, *v*—*in home sewing*, to cut off a narrow strip, width, or portion of a material, usually along a cut edge of a seam allowance.

tucked seam, *n*—*in home sewing*, a complex seam formed on the inside of the product with neither cut edge enclosed and having one visible line of topstitching on the face side and a

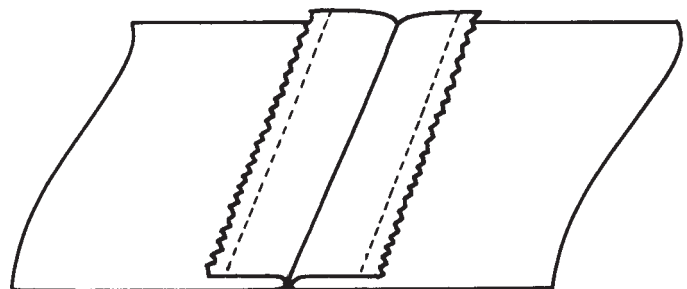

FIG. 18 Stitched and Pinked Seam Finish from Back Side of Fabric

visible free folded edge (tuck). (Compare **lapped seam**.) (See Fig. 19.)

DISCUSSION—A tucked seam is made in the same manner as the lapped seam, except the topstitching is farther from the fold than that of a lapped seam (6 to 10 mm (¼ to ⅜ in.)).

welt seam, n—*in home sewing*, a complex seam formed on the inside of the product with one trimmed cut edge enclosed and one stitching line visible on the face side. (See Fig. 20.)

DISCUSSION—A welt seam is made by (1) machine stitching the face sides of the material together 15 mm (⅝ in.) from the cut edge, (2) pressing open the seam allowance, (3) and then pressing both allowances to one side, (4) trimming the inner seam allowance nearer the

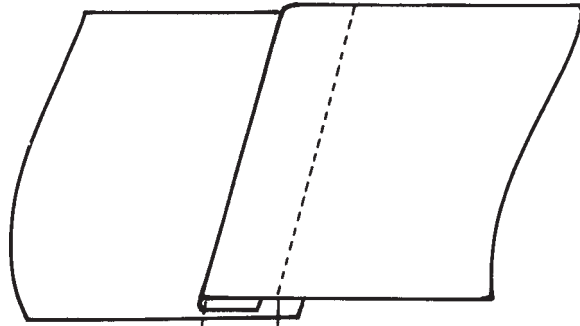

FIG. 20 Welt Seam from Face Side of Material

outermost layer of material to 6 mm (¼ in.), and (5) topstitching through the outermost layer of material and the wider seam allowance, thus enclosing the narrowly trimmed seam allowance. The two rows of stitching visible on the back side are the seam line and the topstitching.

wrong side, n—See **back side**.

zigzagged seam finish, n—*in home sewing*, a seam finish in which machine zigzag stitching is placed 3 to 6 mm (⅛ to ¼ in.) from each of the cut edges of the seam allowances. (Compare **edge-stitched seam finish**.) (See Fig. 21.)

DISCUSSION—A zigzagged seam finish is made by adjusting a sewing machine capable of producing a zigzag stitch so that the machine will stitch diagonally from side to side, creating a single stitch zigzag or multiple stitch zigzag near the edge of each seam allowance.

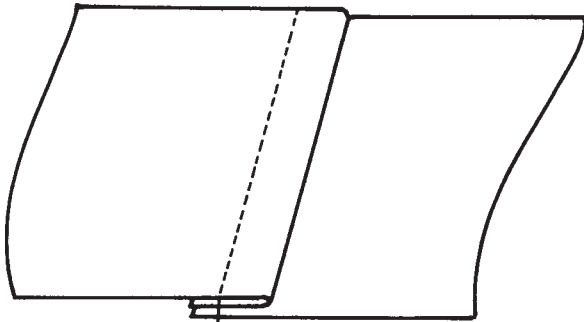

FIG. 19 Tucked Seam from Face Side of Fabric

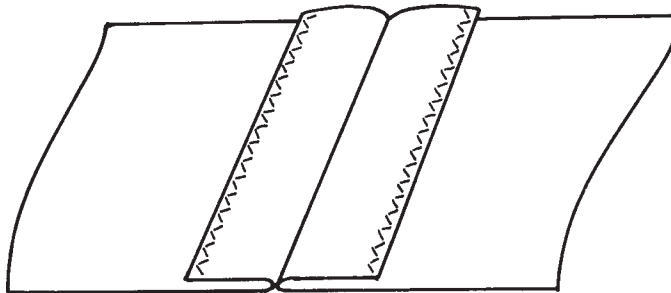

FIG. 21 Zigzagged Seam Finish from Back Side of Fabric

ASTM International takes no position respecting the validity of any patent rights asserted in connection with any item mentioned in this standard. Users of this standard are expressly advised that determination of the validity of any such patent rights, and the risk of infringement of such rights, are entirely their own responsibility.

This standard is subject to revision at any time by the responsible technical committee and must be reviewed every five years and if not revised, either reapproved or withdrawn. Your comments are invited either for revision of this standard or for additional standards and should be addressed to ASTM International Headquarters. Your comments will receive careful consideration at a meeting of the responsible technical committee, which you may attend. If you feel that your comments have not received a fair hearing you should make your views known to the ASTM Committee on Standards, at the address shown below.

This standard is copyrighted by ASTM International, 100 Barr Harbor Drive, PO Box C700, West Conshohocken, PA 19428-2959, United States. Individual reprints (single or multiple copies) of this standard may be obtained by contacting ASTM at the above address or at 610-832-9585 (phone), 610-832-9555 (fax), or service@astm.org (e-mail); or through the ASTM website (www.astm.org).