



Standard Practice for NaI(Tl) Gamma-Ray Spectrometry of Water¹

This standard is issued under the fixed designation D4962; the number immediately following the designation indicates the year of original adoption or, in the case of revision, the year of last revision. A number in parentheses indicates the year of last reapproval. A superscript epsilon (ϵ) indicates an editorial change since the last revision or reapproval.

1. Scope

1.1 This practice covers the measurement of radionuclides in water by means of gamma-ray spectrometry. It is applicable to nuclides emitting gamma-rays with energies greater than 50 keV. For typical counting systems and sample types, activity levels of about 40 Bq (1080 pCi) are easily measured and sensitivities of about 0.4 Bq (11 pCi) are found for many nuclides **(1-10)**.² Count rates in excess of 2000 counts per second should be avoided because of electronic limitations. High count rate samples can be accommodated by dilution or by increasing the sample to detector distance.

1.2 This practice can be used for either quantitative or relative determinations. In tracer work, the results may be expressed by comparison with an initial concentration of a given nuclide which is taken as 100 %. For radioassay, the results may be expressed in terms of known nuclidic standards for the radionuclides known to be present. In addition to the quantitative measurement of gamma-ray activity, gamma-ray spectrometry can be used for the identification of specific gamma-ray emitters in a mixture of radionuclides. General information on radioactivity and the measurement of radiation has been published **(11 and 12)**. Information on specific application of gamma-ray spectrometry is also available in the literature **(13-16)**.

1.3 The values stated in SI units are to be regarded as standard. No other units of measurement are included in this standard.

1.4 *This standard does not purport to address all of the safety concerns, if any, associated with its use. It is the responsibility of the user of this standard to establish appropriate safety and health practices and determine the applicability of regulatory limitations prior to use.*

¹ This practice is under the jurisdiction of ASTM Committee D19 on Water and is the direct responsibility of Subcommittee D19.04 on Methods of Radiochemical Analysis.

Current edition approved Feb. 1, 2009. Published March 2009. Originally approved in 1989. Last previous edition approved in 2002 as D4962 – 02. DOI: 10.1520/D4962-02R09.

² The boldface numbers in parentheses refer to the references at the end of this practice.

2. Referenced Documents

2.1 *ASTM Standards*:³

- D3648 Practices for the Measurement of Radioactivity
- D4962 Practice for NaI(Tl) Gamma-Ray Spectrometry of Water
- E181 Test Methods for Detector Calibration and Analysis of Radionuclides

3. Summary of Practice

3.1 Gamma-ray spectra are commonly measured with modular equipment consisting of a detector, amplifier, multi-channel analyzer device, and a computer**(17 and 18)**.

3.2 Thallium-activated sodium-iodide crystals, NaI(Tl), which can be operated at ambient temperatures, are often used as gamma-ray detectors in spectrometer systems. However, their energy resolution limits their use to the analysis of single nuclides or simple mixtures of a few nuclides. Resolution of about 7 % (45 keV full width at one half the ¹³⁷Cs peak height) at 662 keV can be expected for a NaI(Tl) detector in a 76 mm by 76 mm-configuration.

3.3 Interaction of a gamma-ray with the atoms in a NaI(Tl) detector results in light photons that can be detected by a multiplier phototube. The output from the multiplier phototube and its preamplifier is directly proportional to the energy deposited by the incident gamma-ray. These current pulses are fed into an amplifier of sufficient gain to produce voltage output pulses in the amplitude range from 0 to 10 V.

3.4 A multichannel pulse-height analyzer is used to determine the amplitude of each pulse originating in the detector, and accumulates in a memory the number of pulses in each amplitude band (or channel) in a given counting time**(17 and 18)**. For a 0 to 2 MeV spectrum two hundred data points are adequate.

3.5 The distribution of the amplitudes (pulse heights) of the pulse energies, represented by the pulse height, can be separated into two principal components. One of these components has a nearly Gaussian distribution and is the result of total

³ For referenced ASTM standards, visit the ASTM website, www.astm.org, or contact ASTM Customer Service at service@astm.org. For *Annual Book of ASTM Standards* volume information, refer to the standard's Document Summary page on the ASTM website.

absorption of the gamma-ray energy in the detector; this peak is normally referred to as the full-energy peak or photopeak. The other component is a continuous one, lower in energy than the photopeak. This continuous curve is referred to as the Compton continuum and results from interactions wherein the gamma photons lose only part of their energy to the detector. Other peaks components, such as escape peaks, backscattered gamma-rays, or x-rays from shields, are often superimposed on the Compton continuum. These portions of the curve are shown in Fig. 1 and Fig. 2. Escape peaks will be present when gamma-rays with energies greater than 1.02 MeV are emitted from the sample (19-24). The positron formed in pair production is usually annihilated in the detector and one or both of the 511 keV annihilation quanta may escape from the detector without interaction. This condition will cause single- or double-escape peaks at energies of 0.511 or 1.022 MeV less than the photopeak energy. In the plot of pulse height versus count rate, the size and location of the photopeak on the pulse height axis is proportional to the number and energy of the incident photons, and is the basis for the quantitative and qualitative application of the spectrometer. The Compton continuum serves no useful quantitative purpose in photopeak analysis and must be subtracted from the photopeak to obtain the correct number of counts before peaks are analyzed.

3.6 If the analysis is being directed and monitored by an online computer program, the analysis period may be termi-

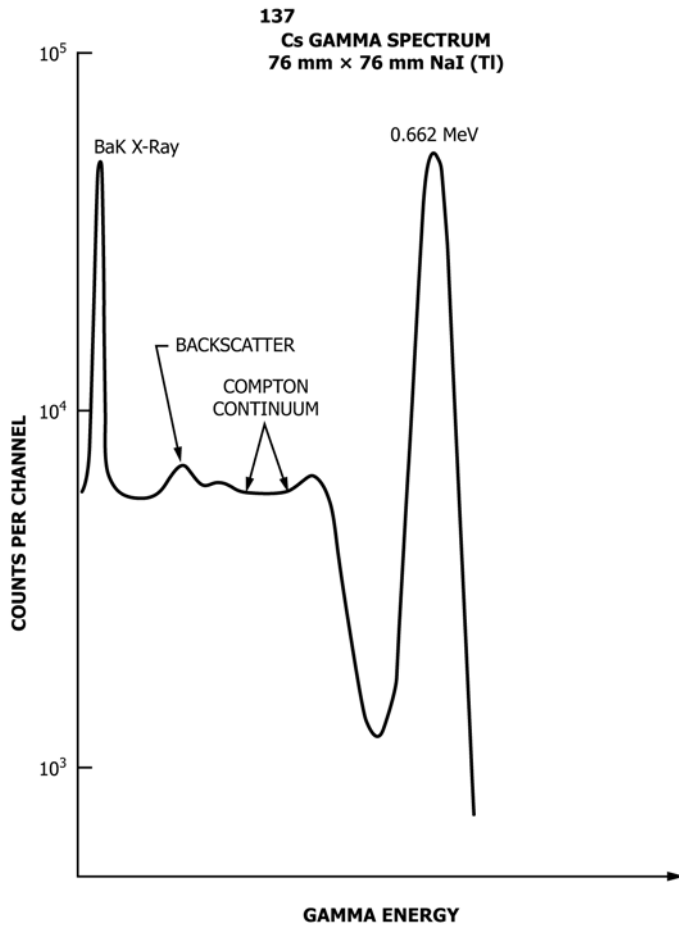

FIG. 1 Compton Continuum

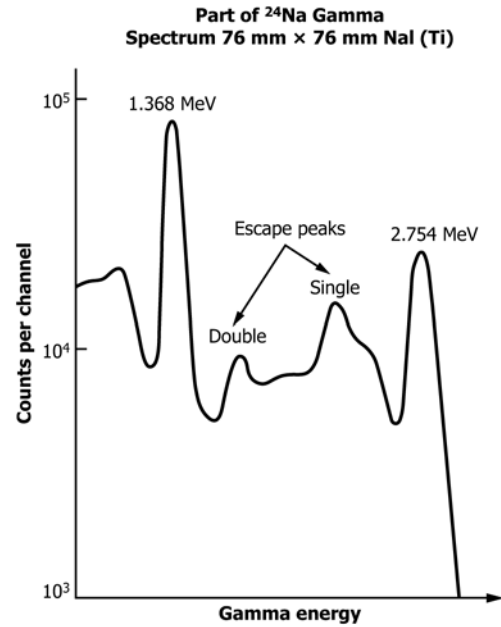

FIG. 2 Single and Double Escape Peaks

nated by prerequisites incorporated in the program. Analysis may also be terminated when a preselected time or total counts in a region of interest or in a specified channel is reached. Visual inspection of the computer monitor can also be used as a criterion for manually terminating the analysis.

3.7 Upon completion of the analysis, the spectral data are interpreted and reduced to nuclide activity of becquerels (disintegrations per second) or related units suited to the particular application. At this time, the spectral data may be inspected on the monitor to identify the gamma-ray emitters present. This is accomplished by reading the channel number from the x-axis and converting to gamma-ray energy by means of an equation relating channel number and gamma-ray energy. If the system is calibrated for 10 keV per channel with channel zero representing 0 keV, the energy can be immediately calculated. In some systems the channel number or gamma-ray energy in keV can be displayed on the monitor for any selected channel. Identification of nuclides may be aided by libraries of gamma-ray spectra and other nuclear data tabulations (25-30).

3.7.1 Data reduction of spectra involving mixtures of nuclides is usually accomplished using a library of standard spectra of the individual nuclides acquired under conditions identical to that of the unknown sample (25-30).

4. Significance and Use

4.1 Gamma-ray spectrometry is used to identify radionuclides and to make quantitative measurements. Use of a computer and a library of standard spectra will be required for quantitative analysis of complex mixtures of nuclides.

4.2 Variation of the physical geometry of the sample and its relationship with the detector will produce both qualitative and quantitative variations in the gamma-ray spectrum. To adequately account for these geometry effects, calibrations are designed to duplicate all conditions including source-to-detector distance, sample shape and size, and sample matrix

encountered when samples are measured. This means that a complete set of library standards may be required for each geometry and sample to detector distance combination that will be used.

4.3 Since some spectrometry systems are calibrated at many discrete distances from the detector, a wide range of activity levels can be measured on the same detector. For high-level samples, extremely low efficiency geometries may be used. Quantitative measurements can be made accurately and precisely when high activity level samples are placed at distances of 1 m or more from the detector.

4.4 Electronic problems, such as erroneous deadtime correction, loss of resolution, and random summing, may be avoided by keeping the gross count rate below 2 000 counts per second and also keeping the deadtime of the analyzer below 5 %. Total counting time is governed by the activity of the sample, the detector source distance, and the acceptable Poisson counting uncertainty.

5. Interferences

5.1 In complex mixtures of gamma-ray emitters, the degree of interference of one nuclide in the determination of another is governed by several factors. If the gamma-ray emission rates from different radionuclides are similar, interference will occur when the photopeaks are not completely resolved and overlap. A method of predicting the gamma-ray resolution of a detector is given in the literature (31). If the nuclides are present in the mixture in unequal portions radiometrically, and nuclides of higher gamma-ray energies are predominant, there are serious interferences with the interpretation of minor, less energetic gamma-ray photopeaks. The complexity of the analysis method is due to the resolution of these interferences and, thus, one of the main reasons for computerized systems.

5.2 Cascade summing may occur when nuclides that decay by a gamma-ray cascade are analyzed. Cobalt-60 is an example; 1172 and 1333 keV gamma-rays from the same decay may enter the detector to produce a sum peak at 2505 keV and cause the loss of counts from the other two peaks. Cascade summing may be reduced by increasing the source to detector distance. Summing is more significant if a well-type detector is used.

5.3 Random summing occurs in all measurements but is a function of count rate. The total random summing rate is proportional to the square of the total number of counts. For most systems, random summing losses can be held to less than 1 % by limiting the total counting rate to 2 000 counts per second (see Methods E181).

5.4 The density of the sample is another factor that can affect quantitative results. This source of error can be avoided by preparing the standards for calibration in matrices of the same density of the sample under analysis.

6. Apparatus

6.1 *Gamma Ray Spectrometer*, consisting of the following components, as shown in Fig. 3:

6.1.1 *Detector Assembly*—Sodium iodide crystal, activated with about 0.1 % thallium iodide, cylindrical, with or without

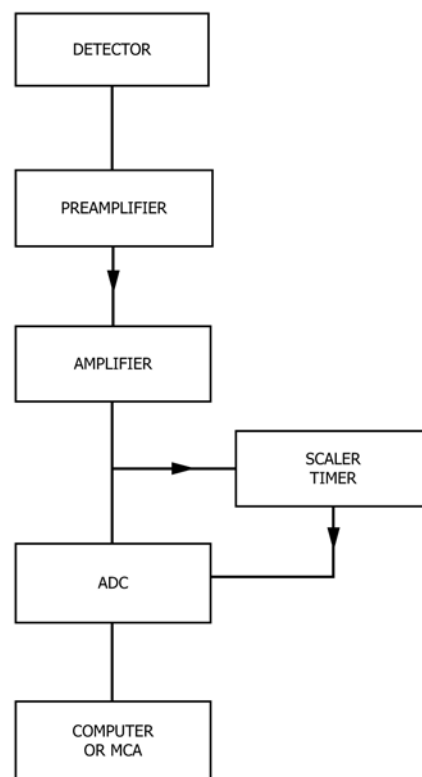

FIG. 3 Gamma Spectrometry System

an inner sample well, 51 to 102 mm in diameter, 44 to 102 mm high, and hermetically sealed in an opaque container with a transparent window. The crystal should contain less than 5 µg/g of potassium, and should be free of other radioactive materials. In order to establish freedom from other radioactive materials, the manufacturer should supply the gamma-ray spectrum of the background of the crystal between 80 and 3000 keV. The crystal should be attached and optically coupled to a photomultiplier. (The photomultiplier requires a preamplifier or a cathode follower compatible with the amplifier). The resolution (FWHM) of the assembly for the photopeak of cesium-137 should be less than 9 %.

6.1.2 *Shield*—The detector assembly shall be surrounded by an external radiation shield made of massive metal, equivalent to 102 mm of lead in gamma-ray attenuation capability. It is desirable that the inner walls of the shield be at least 127 mm distant from the detector surfaces to reduce backscatter. If the shield is made of lead or a lead liner, the shield must have a graded inner shield of 1.6 mm of cadmium or tin lined with 0.4 mm of copper, to attenuate lead x-rays at 88 keV, on the surface near the detector. The shield must have a door or port for inserting and removing samples.

6.1.3 *High Voltage Power/Bias Supply*—High-voltage power supply of range (usually from 500 to 3000 V and up to 10 mA) sufficient to operate a NaI(Tl) detector, photomultiplier, and its preamplifier assembly. The power supply shall be regulated to 0.1 % with a ripple of not more than 0.01 %. Line noise caused by other equipment shall be removed with radiofrequency filters and additional regulators.

6.1.4 *Amplifier*—An amplifier compatible with the preamplifier or emitter follower and with the pulse-height analyzer.

6.1.5 *Data Acquisition and Storage Equipment*—A multi-channel pulse-height analyzer (MCA) or stand-alone analog-to-digital-converter (ADC) under software control of a separate computer, performs many functions required for gamma-ray spectrometry. An MCA or computer collects the data, provides a visual display, and outputs final results or raw data for later analysis. The four major components of an MCA are the ADC, the memory, the control, and the input/output circuitry and devices. The ADC digitizes the analog pulses from the detector amplifier. These pulses represent energy. The digital result selects a memory location (channel number) which is used to store the number of events which have occurred with that energy. Simple data analysis and control of the MCA is accomplished with microprocessors, which control factors such as the input/output, channel summing over set regions of interest, and system energy calibration.

6.1.6 *Data Storage*— Because of the use of microprocessors, modern MCAs provide a wide range of input and output (I/O) capabilities. Typically, these include the ability to transfer any section of data to one or more of the following: printer, floppy or hard disk, x-y plotter, and computer interfaces by way of a serial, parallel, ethernet or USB port.

7. Container for Test Specimen

7.1 Sample mounts and containers must have a convenient reproducible geometry. Considerations include commercial availability, ease of use and disposal, and the containment of radioactivity for protection of the working environment and personnel from contamination. The evaporation of liquid samples to dryness is not necessary and liquid samples up to several litres may be used. However, samples that have been evaporated to dryness for gross beta counting can also be used for gamma-ray spectrometry. Massive samples may cause significant self-absorption of low-energy gamma-rays and degrade the higher-energy gamma-rays. Therefore, it is important to calibrate the detector with standards of the same geometry and density. A beta absorber consisting of about 6 mm of aluminum, beryllium, or plastic may be used for samples that have a significant beta activity and high beta energies.

8. Single or Simple Mixtures of Radionuclides

8.1 Calibration and Standardization :

8.1.1 Begin operation of the instrumentation and detector according to the manufacturer's instructions. Initial set-up includes all electronic adjustment to provide constant operating conditions consistent with the application and life expectancy of the calibrations. Adjust the analog-to-digital converter gain and threshold, amplifier gain and zero-level, and detector high voltage, or bias, to yield an optimum energy calibration, usually 10 keV per channel. Modern commercial equipment is capable of linearity to the extent that the energy may be interpreted by the operator directly to the nearest 5 keV simply by reading the channel number of the highest channel in a peak. The energy calibration is usually accomplished with radioactive sources covering the entire range of interest. All efficiency calibrations and source analyses are performed with the same gain settings and the same high voltage setting.

Obtain efficiency calibrations by placing an appropriate volume of an NIST traceable radionuclide standard solution containing 100 to 10 000 Bq in a container and placing the container on the detector or in the detector well.

8.1.2 Preparation of Apparatus:

8.1.2.1 Follow the manufacturer's instructions, limitations, and cautions for the set up of and the preliminary testing for all of the spectrometry equipment to be used in the analysis. This equipment could include detectors, power supplies, preamplifiers, amplifiers, multichannel analyzers, and computing systems.

8.1.2.2 Place an appropriate volume of an NIST traceable standard or an NIST traceable mixed standard of radionuclides in a sealed container and place the container at a desirable and reproducible source-to-detector distance. The solution above should provide about 100 counts per second in the peaks of interest. In all radionuclide measurements, the volumes, shape, and physical and chemical characteristics of the samples, and the corresponding standard, and their containers must be as identical as practicable for the most accurate results. If precipitates or residues are to be analyzed, then evaporate the standards on the same type of mount as the sample.

8.1.3 Energy Calibration:

8.1.3.1 Multichannel analyzers and NaI(Tl) detectors being produced today are capable of producing an almost linear energy response.

8.1.3.2 The energy calibration (channel number of the multichannel analyzer versus the gamma-ray energy) of the detector system is accomplished at a fixed gain using standards containing known radionuclides. The standards should be in sealed containers and should emit at least four different gamma-ray energies covering the range of interest, usually 50 keV to 2000 keV in order to test for system linearity. Some commercially available nuclides suitable for energy calibration are: ^{210}Pb , 46.5 keV; ^{241}Am , 59.5 keV; ^{109}Cd , 88 keV; ^{141}Ce , 145 keV; ^{51}Cr , 320 keV, ^{137}Cs , 662 keV, ^{54}Mn , 835 keV; ^{22}Na , 511 and 1275 keV; ^{88}Y , 898 and 1836 keV; ^{60}Co , 1173 and 1332 keV; equilibrated ^{226}Ra , 186, 352, 609, 1120, and 1765 keV; others have been listed (**17 and 18**). Verify the radionuclide purity of the standards periodically to ensure against accidental contamination or the presence of long lived impurities by comparing the observed spectra with the spectra published in the literature (**17 and 18**).

8.1.3.3 Calibrate the multichannel analyzer to cover the range of interest. If the range is 50 to 2000 keV, adjust the gain of the system until the ^{137}Cs photopeak, 662 keV, is about one-third full scale. Leaving the gain constant, locate at least three other photopeaks of different energies, covering the same range. Calibrate the system based upon the manufacturer's instructions of at least two, and preferably three, photopeaks. A near linear relationship will be observed if the equipment is operating properly. Samples should not be analyzed if there is a significant non-linear relationship. If the spectrometry system is computerized, follow the appropriate manufacturer input instructions for the determination of the slope and intercept. During each day in which the spectrometry system is being used to analyze samples, repeat the above sequence of operations using at least two different gamma-ray energies. If the

slope and intercept are essentially unchanged, the energy calibration data remain valid. If an appreciable change in the slope or intercept is evident, rerun the entire calibration procedure. For low-level samples counted over the course of several days, monitor the position of two peaks, for example, the 511 keV annihilation peak and ^{40}K (1460 keV). If these remain constant the system is assumed to be operating properly.

8.1.4 *Photon Detection Efficiency Calibration:*

8.1.4.1 Accumulate an energy spectrum using sealed, calibrated radioactive standards in a desired and reproducible counting geometry (see Section 8.1.2.2). Accumulate at least 10 000 net counts (total counts minus the Compton continuum and ambient background) in each full-energy gamma-ray peak of interest. Compare the live time of the count to the half-life of the radionuclide of interest. If the live time is a significant portion of the half-life, apply a correction factor for decay during the count (25-30).

8.1.4.2 Correct the radioactivity standard source gamma-ray emission rate for the decay from the time of standardization to the time at which the count rate is measured.

8.1.4.3 Calculate the full-energy peak efficiency using the observed net count rate in the full energy peak and the gamma-ray emission rate of the standard source. The gamma-ray emission rate being the product of the known nuclide activity and fraction of decays producing the respective full-energy emission. Practice D4962 presents equations for this purpose in sections 11 and 41.

8.1.4.4 Many modern spectrometry systems are computerized and the determination of the gamma-ray efficiencies are

determined automatically at the end of an appropriate counting interval. Refer to the manufacturer’s instructions for specific input requirements.

8.1.4.5 Plot the values for the full-energy peak efficiency versus gamma-ray energy. The plot will allow the determination of efficiencies at energies for which standards are not available and to show that the algorithms used in computerized systems are providing valid efficiency calibrations. A typical plot is shown in Fig. 4.

8.1.4.6 Once the efficiencies have been determined, it is unnecessary to recalculate them unless there is a change in resolution, geometry, or system configuration. However, count a standard of a long-lived nuclide such as Cs-137 periodically as a quality control check. (See Section 13.)

9. Complex Mixtures of Radionuclides

9.1 Because of the inherent energy resolution of NaI(Tl) detectors, gamma-ray peaks in complex mixtures of nuclides may not be separated sufficiently for quantification as outlined in Section 8. It may not even be possible to visually locate individual peaks if their energies are similar or their intensity is too low in relation to other gamma-rays present in the spectrum. Complex mixtures of as many as 10 to 20 radionuclides can be quantified mathematically with computer programs using a linear least squares technique (1-10).

9.1.1 When using these techniques care should be given to the following recommendations:

9.1.1.1 *System Gain and Zero Energy Channel*—Monitor and record the exact gain and zero energy channel of the spectrometer. If the computer analysis program performs gain

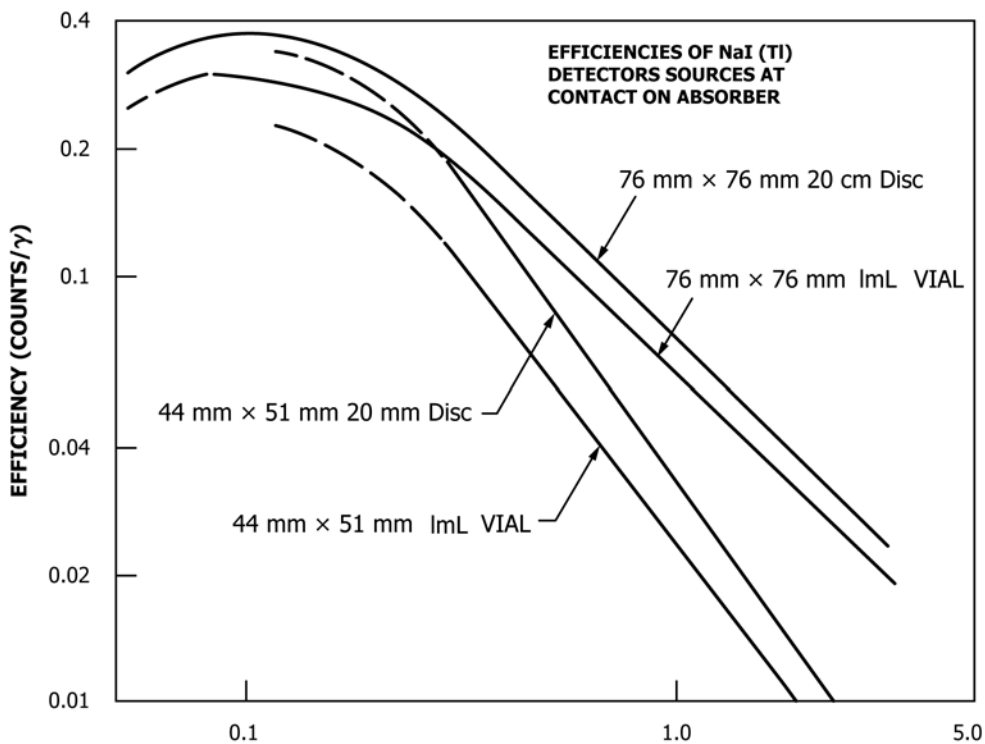

FIG. 4 Gamma Energy (MeV)

or base line (zero energy channel) corrections, or both, on sample data, then the library of standards data must be obtained under uniform and precise calibration conditions.

9.1.1.2 *Library Standards*—The least squares analysis technique is a linear combination of all of the data contained in the standards library. Therefore, the standards library must contain a spectra of every component in the sample; in addition, these spectra must be obtained from the purest radionuclides available.

9.1.1.3 *Counting of Library Standards* :

(a) All gamma-ray spectra will contain a background component. The activity of the library standards must be high enough so that this background component will be insignificant even though all computer programs make some kind of a background correction.

(b) The duration of the counting period for the standard library spectra should be long enough to obtain statistically valid data but short enough so that analyzer gain and base line drifts are insignificant.

(c) The activity of the library standards should be chosen so that the counting rates of the predominant photopeaks are all about the same.

9.1.1.4 *Data Plot*—A very important data evaluation technique to be used with a least squares program is a superimposed plot of the original sample data and the computed spectral data. A plot of residuals (the difference between the original and computed spectra) is also very important. The residuals plot is very sensitive to fitting errors when radionuclides present in the sample have been omitted from the library standards.

10. Sample Measurements

10.1 After setting up the spectrometer system, and performing the energy and efficiency calibrations or obtaining individual pulse-height spectra for nuclides expected to be present in samples, measure and quantify unknown specimens.

10.2 Following the general concepts of quantitative analytical chemistry, transfer the sample to the specimen container (see Section 7) and position it in the same manner as was done during system calibration (see Section 8).

10.3 Measure the sample for a period of time long enough to acquire a gamma-ray spectrum which will meet the minimum acceptable counting uncertainty.

11. Calculation

11.1 In many experiments, the background may not affect the results but is still monitored to ensure the integrity of the system. Again, the practice presented here is not the only option, but it is conducive to available software.

11.2 The underlying aim of this practice is to subtract the continuum or baseline from the spectral data where it underlies a photopeak of interest. Computer programs accomplish this but are not presented here.

11.3 Photopeaks lying on a sloping baseline or one with curvature will be analyzed with uncertainty in any practice. Use of data from these peaks should be limited to those cases where there is no other alternative. Photopeaks that overlap

with each other will also increase the uncertainty of the final result. In the case where use of overlapping peaks cannot be avoided, the analyst may estimate the areas by assuming that the ratio of the peak areas is equal to the ratio of the peak heights. Computer programs separating overlapping peaks with varying degrees of success are reported in the literature (25-30).

11.4 In order to determine nuclide concentrations, the photopeak areas corrected for background and interferences are divided by the count time and efficiency for the energy of the gamma-ray being calculated to give gamma-ray per second for the peak of interest. If, as is the case for some nuclides, the branching ratio is not accurately known and a direct calibration was made with the same nuclide, the branching ratio and efficiency will be one number that converts counts per second to disintegrations per second for the nuclide and photopeak of interest. If not, the gamma-rays per second are converted to disintegrations per second by dividing by the gamma-rays per disintegration, for the nuclide and photopeak of interest. The results are then corrected for sampling or decay, or both, as demanded by the application.

11.5 A simple gamma-ray spectrum containing only a few non-interfering radionuclides can be quantified by the procedures above. However, for complex spectra, the least squares method of analysis and a computer are required. In order to calculate the radionuclide abundance in a mixture by the method of least squares the sample spectrum is estimated by linearly summing the known pulse height distributions of each component. Therefore, for the least squares method to be used, the pulse height distribution and the identity of each component must be known. This information is generally known from the history of the sample and a visual analysis of the gamma-ray spectrum (32-37).

12. Precision and Bias

12.1 This practice is typically utilized for the measurement of a single radionuclide within a water sample or of a radiotracer within a final matrix to determine the chemical yield following a detailed radiochemical purification. In some applications, this practice may be used for the quantitative determination of one to five gamma-ray-emitting nuclides within a wide range of water sample types. The concentration ranges and half-lives of the individual nuclides present in a given sample may vary over several orders of magnitude giving rise to very complex gamma-ray spectra. Therefore, developing a round robin test plan germane to all reasonable applications would not be practical. However, a limited single operator test for a more simple spectral analysis using a weighted least squares approach has been conducted.

12.1.1 When this practice is used to determine the chemical yield of a standard test method by radiotracer addition, the precision and bias of the NaI(Tl) gamma-ray measurement would be inherent within the precision and bias of the individual standard test method. Therefore, refer to the precision and bias statements for the individual test methods.

12.2 Precision and bias of this practice is influenced by random counting uncertainties and by the uncertainties (or

errors) arising from interferences of the individual components of the spectrum with each other. The more complex the spectrum, the greater the errors, and, in general, major components can be determined more precisely than minor ones. As an example of the bias and precision that can be obtained from a weighted least squares analysis of a simple spectrum, a single operator test was performed on a water matrix containing ^{137}Cs , ^{54}Mn , and ^{65}Zn . Two separate water samples having different concentration levels of the three nuclides were repeatedly analyzed and the spectra resolved using weighted least squares techniques. Concentrations ranged between 15.3 and 122.8 Bq/L. The results of the single operator test have been presented in [Table 1](#).

12.3 Information on the calculation of uncertainty of results is presented in section 10 of Practices [D3648 \(19-24, 38\)](#).

TABLE 1 Single Operator Precision and Bias Data for NaI(Tl) Spectral Analyses using a Weighted Least Squares Statistical Technique

Sample	Number of Replicate Analyses	Nuclide	Amount Added, Bq/L	Amount Measured, Bq/L	Bias, %	Coefficient of Variation, %
A	23	^{137}Cs	122.8	123.3± 0.7	+ 0.4	0.6
		^{54}Mn	37.0	36.7± 0.5	-0.8	1.4
		^{65}Zn	50.1	50.3± 0.8	+ 0.4	1.6
B	17	^{137}Cs	49.9	50.6 ± 1.1	+ 1.4	2.2
		^{54}Mn	15.0	15.3± 0.3	+ 2.0	2.0
		^{65}Zn	20.4	21.3± 0.6	+ 4.4	2.8

13. Quality Control

13.1 Before this practice is utilized for the analysis of samples, a control or tolerance chart should be prepared as recommended in Practices [D3648](#) to ensure that the gamma-ray spectrometry system is operating within the prescribed limits. A check source shall be analyzed at a prescribed frequency, such as daily for high activity samples, or weekly for long count duration low-level samples, when the gamma-ray spectrometer is utilized for sample analysis. The results of the standard analysis shall be plotted on the control chart or tolerance chart and evaluated as recommended in Practices [D3648](#).

13.2 In addition, other system parameters such as resolution (FWHM) and gain may be trended in order to evaluate instrument performance.

13.3 The system background should be evaluated periodically. The background count data should be maintained in a logbook or plotted on a trend chart. A high background count can indicate an instrument problem or detector contamination.

13.4 Precision and bias can be assessed in the following manner: the precision of an individual measurement can be approximated by the counting uncertainty, and the bias can be assessed by the analysis of spiked samples.

14. Keywords

14.1 gamma pulse height analysis; gamma ray spectrometry; multichannel analyzer; sodium iodide detector

REFERENCES

- (1) Salmon, L., "Computer Analysis of Gamma-Ray Spectra from Mixtures of Known Nuclides by the Method of Least Squares," National Academy of Sciences Report NAS-N5-3107.
- (2) Helmer, R. C., Heath, R. L., Metcalf, D. C., and Corzier, G. A., "A Linear Least-Squares Computer Program for the Analysis of Gamma-Ray Spectra Including a Gain-shift Routine," Report IDO-17015, 1964.
- (3) Schonfeld, E., "Alpha M—An Improved Computer Program for Determining Radioisotopes by Least-Squares Resolution of Gamma-Ray Spectra," Report ORNL-3975, 1966.
- (4) Schmadebeck, R., and Trombka, J. I., "A Numerical Least-Squared Method for Resolving Complex Pulse Height Spectra," Report X-641-67-184, Goddard Space Flight Center.
- (5) Shumway, R. H., "Radionuclide Analysis of Gamma-Ray Spectra by Stepwise Multiple Regression," Public Health Service Publication No. 999-R-5.
- (6) Sanderson, C. G., "WLSQE—A Weighted Least-Squares Program for the Analysis of Complex Gamma-Ray Spectra," Environmental Measurements Laboratory Procedures manual, 25th ed., H. L. Volchok and G. de Planque, eds., Report EML-300, U. S. Department of Energy, 1982.
- (7) Kanipe, L. G., Seale, S. K., and Liggett, W. S., "Least-squares Resolution of Gamma-Ray Spectra in Environmental Monitoring," U. S. Environmental Protection Agency Report EPA-600/7-77-0 89.
- (8) Pestaner, J. F., and Love, D. L., "A Computer Program for Identifying and Measuring Components in a Mixture of Gamma-Emitting Radionuclides," U. S. Naval Radiological Defense Laboratory Report USNRDL-TR-67-46.
- (9) Korthoven, P. J. M., "RESOLF, A Computer Program for the Analysis of Gamma-Ray Spectra," Ames Laboratory Report IS-1811.
- (10) Pasternack, B. S., "Linear Estimation in the Analysis of Pulse Height Spectra," *Technometrisch*, Vol. 4.
- (11) Adams, F., and Dams, R., *Applied Gamma-Ray Spectrometry*, Pergamon Press, New York, NY, 1970.
- (12) "Tenth Scintillation and Semiconductor Counter Symposium," IEEE Trans. NS-13, No. 3, 1966.
- (13) Friedlander, G., Kennedy, J.W., Macias, E.S., and Miller, J.M., *Nuclear and Radiochemistry*, 3rd Edition, John Wiley and Sons, Inc., New York, NY, 1981.
- (14) "Applied Gamma-Ray Spectrometry," Crouthamel, C. E., ed., Pergamon Press, New York, NY.
- (15) Price, W. J., *Nuclear Radiation Detection*, McGraw-Hill Book Co., Inc., New York, NY, 1964.
- (16) Seigbahn, K., *Alpha-, Beta-, and Gamma-Ray Spectroscopy*, North Holland Publishing Co., Amsterdam, 1965.
- (17) Cohn, C. E., Bennett, E. F., and Yule, T. J., "Hardware and Software for Nuclear Spectroscopy on the Varian Data Machines 622/i Computer," ANL-7704, National Technical Information Service, U. S. Dept. of Commerce, 5285 Port Royal Rd., Springfield, VA.
- (18) Cross, J. R., Doub, J. A., and Stedman, J. M., "On-Line Data Reduction for Nuclear Analyzer," *Hewlett-Packard Journal*, Vol. 22, No. 7, March 1971, pp. 2-10.
- (19) Friedlander, G., Kennedy, J. W., Macias, E.S., and Miller, J.M., *Nuclear and Radiochemistry*, 3rd Edition, John Wiley and Sons, Inc., New York, NY, 1981, Chapter 9.
- (20) Overman, R. T., and Clark, H. M., *Radioisotope Techniques*, McGraw-Hill Book Co., Inc., New York, NY, 1960, pp. 98-130.
- (21) Jarrett, A. A., "Statistical Methods Used in the Measurement of Radioactivity," AECU-262, Clearing House for Federal Scientific and Technical Information, Springfield, VA.

- (22) Rider, P. R., *An Introduction to Modern Statistical Methods*, John Wiley and Sons, Inc., New York, NY, 1939.
- (23) Hoel, P. G., *Introduction to Mathematical Statistics*, 2nd ed., John Wiley and Sons, Inc., New York, NY, 1954.
- (24) Bevington, P. R., *Data Reduction and Error Analysis for the Physical Sciences*, McGraw-Hill, Inc., New York, NY, 1969.
- (25) Firestone, R.B., and Shirley, V.S., *Table of Isotopes*, 8th Edition, John Wiley & Sons, Inc., New York, NY, 1998.
- (26) Firestone, R.B., Baglin, C.M. (ed), and Chu, S.Y. F. (ed), *Table of Isotopes: 1999 Update*, 8th Edition, John Wiley & Sons, Inc., New York, NY, 1999.
- (27) R.R. Kinsey, et al., The NUDAT/PCNUDAT Program for Nuclear Data, paper submitted to the 9th International Symposium of Capture Gamma-Ray Spectroscopy and Related Topics, Budapest, Hungary, October 1996 (<http://www.nndc.bnl.gov/>).
- (28) C.L. Dunford and T.W. Burrows, Online Nuclear Data Service, Report IAEA-NDS-150 (NNDC Informal Report NNDC/ONL-95/10), Rev. 95/10 (1995), International Atomic Energy Agency, Vienna, Austria (<http://www.nndc.bnl.gov/>).
- (29) Heath, R.L., “Scintillation Spectrometry, Gamma-Ray Spectrum Catalogue,” U.S. Atomic Energy Commission Report IDO-16880, in 2 volumes, 1964 (<http://id.inel.gov/gamma/>).
- (30) Lund University data, WWW source is the NNDC On-Line Data Service from ENSDF. M.R. Bhat, Evaluated Nuclear Structure Data File (ENSDF), *Nuclear Data for Science and Technology*, p. 817, edited by S.M. Qaim (Springer-Verlag, Berlin, Germany, 1992) (<http://nucleardata.nuclear.lu.se>).
- (31) DeSoete, D., and Hoste, J., “Predicting Gamma Resolution,” *Nucleonics*, Vol. 20, No. 4, April 1962, pp. 72–76.
- (32) Biggers, R. E., Bell, J. T., Long, E. C., and Russ, O. W., “Mathematical Resolution of Complex Overlapping Spectra with Non-Linear Least Squares Computer Techniques,” ORNL-3834, National Technical Information Service, U. S. Dept. of Commerce, 5285 Port Royal Rd., Springfield, VA.
- (33) Dwyer, P. S., *Linear Computations*, John Wiley and Sons, Inc., New York, NY, 1951.
- (34) Overman, R. F., “Normalizing Gamma Spectra for Data Processing,” DP-751, Clearing House for Federal Scientific and Technical Information, U. S. Department of Commerce, Springfield, VA.
- (35) Ferguson, A. J., “A Program for the Analysis of Gamma Ray Scintillation Spectra Using the Method of Least Squares,” AECL-1398, Atomic Energy of Canada Limited (Scientific Document Distribution Office), Chalk River, Ontario, Canada, 1961.
- (36) Strickfaden, W. B., and Kloepper, R. M., “IBM 704 Programs for Unfolding Complex Gamma Ray Spectra,” LA-2461, Clearing House for Federal Scientific and Technical Information, U. S. Department of Commerce, Springfield, VA.
- (37) “Applications of Computers to Nuclear and Radiochemistry,” NAS-NS-3107, Clearing House for Federal Scientific and Technical Information, U. S. Department of Commerce, Springfield, VA.
- (38) Upgrading Environmental Radiation Data, Health Physics Society Committee Report, HPSR-1, Chapter 6, 1980.

ASTM International takes no position respecting the validity of any patent rights asserted in connection with any item mentioned in this standard. Users of this standard are expressly advised that determination of the validity of any such patent rights, and the risk of infringement of such rights, are entirely their own responsibility.

This standard is subject to revision at any time by the responsible technical committee and must be reviewed every five years and if not revised, either reapproved or withdrawn. Your comments are invited either for revision of this standard or for additional standards and should be addressed to ASTM International Headquarters. Your comments will receive careful consideration at a meeting of the responsible technical committee, which you may attend. If you feel that your comments have not received a fair hearing you should make your views known to the ASTM Committee on Standards, at the address shown below.

This standard is copyrighted by ASTM International, 100 Barr Harbor Drive, PO Box C700, West Conshohocken, PA 19428-2959, United States. Individual reprints (single or multiple copies) of this standard may be obtained by contacting ASTM at the above address or at 610-832-9585 (phone), 610-832-9555 (fax), or service@astm.org (e-mail); or through the ASTM website (www.astm.org). Permission rights to photocopy the standard may also be secured from the Copyright Clearance Center, 222 Rosewood Drive, Danvers, MA 01923, Tel: (978) 646-2600; <http://www.copyright.com/>