



# Standard Test Method for Flat Particles, Elongated Particles, or Flat and Elongated Particles in Coarse Aggregate<sup>1</sup>

This standard is issued under the fixed designation D4791; the number immediately following the designation indicates the year of original adoption or, in the case of revision, the year of last revision. A number in parentheses indicates the year of last reapproval. A superscript epsilon ( $\epsilon$ ) indicates an editorial change since the last revision or reapproval.

*This standard has been approved for use by agencies of the U.S. Department of Defense.*

## 1. Scope

1.1 This test method covers the determination of the percentages of flat particles, elongated particles, or flat and elongated particles in coarse aggregates. Two procedures, Method A and Method B, are presented in this standard. Method A is a reflection of the original procedure as developed prior to Superpave and is intended for all non-Superpave applications. Method B is a comparison of the maximum particle dimension to the minimum particle dimension and is intended for use with Superpave specifications.

1.2 The values stated in inch-pound units are to be regarded as standard. The values given in parentheses are mathematical conversions to SI units that are provided for information only and are not considered standard.

1.2.1 *Exception—(Regarding sieves, per Specification E11)* The values stated in SI units shall be considered standard for the dimensions of the wire cloth openings and the diameter of the wires used in the wire cloth. When sieve mesh sizes are referenced, the alternate inch-pound designations are provided for information purposes and enclosed in parenthesis.

1.3 *This standard does not purport to address all of the safety concerns, if any, associated with its use. It is the responsibility of the user of this standard to establish appropriate safety and health practices and determine the applicability of regulatory limitations prior to use.*

## 2. Referenced Documents

### 2.1 ASTM Standards:<sup>2</sup>

[C136 Test Method for Sieve Analysis of Fine and Coarse Aggregates](#)

[C670 Practice for Preparing Precision and Bias Statements for Test Methods for Construction Materials](#)

[C702 Practice for Reducing Samples of Aggregate to Testing Size](#)

[D75 Practice for Sampling Aggregates](#)

[E11 Specification for Woven Wire Test Sieve Cloth and Test Sieves](#)

## 3. Terminology

### 3.1 Definitions:

3.1.1 *elongated particles of aggregate*—those particles of aggregate having a ratio of length to width greater than a specified value.

3.1.2 *flat and elongated particles of aggregate*—those particles having a ratio of length to thickness greater than a specified value.

3.1.3 *flat particles of aggregate*—those particles of aggregate having a ratio of width to thickness greater than a specified value.

3.1.4 *length*—maximum dimension of the particle, as illustrated in [Fig. 1](#).

3.1.5 *thickness*—minimum dimension of particle. It is the maximum dimension perpendicular to the length and width as illustrated in [Fig. 1](#).

3.1.6 *width*—intermediate dimension of the particle. It is the maximum dimension in the plane perpendicular to the length and thickness. The width dimension is greater than or equal to the thickness as illustrated in [Fig. 1](#).

## 4. Summary of Test Method

4.1 Individual particles of aggregate of specific sieve sizes are measured to determine the ratios of width to thickness, length to width, or length to thickness.

## 5. Significance and Use

5.1 The particles shape of course aggregates influences the properties of some construction materials and may affect their placement and consolidation.

<sup>1</sup> This test method is under the jurisdiction of ASTM Committee D04 on Road and Paving Materials and is the direct responsibility of Subcommittee D04.51 on Aggregate Tests.

Current edition approved June 1, 2010. Published October 2010. Originally approved in 1989. Last previous edition approved in 2005 as D4791 – 05<sup>e1</sup>. DOI: 10.1520/D4791-10.

<sup>2</sup> For referenced ASTM standards, visit the ASTM website, [www.astm.org](http://www.astm.org), or contact ASTM Customer Service at [service@astm.org](mailto:service@astm.org). For *Annual Book of ASTM Standards* volume information, refer to the standard's Document Summary page on the ASTM website.

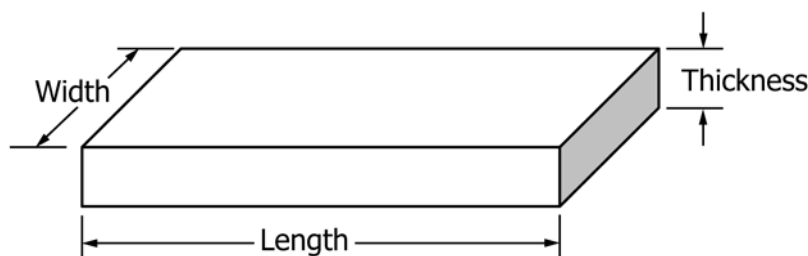

FIG. 1 Particle Dimensions

5.2 This test method provides a means for checking compliance with specifications that limit such particles or to determine the relative shape characteristics of coarse aggregates.

## 6. Apparatus

6.1 The apparatus used shall be equipment suitable for testing aggregate particles for compliance with the definitions in 3.1, at the dimensional ratios desired.

6.1.1 *Proportional Caliper Device*—The proportional caliper devices illustrated in Fig. 2 and Fig. 3 are examples of devices suitable for this test method. The device illustrated in Fig. 2 and consists of a base plate with two fixed posts and a swinging arm mounted between them so that the openings between the arms and the posts maintain a constant ratio. The axis position can be adjusted to provide the desired ratio of opening dimensions. Fig. 2 illustrates a device on which ratios of 1:2, 1:3, and 1:5 may be set. The device illustrated in Fig. 3 contains several fixed posts and has the capability of measuring various ratios simultaneously. See Note 1

6.1.1.1 *Verification of Ratio*—The ratio settings on the proportional caliper device shall be verified by the use of a machined block, micrometer, or other appropriate device.

6.1.2 *Balance*—The balance or scales used shall be accurate to 0.5 % of the mass of the sample.

NOTE 1—Figs. 2 and 3 provide examples of possible devices that may be used for this test. Other devices may be found suitable if they are able to meet the verification requirements listed in 6.1.1.1.

## 7. Sampling

7.1 Sample the coarse aggregate in accordance with Practice D75. The mass of the field sample shall be the mass shown in Practice D75.

7.2 Thoroughly mix the sample and reduce it to an amount suitable for testing using the applicable procedures described in Practice C702. The sample for test shall be approximately the mass desired when dry and shall be the end result of the reduction. Reduction to an exact predetermined mass shall not be permitted. The mass of the test sample shall conform to the following:

Nominal Maximum Size Square Openings, in. (mm)	Minimum Mass of Test Sample, lb (kg)
3/8 (9.5)	2 (1)
1/2 (12.5)	4 (2)
3/4 (19.0)	11 (5)
1 (25.0)	22 (10)
1 1/2 (37.5)	33 (15)
2 (50)	44 (20)
2 1/2 (63)	77 (35)
3 (75)	130 (60)
3 1/2 (90)	220 (100)
4 (100)	330 (150)
4 1/2 (112)	440 (200)
5 (125)	660 (300)
6 (150)	1100 (500)

## 8. Procedure

8.1 If determination by mass is required, oven dry the sample to constant mass at a temperature of  $230 \pm 9^\circ\text{F}$  ( $110 \pm 5^\circ\text{C}$ ). If determination is by particle count, drying is not necessary.

8.2 Sieve the sample to be tested in accordance with Test Method C136. Using the material retained on the 3/8 in. (9.5 mm) or No. 4 (4.75 mm), as required by the specification being used, reduce each size fraction present in the amount of 10 % or more of the original sample in accordance with Practice C702 until approximately 100 particles are obtained for each size fraction required. Size fractions containing less than 10 % by mass of the original total sample mass are not tested and can be discarded.

8.3 *Method A*—Test each of the particles in each size fraction, and place in one of four groups: (1) flat particles, (2) elongated particles, (3) particles that meet the criteria of both group (1) and group (2); (4) neither flat nor elongated particles that do not meet the criteria of either group (1) or group (2). Each particle shall be subjected to the Flat Particle Test and Elongated Particle Test in accordance with 8.3.1.1 and 8.3.1.2. If the particle is determined to be flat but not elongated, the particle is placed in the “flat” group. If it is determined that the particle is not flat, but is elongated, the particle is placed in the “elongated” group. In some cases it may be possible for a particle to meet the criteria of both a flat particle and an elongated particle. In this case the particle is placed in the

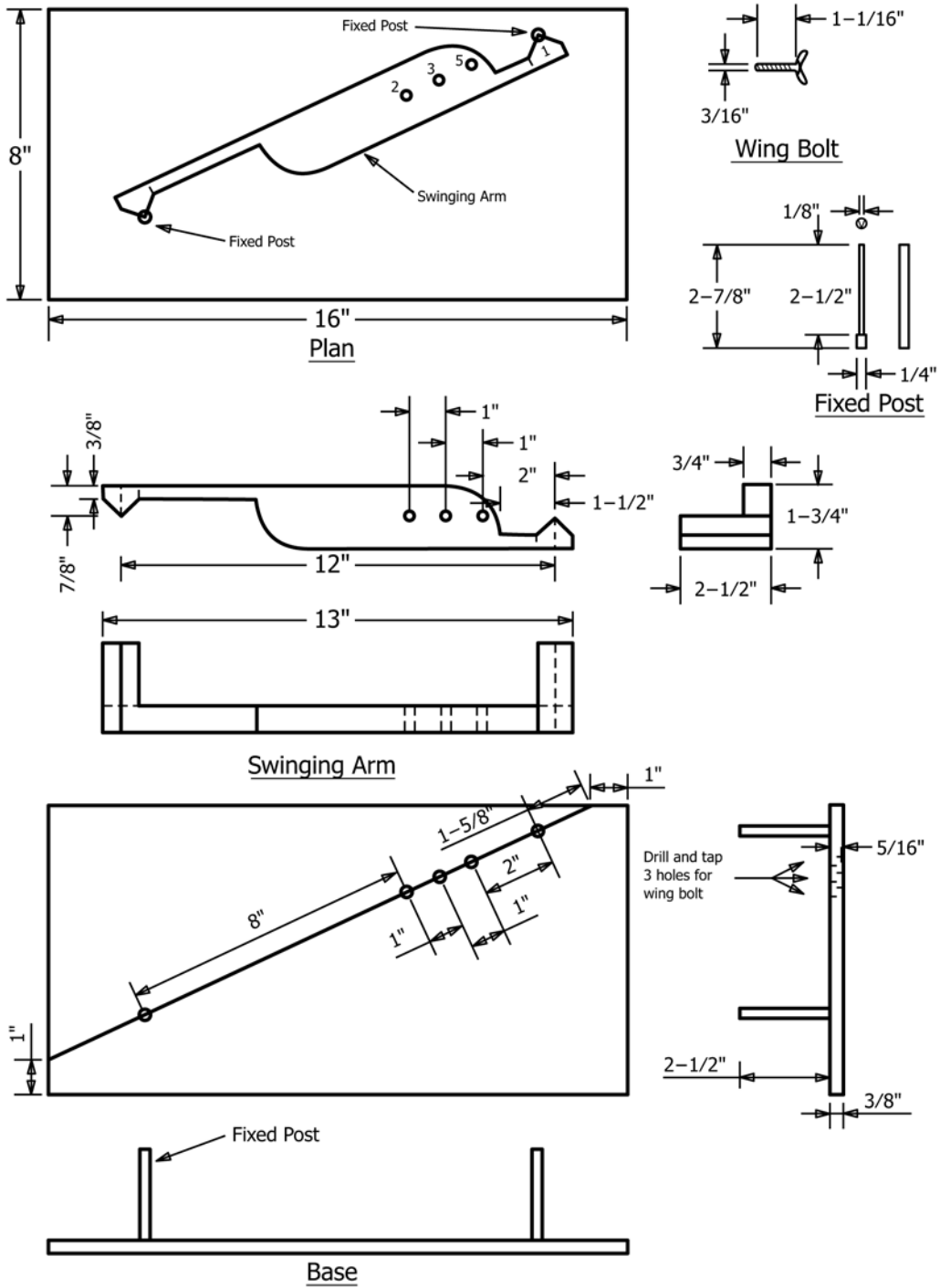

Metric Equivalents

in.	(mm)	in.	(mm)
1/8	(3.2)	1 5/8	(41.0)
3/16	(4.8)	1 3/4	(44.5)
1/4	(6.3)	2	(50.8)
5/16	(7.9)	2 1/2	(64.0)
3/8	(9.5)	2 7/8	(72.0)
3/4	(19.1)	3 3/4	(96.0)
7/8	(21.2)	8	(207.0)
1	(25.4)	12	(304.8)
1 1/16	(27.0)	13	(330.2)
1 1/2	(38.0)	16	(414.0)

FIG. 2 Proportional Caliper

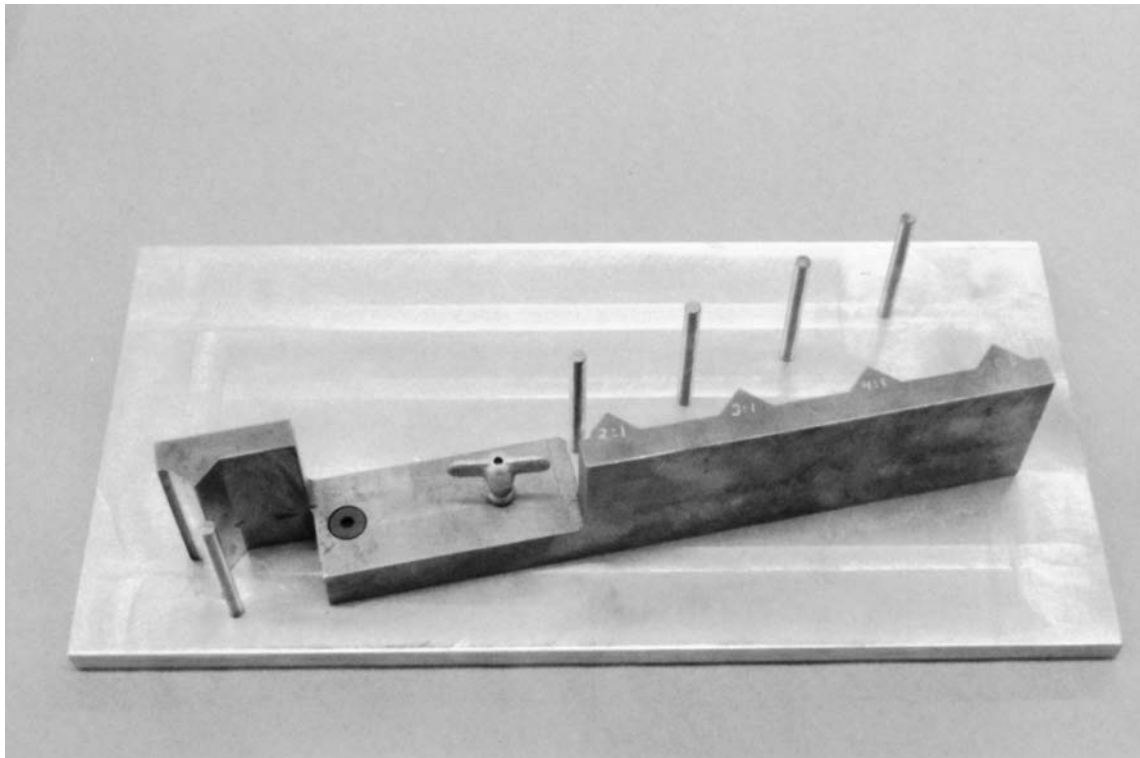

FIG. 3 Proportional Caliper

“particles that meet the criteria of both group (1) and group (2)” group. If the particle is not flat and is not elongated, it is placed in the “particles that do not meet the criteria of either group (1) or group (2)” group.

8.3.1 Use the proportional caliper device, positioned at the proper ratio, shown in Fig. 4, as follows:

8.3.1.1 *Flat Particle Test*—Set the larger opening equal to the maximum particle width. The particle is flat if the maximum thickness can be placed through the smaller opening.

8.3.1.2 *Elongated Particle Test*—Set the larger opening equal to the maximum particle length. The particle is elongated if the maximum width can be placed through the smaller opening.

8.3.2 After each of the particles have been classified into one of the groups described in 8.3, determine the proportion of the sample in each group by either count or by mass, as required.

8.4 *Method B*—Test each of the particles in each size fraction and place in one of two groups: (1) flat and elongated or (2) not flat and elongated.

8.4.1 Use the proportional caliper device, set at the desired ratio as shown in Fig. 4, as follows.

8.4.1.1 *Flat and Elongated Particle Test*—Set the larger opening equal to the maximum particle length. The particle is considered flat and elongated if the maximum thickness can be placed through the smaller opening.

8.4.2 After the particles have been classified into the groups described in 8.4, determine the proportion of the sample in each group by count or mass, as required.

## 9. Calculation

9.1 Calculate the percentage of particles in each group to the nearest 1 % for each size fraction tested greater than  $\frac{3}{8}$  in. (9.5 mm) or No. 4 (4.75 mm), as required.

## 10. Report

10.1 Include the following information in the report:

10.1.1 Identification of the coarse aggregate tested, and

10.1.2 Grading of the original aggregate sample, showing percentage retained on each sieve.

10.1.3 *For Method A:*

10.1.3.1 Number of particles in each sieve size tested,

10.1.3.2 Percentages, calculated by number or by mass, or both, for each group: (1) flat particles, (2) elongated particles, and (3) particles that meet the criteria of both group (1) and group (2); (4) particles that do not meet the criteria of either group (1) or group (2), and

10.1.3.3 The dimensional ratios used in the tests.

10.1.4 *For Method B:*

10.1.4.1 Number of particles in each sieve size tested,

10.1.4.2 Percentages, calculated by number or by mass, or both, for flat and elongated particles for each sieve size tested,

10.1.4.3 The dimensional ratio used in the tests, and

10.1.5 When required, weighted average percentages based on the actual or assumed proportions of the various sieve sizes tested. Report the grading used for the weighted average if different from that in 10.1.2.

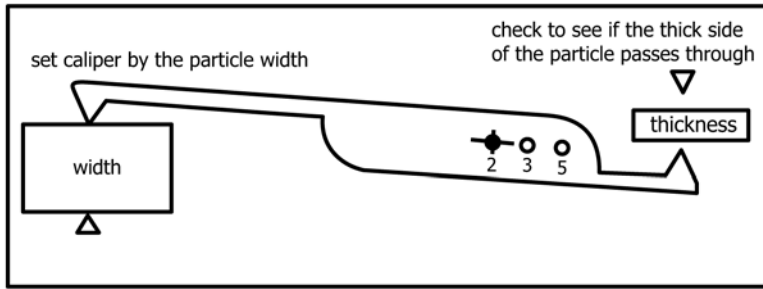

**flat particle test**

a. Test for flatness

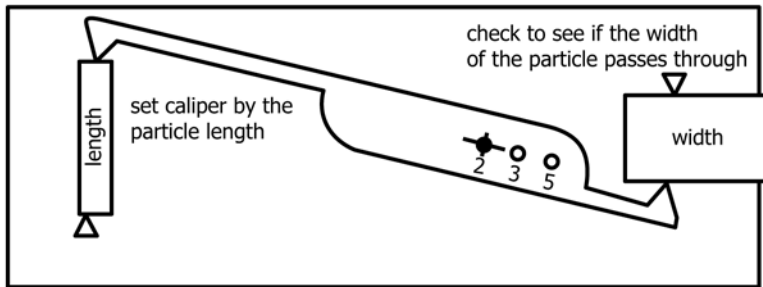

**elongated particle test**

b. Test for elongation

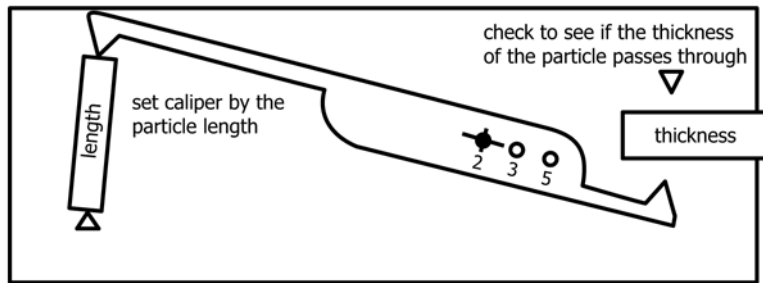

**flat and elongated particle test**

c. Test for elongation and flatness

**FIG. 4 Use of Proportional Caliper**

**11. Precision and Bias**

11.1 *Precision*—The precision values listed in Table 1, Table 2, and Table 3 are averages obtained from AMRL proficiency samples used in the Aggregate Proficiency Sample Program (see Note 2). The 1S % and D2S % limits provided are described in Practice C670.

NOTE 2—A 1:3 ratio was used.

11.2 *Bias*—Since there is no accepted reference material suitable for determining the bias for this test method, no statement on bias is being made.

**12. Keywords**

12.1 aggregates; coarse aggregates; particle shape

**TABLE 1 19.0-mm to 12.5-mm Flat and Elongated (Percent)**

Precision	Test Result (%)	(1S) %	(D2S) %
Single Operator	2.7	51.2	144.8
Multilaboratory		88.5	250.3

**TABLE 2 12.5-mm to 9.5-mm Flat and Elongated (Percent)**

Precision	Test Result (%)	(1S) %	(D2S) %
Single Operator	34.9	22.9	64.7
Multilaboratory		43.0	121.8

**TABLE 3 9.5-mm to 4.75-mm Flat and Elongated (Percent)**

Precision	Test Result (%)	(1S) %	(D2S) %
Single Operator	24.1	19.0	53.6
Multilaboratory		46.1	130.3†

†Value corrected

*ASTM International takes no position respecting the validity of any patent rights asserted in connection with any item mentioned in this standard. Users of this standard are expressly advised that determination of the validity of any such patent rights, and the risk of infringement of such rights, are entirely their own responsibility.*

*This standard is subject to revision at any time by the responsible technical committee and must be reviewed every five years and if not revised, either reapproved or withdrawn. Your comments are invited either for revision of this standard or for additional standards and should be addressed to ASTM International Headquarters. Your comments will receive careful consideration at a meeting of the responsible technical committee, which you may attend. If you feel that your comments have not received a fair hearing you should make your views known to the ASTM Committee on Standards, at the address shown below.*

*This standard is copyrighted by ASTM International, 100 Barr Harbor Drive, PO Box C700, West Conshohocken, PA 19428-2959, United States. Individual reprints (single or multiple copies) of this standard may be obtained by contacting ASTM at the above address or at 610-832-9585 (phone), 610-832-9555 (fax), or service@astm.org (e-mail); or through the ASTM website (www.astm.org). Permission rights to photocopy the standard may also be secured from the Copyright Clearance Center, 222 Rosewood Drive, Danvers, MA 01923, Tel: (978) 646-2600; <http://www.copyright.com/>*