



Standard Test Method for Stitch Tear Strength of Leather, Double Hole¹

This standard is issued under the fixed designation D4705; the number immediately following the designation indicates the year of original adoption or, in the case of revision, the year of last revision. A number in parentheses indicates the year of last reapproval. A superscript epsilon (ϵ) indicates an editorial change since the last revision or reapproval.

This standard has been approved for use by agencies of the U.S. Department of Defense.

1. Scope

1.1 This test method is intended for use in determining the stitch tearing resistance of leather using a double hole tear. It is particularly applicable to lightweight leathers. This test method does not apply to wet blue.

1.2 The values stated in inch-pound units are to be regarded as standard. The values given in parentheses are mathematical conversions to SI units that are provided for information only and are not considered standard.

1.3 *This standard does not purport to address all of the safety concerns, if any, associated with its use. It is the responsibility of the user of this standard to establish appropriate safety and health practices and determine the applicability of regulatory limitations prior to use.*

2. Referenced Documents

2.1 *ASTM Standards:*²

[D1610 Practice for Conditioning Leather and Leather Products for Testing](#)

[D1813 Test Method for Measuring Thickness of Leather Test Specimens](#)

[D2209 Test Method for Tensile Strength of Leather](#)

[D2813 Practice for Sampling Leather for Physical and Chemical Tests](#)

3. Significance and Use

3.1 This test method is designed to measure the load required to tear leather through two holes in the test specimen. Tanners and leather buyers have found that this test gives an indication of the resistance of leather to tearing. It is of particular value in estimating the durability of leather to withstand tearing stresses encountered in the manufacture of shoes, garments, and upholstered products. The thickness of

the specimen and direction of tear relative to the backbone will affect the uniformity of the test results. This test method may not apply when the conditions of the test employed differ widely from those specified in the test method.

4. Apparatus

4.1 *Testing Machine*, as described in Test Method [D2209](#).

4.2 *Thickness Gage*, a dead weight type of thickness gage as described in Method [D1813](#).

4.3 *Steel Die*, to cut test specimens (as described in [5.1](#)).

4.4 *Paper Clip*, #1/Premium, with wire diameter 0.041 ± 0.001 in. (1.04 ± 0.0254 mm).

5. Sampling Test Specimen

5.1 Unless otherwise specified, sample the leather according to Practice [D2813](#).

5.2 The specimen shall be a rectangle of leather 2 in. (50.8 mm) in length and 1 in. (25.4 mm) in width with two holes ($\frac{5}{64}$ in. (1.98 mm)) in diameter on one end of the specimen. The centers of the holes shall be $\frac{1}{4}$ in. (6.35 mm) from the end, $\frac{1}{4}$ in. (6.35 mm) apart, and located equidistant from the center line (length wise) of the specimen. See [Fig. 1](#).

5.3 The specimen shall be cut with the long dimension perpendicular to the backbone.

6. Conditioning

6.1 All specimen shall be conditioned and tested in an atmosphere as described in Practice [D1610](#).

7. Procedure

7.1 Determine the thickness of the specimen to the nearest 0.001 in. (0.01 mm) on the long axis near one end.

7.2 Bend the wire into a “U” shape, preferably by bending over a $\frac{1}{4}$ in. (6.35 mm) rod, and pass the ends through the holes in the specimen so that both ends project from the flesh side of the specimen. Clamp both ends of the wire in the testing machine grip, the jaws of which have been covered. Clamp the free end of the specimen in the other grip of the testing machine.

¹ This test method is under the jurisdiction of ASTM Committee [D31](#) on Leather and is the direct responsibility of Subcommittee [D31.07](#) on Physical Properties.

Current edition approved May 1, 2013. Published May 2013. Originally approved in 1987. Last previous edition approved in 2012 as D4705 - 12. DOI: 10.1520/D4705-13.

² For referenced ASTM standards, visit the ASTM website, www.astm.org, or contact ASTM Customer Service at service@astm.org. For *Annual Book of ASTM Standards* volume information, refer to the standard's Document Summary page on the ASTM website.

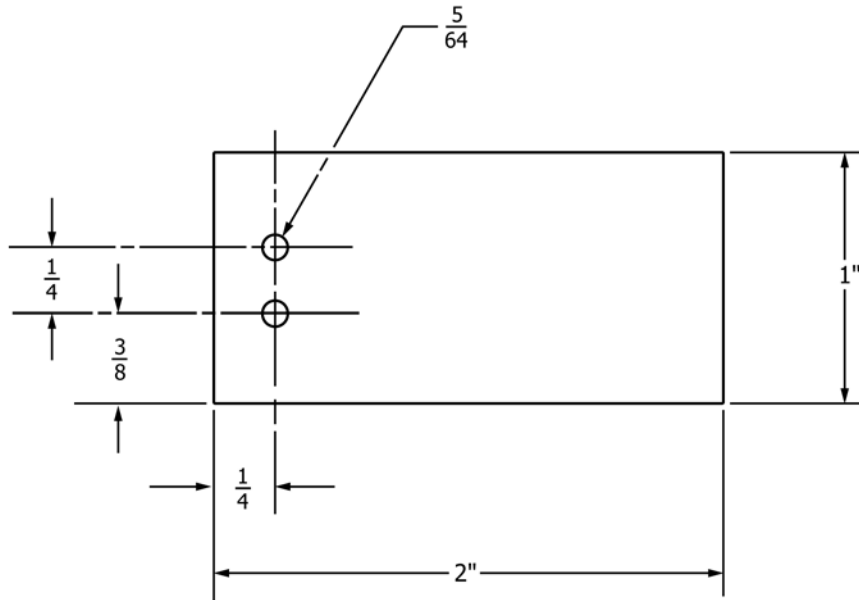

FIG. 1 Test Specimen

7.3 Operate the machine at 10 ± 2 in. (254 ± 50.8 mm) per minute until the specimen tears. At the instant that the specimen begins to tear, note and record the load registered by the machine.

8. Report

8.1 Report the following:

8.1.1 Thickness to the nearest 0.001 in. (0.01 mm) reported for each specimen or averaged and reported as the thickness of the sample.

8.1.2 The tearing strength of the specimen shall be reported to the nearest 1 lb (0.45 kg).

9. Precision and Bias (or Reproducibility)

9.1 This test method is adopted from the procedure of the American Leather Chemists Association where it has long been

in use and where it was approved for publication before the inclusion of precision and bias statements was mandated. The original interlaboratory test data is no longer available. The user is cautioned to verify by the use of reference materials, if available, that the precision and bias (or reproducibility) of this test method is adequate for the contemplated use.

10. Keywords

10.1 leather; stitch tear; stitch tear strength; strength; tear strength; tearing strength

ASTM International takes no position respecting the validity of any patent rights asserted in connection with any item mentioned in this standard. Users of this standard are expressly advised that determination of the validity of any such patent rights, and the risk of infringement of such rights, are entirely their own responsibility.

This standard is subject to revision at any time by the responsible technical committee and must be reviewed every five years and if not revised, either reapproved or withdrawn. Your comments are invited either for revision of this standard or for additional standards and should be addressed to ASTM International Headquarters. Your comments will receive careful consideration at a meeting of the responsible technical committee, which you may attend. If you feel that your comments have not received a fair hearing you should make your views known to the ASTM Committee on Standards, at the address shown below.

This standard is copyrighted by ASTM International, 100 Barr Harbor Drive, PO Box C700, West Conshohocken, PA 19428-2959, United States. Individual reprints (single or multiple copies) of this standard may be obtained by contacting ASTM at the above address or at 610-832-9585 (phone), 610-832-9555 (fax), or service@astm.org (e-mail); or through the ASTM website (www.astm.org). Permission rights to photocopy the standard may also be secured from the Copyright Clearance Center, 222 Rosewood Drive, Danvers, MA 01923, Tel: (978) 646-2600; http://www.copyright.com/