



Standard Test Method for Vibratory Packing Density of Large Formed Catalyst and Catalyst Carrier Particles¹

This standard is issued under the fixed designation D4699; the number immediately following the designation indicates the year of original adoption or, in the case of revision, the year of last revision. A number in parentheses indicates the year of last reapproval. A superscript epsilon (ϵ) indicates an editorial change since the last revision or reapproval.

1. Scope

1.1 This test method covers the determination of the vibratory packing density of formed catalyst and catalyst carrier particles that will not break up significantly under test conditions. For the purpose of this test, catalyst particles are defined as extrudates, spheres or formed pellets greater than 4.8 mm.

1.2 The values stated in SI units are to be regarded as standard. No other units of measurement are included in this standard.

1.3 *This standard does not purport to address all of the safety concerns, if any, associated with its use. It is the responsibility of the user of this standard to establish appropriate safety and health practices and determine the applicability of regulatory limitations prior to use.*

2. Referenced Documents

2.1 *ASTM Standards:*²

[D3766 Terminology Relating to Catalysts and Catalysis](#)

[E177 Practice for Use of the Terms Precision and Bias in ASTM Test Methods](#)

[E456 Terminology Relating to Quality and Statistics](#)

[E691 Practice for Conducting an Interlaboratory Study to Determine the Precision of a Test Method](#)

3. Terminology

3.1 *Definitions*—See Terminology [D3766](#).

4. Summary of Test Method

4.1 A known sample of environmentally equilibrated formed catalyst or catalyst carrier particles is vibrated in a graduated cylinder. The vibratory packing density is determined for a specified drying condition.

¹ This test method is under the jurisdiction of ASTM Committee [D32](#) on Catalysts and is the direct responsibility of Subcommittee [D32.02](#) on Physical-Mechanical Properties.

Current edition approved March 1, 2013. Published March 2013. Originally approved in 1987. Last previous edition approved in 2008 as D4699–03(2008). DOI: 10.1520/D4699-03R13.

² For referenced ASTM standards, visit the ASTM website, www.astm.org, or contact ASTM Customer Service at service@astm.org. For *Annual Book of ASTM Standards* volume information, refer to the standard's Document Summary page on the ASTM website.

5. Significance and Use

5.1 This test method is used for measuring the vibratory packing density of formed particles used in fixed bed reactors, driers, and so forth.

6. Apparatus

6.1 *Graduated Cylinder*, capacity 2000-mL.

6.2 *Vibratory Plate*.³

6.3 *Desiccator*, with a desiccant grade molecular sieve such as 4A.

6.4 *Balance*, having a sensitivity of 1.0 g.

6.5 *Balance*, having a sensitivity of 0.1 g.

6.6 *Drying Oven*.

7. Procedure

7.1 Equilibrate test sample to laboratory environment for 4 h.

7.2 Pour between 1000 to 2000 mL of the test specimen carefully into a tared beaker and weigh to the nearest 1 g. Record as W .

7.3 Separately weigh to the nearest tenth of a gram about 100 g of additional test sample, W_f , that will be used for moisture loss. Heat this sample at $400 \pm 15^\circ\text{C}$ for not less than 3 h. Normally, this treatment can take place in air; however, in the case of materials that might react with air at elevated temperature (such as prerduced catalysts) the heat treatment should take place in an inert atmosphere. After heating, cool the test sample in a desiccator or other suitable container to eliminate the possibility of moisture adsorption prior to weighing. Weigh the sample to the nearest tenth of a gram, W_H .

NOTE 1—The conditions may not be appropriate for all materials.

NOTE 2—Since many catalyst formulations are strong adsorbents, the use of a 4A indicating (cobalt-treated) molecular sieve as a desiccating

³ The sole source of supply of the Syntron Vibrating Machine, Model V-2-B with Power Pulse Controller, known to the committee at this time is FMC Technologies, 57 Cooper Ave., Homer City, PA 15748–9234. If you are aware of alternative suppliers, please provide this information to ASTM International Headquarters. Your comments will receive careful consideration at a meeting of the responsible technical committee¹, which you may attend.

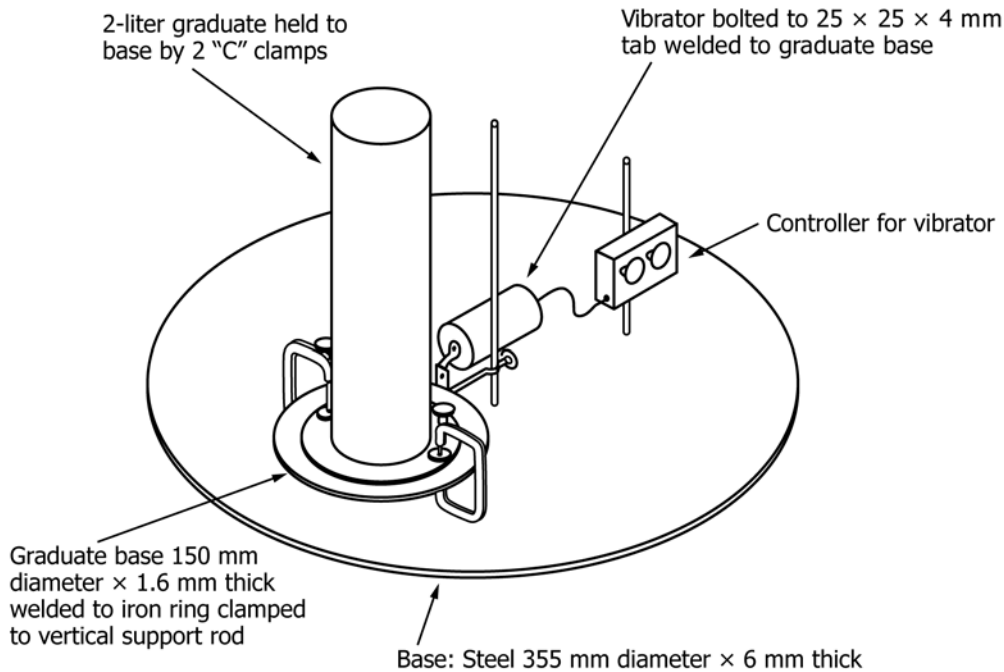

FIG. 1 Example of Components of Vibratory Stand for Large Diameter Pellets

medium is recommended. The desiccant should be regenerated at 220 to 260°C, as required.

NOTE 3—Multiple samples can be pretreated but must be desiccated prior to analysis.

7.4 Clamp the cylinder to the vibratory plate (see example Fig. 1).

7.5 Start vibrator at a setting at the midpoint of the rheostat range and pour the 1000 to 2000-mL test specimen carefully into the graduated cylinder using a funnel. The entire transfer time should be between 90 and 120 s. Those vibrating plate machines that operate at a frequency other than 60 Hz will require appropriate adjustment of the vibrating time.

7.6 Continue vibrating for 5 min.

7.7 When vibration is completed, read the packed volume, V , to the nearest 1 mL by estimating the average level of the catalyst surface in the cylinder.

8. Calculation

8.1 Calculate the moisture loss as follows:

$$L = (W_I - W_H) / W_I \quad (1)$$

where:

- L = mass fraction moisture loss,
- W_I = initial mass prior to drying, g, and
- W_H = mass after drying, g

8.2 Calculate the vibratory packing density as follows:

$$VPD = \frac{(1 - L)W}{V} \quad (2)$$

where:

- VPD = vibratory packing density, g/mL,
- W = mass of equilibrated catalyst particles, g, and

V = volume occupied by particles in measuring cylinder, mL.

8.3 Report the average of two or more runs.

9. Precision and Bias⁴

9.1 *Test Program*—An interlaboratory study was conducted in which the named property was measured in three separate test materials in four separate laboratories. Practice E691, modified for non-uniform data sets, was followed for the data reduction. Analysis details are in the research report.

9.2 *Precision*—Pairs of test results obtained by the procedure described in the method are expected to differ in absolute value by less than 2.772 S, where 2.772 S is the 95 % probability limit on the difference between two test results, and S is the appropriate estimate of standard deviation. Definitions and usage are given in Terminology E456 and Practice E177, respectively.

Test Result (Consensus Mean) g/mL	95 % Repeatability Limit (Within Laboratory), g/mL (% of mean)	95 % Reproducibility Limit (Between Laboratories) g/mL (% of mean)
1.308	0.029 (2.2)	0.093 (7.1)
0.998	0.004 (0.4)	0.058 (5.8)
0.829	0.011 (1.3)	0.091 (11.0)

9.3 *Bias*—The procedure described for measuring vibratory packing density has no bias because the value of the vibratory packing density can be defined only in terms of the test methods.

⁴ Supporting data have been filed at ASTM International Headquarters and may be obtained by requesting Research Report RR:D32-1022.

10. Keywords

10.1 catalyst; large; packing density; vibratory

ASTM International takes no position respecting the validity of any patent rights asserted in connection with any item mentioned in this standard. Users of this standard are expressly advised that determination of the validity of any such patent rights, and the risk of infringement of such rights, are entirely their own responsibility.

This standard is subject to revision at any time by the responsible technical committee and must be reviewed every five years and if not revised, either reapproved or withdrawn. Your comments are invited either for revision of this standard or for additional standards and should be addressed to ASTM International Headquarters. Your comments will receive careful consideration at a meeting of the responsible technical committee, which you may attend. If you feel that your comments have not received a fair hearing you should make your views known to the ASTM Committee on Standards, at the address shown below.

This standard is copyrighted by ASTM International, 100 Barr Harbor Drive, PO Box C700, West Conshohocken, PA 19428-2959, United States. Individual reprints (single or multiple copies) of this standard may be obtained by contacting ASTM at the above address or at 610-832-9585 (phone), 610-832-9555 (fax), or service@astm.org (e-mail); or through the ASTM website (www.astm.org). Permission rights to photocopy the standard may also be secured from the Copyright Clearance Center, 222 Rosewood Drive, Danvers, MA 01923, Tel: (978) 646-2600; <http://www.copyright.com/>