



Standard Test Method for Determining In Situ Creep Characteristics of Rock¹

This standard is issued under the fixed designation D4553; the number immediately following the designation indicates the year of original adoption or, in the case of revision, the year of last revision. A number in parentheses indicates the year of last reappraisal. A superscript epsilon (ϵ) indicates an editorial change since the last revision or reappraisal.

1. Scope*

1.1 This test method covers the preparation, equipment, test procedure, and data documentation for determining in situ creep characteristics of a rock mass using a rigid plate subjected to controlled loading.

1.2 This test method is designed to be conducted in an underground opening; however, with suitable modifications, this test could be conducted at the surface.

1.3 The test is usually conducted parallel or perpendicular to the anticipated axis of thrust, as dictated by the design load or other orientations, based upon the application.

1.4 Flexible plate apparatus can be used if the anticipated creep displacement is within the tolerance of the travel of the flat jacks.

1.5 The values stated in inch-pound units are to be regarded as standard. The values given in parentheses are mathematical conversions to SI units that are provided for information only and are not considered standard.

1.6 *This standard does not purport to address all of the safety concerns, if any, associated with its use. It is the responsibility of the user of this standard to establish appropriate safety and health practices and determine the applicability of regulatory limitations prior to use.* For specific precaution statements, see Section 8.

2. Referenced Documents

2.1 *ASTM Standards:*²

D653 Terminology Relating to Soil, Rock, and Contained Fluids

D3740 Practice for Minimum Requirements for Agencies Engaged in Testing and/or Inspection of Soil and Rock as Used in Engineering Design and Construction

D4394 Test Method for Determining In Situ Modulus of

Deformation of Rock Mass Using Rigid Plate Loading Method
D4403 Practice for Extensometers Used in Rock

3. Terminology

3.1 *Definitions*—See Terminology D653 for general definitions.

3.2 *Definitions of Terms Specific to This Standard:*

3.2.1 *creep*—a time-dependent displacement of a plate pushed into the surface of the rock by a constant normal load. It is not directly related with laboratory creep data because of the nonuniformity of stress within the rock mass underneath the plate.

3.2.2 *displacement*—movement of the rigid plate, grout pad, or rock in response to and in the same direction as the applied load.

3.2.3 *load*—total force acting on the rock face.

3.2.4 *rigid plate*—plate with a deflection of less than 0.0005 in. (0.0125 mm) from the center to the edge of the plate when maximum load is applied.

4. Summary of Test Method

4.1 Areas on two opposing faces of a test opening are flattened, smoothed, and made parallel.

4.2 A grout pad and rigid metal plate are installed against each face and a hydraulic loading system is placed between the rigid plates.

4.3 The two faces are rapidly loaded to the desired creep load, without shock, the load maintained, and the displacement of the plate measured as a function of time.

5. Significance and Use

5.1 Results of this test method are used to predict time-dependent deformation characteristics of a rock mass resulting from loading. It is a test that may be required depending on rock type or anticipated loads, or both.

5.2 This test method may be useful in structural design analysis where loading is applied over an extensive period.

5.3 This test method is normally performed at ambient temperature, but equipment can be modified or substituted for operations at other temperatures.

¹ This test method is under the jurisdiction of ASTM Committee D18 on Soil and Rock and is the direct responsibility of Subcommittee D18.12 on Rock Mechanics.

Current edition approved July 1, 2008. Published July 2008. Originally approved in 1985. Last previous edition approved in 2006 as D4553 – 02 (2006). DOI: 10.1520/D4553-08.

² For referenced ASTM standards, visit the ASTM website, www.astm.org, or contact ASTM Customer Service at service@astm.org. For *Annual Book of ASTM Standards* volume information, refer to the standard's Document Summary page on the ASTM website.

5.4 Results of this test method may be useful in verifying laboratory creep data and structural mathematical modeling analyses.

5.5 Creep characteristics are determined under a nonuniform state of stress.

5.6 If during a field investigation, time-dependent characteristics are detected, then an in situ creep test shall be performed.

NOTE 1—The quality of the result produced by this standard is dependent on the competence of the personnel performing it, and the suitability of the equipment and facilities used. Agencies that meet the criteria of Practice D3740 are generally considered capable of competent and objective testing/sampling/inspection/etc. Users of this standard are cautioned that compliance with Practice D3740 does not in itself assure reliable results. Reliable results depend on many factors; Practice D3740 provides a means of evaluating some of those factors.

6. Interferences

6.1 A completely inflexible plate used to load the rock face is difficult to construct. However, if the plate is constructed as rigid as feasible, the rock face is smoothed, and a thin, high-modulus material is used for the pad, the error in the measured displacements will be minimal.

6.2 The rock under the loaded area is generally not homogeneous, as assumed in theory. The rock will respond to the load according to its local deformational characteristics and orientation of discontinuities. The use of the average plate displacement will mitigate this problem. If this creep test is performed immediately after a plate loading test, the results of the creep test will be different than if it had been performed on virgin rock.

7. Apparatus

7.1 *Surface Preparation Equipment*— Test-site preparation equipment should include an assortment of excavation tools, such as drills and chipping hammers. Blasting shall not be allowed during final preparation of the test site.

7.2 Instrumentation:

7.2.1 *Displacement Measuring Equipment*— For displacement measurements, dial gauges or linear variable differential transformers (LVDTs) are generally used. A sensitivity of at least ± 0.0001 in. (± 0.0025 mm), including the error of the readout equipment, and an accuracy of at least 0.0005 in. (0.0125 mm) are required. Errors in excess of 0.0004 in. (0.01 mm) can invalidate test results when the modulus of rock mass exceeds 5×10^6 psi (3.5×10^4 MPa).

7.2.2 *Load Cell*—A load cell is recommended to measure the load on the bearing plate. An accuracy of ± 1000 lbf (4.4 kN) or ± 5 % of maximum test load, including errors introduced by the readout system, and a sensitivity of at least 500 lbf (2.2 kN) are reasonable. Long-term stability of the instrumentation system shall be verified throughout the test.

7.3 Loading Equipment:

7.3.1 *Hydraulic Ram or Flat Jacks*—This equipment, capable of applying and maintaining desired pressures to within ± 3 %, is usually used to apply the load. A spherical bearing of suitable capacity shall be coupled to one of the bearing plates. If a hydraulic ram is used, the load shall be corrected to

account for the effects of ram friction. If flat jacks are used, the jacks shall not be expanded beyond a thickness equal to 3 % of the diameter of a metal jack.

7.3.2 The loading equipment includes a device for applying the load and the reaction members, usually thick-walled aluminum or steel pipes, to transmit the load.

7.3.3 *Load Maintaining Equipment*—Equipment such as a servo-control system or air over hydraulic oil is required.

7.3.4 *Bearing Pads*—The bearing pads shall have a modulus of elasticity of at least 4×10^6 psi (3×10^4 MPa) (30 GPa) and shall be capable of conforming to the rock surface and bearing plate. High early strength grout or molten sulfur bearing pads are recommended.

7.3.5 *Bearing Plates*—The bearing plates shall approximate a rigid die as closely as practical. A bearing plate that has been found satisfactory is shown in Fig. 1. Although the exact design and materials may differ, the stiffness of the bearing plate shall be at least the minimum stiffness necessary to produce no measurable deflection of the plate under maximum load.

8. Precautions

8.1 All equipment and apparatus shall comply with the performance specifications in Section 7 and apparatus shall be verified. If no requirements are stated in Section 7, the manufacturer's specifications for the equipment may be appropriate as a guide to assure acceptable performance. Performance verification is generally done by calibrating the equipment and measurement system (see Fig. 2).

8.2 Enforce safety by applicable safety standards. Pressure lines must be bled of air to preclude violent failure of the pressure system.

9. In Situ Conditions

9.1 Areas that are geologically representative of the mass shall be selected. The plates shall be contained in the same geologic member. The testing program shall be designed so that effects of local geology can be clearly distinguished and the impact of excavation minimized.

9.2 The size of the bearing plate will be determined by the local geology, pressures to be applied, and the size of the opening in which the test is to be performed. These parameters shall be considered prior to excavation of the opening. Optimum opening dimensions are approximately six times the plate diameter. Recommended plate diameter is commonly 1 1/2 to 3 1/2 ft (0.5 to 1 m). Other plate sizes may be used depending upon site specifics.

9.3 The effects of anisotropy shall be investigated by appropriately oriented tests; for example, parallel and perpendicular to the long axes of columns in a basalt flow.

9.4 Tests shall be performed at a site not affected by structural changes resulting from excavations of the opening. The zone of rock that contributes to the measured displacement during loading depends on the diameter of the plate and the applied load. Larger plates and higher loads measure the response of rock farther away from the test opening. Thus, if the rock around the opening is damaged by the excavation process and the creep properties of the damaged zone are the

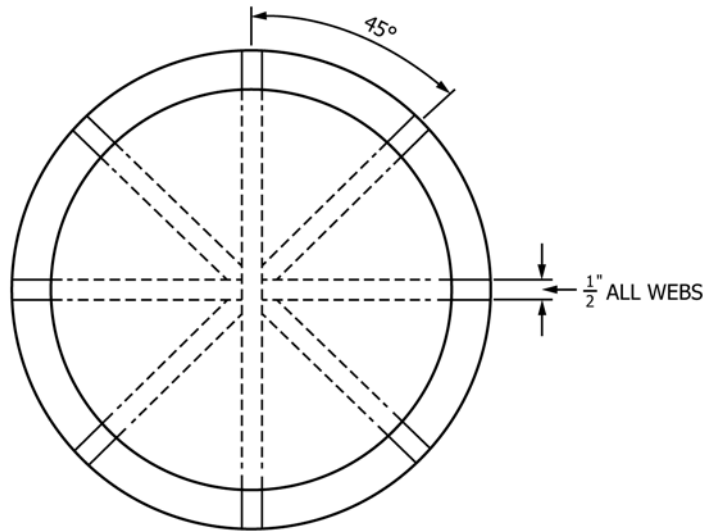

NOTE: ALL JOINTS FULLY WELDED

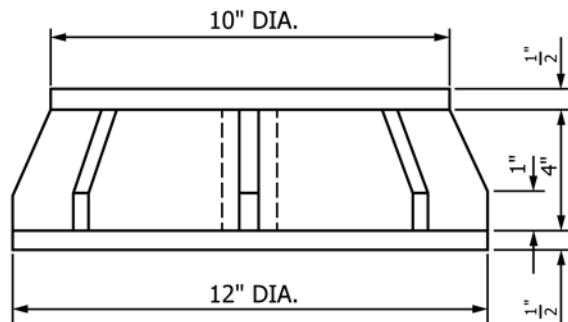

FIG. 1 Rigid Bearing Plate for 12 in. Diameter Test

primary objective of the test program, small-diameter plate tests on typically excavated surfaces are adequate.

9.5 Site conditions may dictate that site preparation and pad construction be performed immediately after excavation.

10. Procedure

10.1 A schematic of an optimum test setup is shown in Fig. 3. A properly located platform (not shown) allows for alignment of all test components.

10.2 Conduct the test across a “diameter” or chord of the opening with the two test surfaces nearly parallel and in planes oriented perpendicular to the thrust of the loading assembly.

10.3 Surface Preparation:

10.3.1 *Method*—Prepare the surface by a method that causes minimal damage to the finished rock surface. In the initial preparation of the finished test surface, many short drill holes may be required to remove unsound rock. Any residual rock between the drill holes may be removed by burnishing or moving the bit back and forth until a smooth face is achieved. Alternatively, in hard, competent rock, controlled blasting with

very small charges may be required to remove the unwanted materials. In weaker materials, coarse grinding or cutting devices may be used.

10.3.2 *Size*—The prepared rock surface shall extend at least one-half the diameter of the bearing plate beyond the edge of the plate.

10.3.3 *Rock Quality*—To the extent possible, prepare the bearing surface in sound rock. Remove loose and broken rock from the excavation. Deeper breaks may be detected by a dull hollow sound when the rock surface is struck with a hammer; remove such material.

10.3.4 *Smoothness*—The prepared rock face shall be as smooth as practicable. In no case shall the deviation from a plane between the highest and lowest points exceed 1 in. (25 mm).

10.3.5 *Cleaning*—After the surface has been prepared, scrub and rinse it with clean water to remove any loose particles or dirt caused by the smoothing operation.

10.4 *Bearing Pad Construction*—Construct the bearing pad, with the bearing plate in position, by pouring the pad material between the rock surface and the plate. Contain the pad

Project _____
 Feature _____
 Test location _____
 Orientation _____

Test No. _____
 Rock type _____
 Plate diameter _____
 Tested by _____

Sustain Load _____

Equipment description	Serial no.	Date of next calibration
_____	_____	_____
_____	_____	_____
_____	_____	_____
_____	_____	_____
_____	_____	_____
_____	_____	_____
_____	_____	_____
_____	_____	_____

Time	Load	Temperature	Plate displacement		
			No. 1	No. 2	No. 3
_____	_____	_____	_____	_____	_____
_____	_____	_____	_____	_____	_____
_____	_____	_____	_____	_____	_____
_____	_____	_____	_____	_____	_____
_____	_____	_____	_____	_____	_____
_____	_____	_____	_____	_____	_____
_____	_____	_____	_____	_____	_____
_____	_____	_____	_____	_____	_____
_____	_____	_____	_____	_____	_____

Remarks:

Test Supervisor _____ Date _____ Project Engineer _____ Date _____

FIG. 2 In Situ Creep Test Data Sheet

material by suitable form work around the edges of the plate. The only exception to this method is for near vertical tests where grout pads are used. In this case, the lower bearing plate may be placed directly upon the pad prior to curing. In all cases, exercise care to avoid air pockets or other cavities within the pad. The thickness of the pad shall be no more than 15 % of the plate diameter at any point. The dimensional requirements are shown in Fig. 4.

10.5 *Displacement Measuring Points*— Measure the displacement of the bearing plate in at least three locations equally spaced around the plate. Support the displacement transducers so that only the displacement of the plate is measured.

Generally, this means mounting the transducers from supports located outside the zone of influence of the test. In no case shall the transducers be mounted on the loading apparatus. Cross opening measurement points and equipment such as described in Practice D4403 may be installed if desired.

10.6 *Pretest Check*—After the loading and restraining components are installed, make a final check of all mechanical, hydraulic, and electronic components after the grout pads are placed and again before the load is applied.

10.7 *Pressurization (Loading)*:

10.7.1 Zero all measuring equipment.

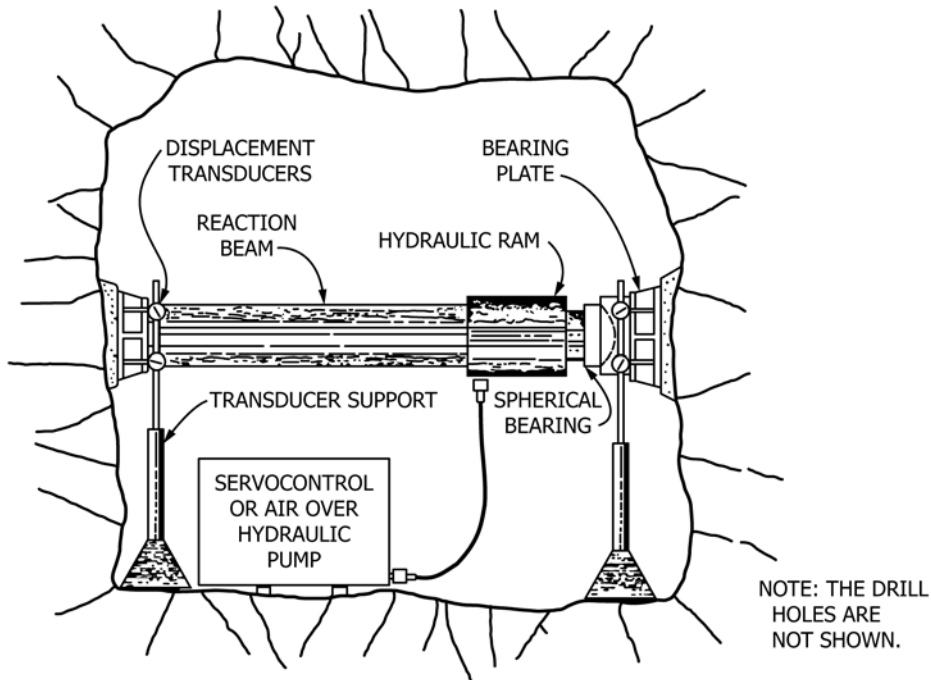

FIG. 3 Typical Rigid Plate Bearing Test Setup Schematic

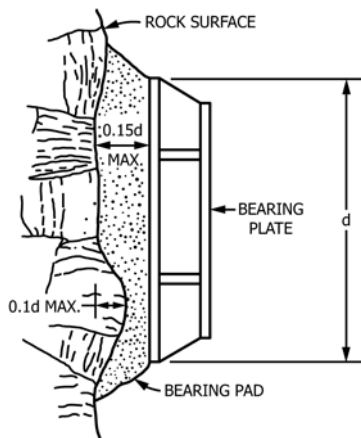

FIG. 4 Allowable Dimensions for Rock Surface and Bearing Pad

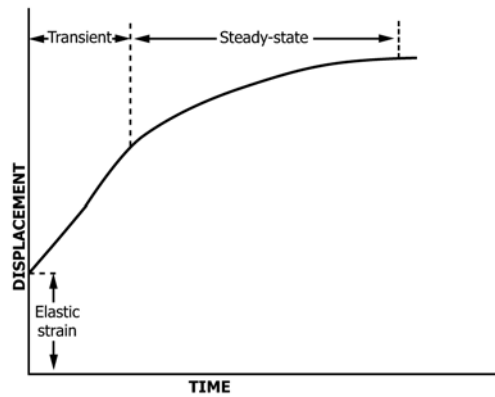

FIG. 5 Typical Creep Curve

10.7.2 Rapidly raise the load without shock, to the required test load. This is normally done within 1 min.

10.7.3 Record the displacement transducer reading immediately after the required test load has been applied. Thereafter, record displacements at suitable time intervals. During the transient creep period (Fig. 5), take displacement readings every few minutes to few hours until the displacement rate becomes constant. Readings shall then be taken daily or at a frequency designated by the engineer.

10.7.4 Record the load and ambient temperature at the times of the readings, as a minimum.

10.8 *Data*—Record the data shown on the example form in Fig. 2 as a minimum for each test.

11. Calculation

11.1 The displacement for each time interval is determined by averaging the three plate displacement readings recorded on the form in Fig. 2.

11.2 The average displacements are then plotted versus time, as shown in Fig. 5. It may be necessary to use a logarithmic scale for “time” if a long test period is involved.

12. Report

12.1 The purpose of this section is to establish the minimum requirements for a complete and usable report. Further details may be added as appropriate, and the order of items may be changed as necessary. Applications of the test results are beyond the scope of this test method, but may be an integral

part of some testing programs. In that case, an applications section compatible with the format described below shall be included.

12.2 Introductory Section of the Report—The introductory section is intended to present the scope and purpose of the testing program and the characteristics of the material tested, as follows:

12.2.1 Scope of Testing Program.

12.2.2 Test Locations—Present the location and orientation of the test equipment; a graphic presentation is recommended.

12.2.3 Test Rationale—Discuss the reasons for selecting the test locations.

12.2.4 Limitations of the Testing Program—Discuss in general terms the areas of interest which are not covered by the testing program and the limitations of the data within the areas of application.

12.2.5 Description of Test Site Geology—Include a complete geologic description of the test site including: core logs, photographs of core, photographs of prepared test areas, and a description of local blast damage. Describe the rock types macroscopically. Also describe structural features affecting the test. Diagrams of the geology of the test area, both before and after testing, are recommended.

12.3 Test Method:

12.3.1 Equipment and Apparatus—Include in the report a detailed listing of the equipment actually used for the test, including the name, model number, and basic specifications of each major piece.

12.3.2 Procedure—List in detailed steps the procedure actually used for the test.

12.3.3 Variations—If the actual equipment or procedure varies from the requirements contained in this test method, note each variation and the reasons for the variation. Discuss the effect of the variation upon the test results.

12.4 Theoretical Background:

12.4.1 Data Reduction Equations—Clearly present and fully define any equations used to reduce the data. Note any assumptions inherent in the equations or limitations in their applications and the effect on the results discussed.

12.4.2 Site-Specific Influences:

12.4.2.1 Assumptions—Discuss in detail the differences between the actual test site conditions and the conditions assumed in the data reduction equations. Estimate, as much as feasible, the effects of such differences on numerical results.

12.4.2.2 Correction Factors—Fully explain any factors or methods applied to the data to correct for a nonideal situation.

12.5 Results:

12.5.1 Table of Field Data—Present a summary table including the characteristics of the rock materials, the sustained loads at which the tests were performed, displacement record with time, and uncertainties.

12.5.2 Graphic Presentation—Present a typical displacement – time curve for each sustained load or rock type, or both.

12.5.3 Others—The following other types of analyses and presentations may be included as appropriate:

12.5.3.1 Relationship of creep and applied stress.

12.5.3.2 Relationship of creep dependence on geology.

12.5.3.3 Comparison with laboratory creep or the results of other in situ creep tests.

12.5.3.4 Comparison of results to other rock types or previous studies.

13. Precision and Bias

13.1 Precision—Due to the nature of rock materials tested by this test method, it is, at this time, either not feasible or too costly to produce multiple specimens that have uniform physical properties. Therefore, since specimens that would yield the same test results cannot be tested, Subcommittee D18.12 cannot determine the variation between tests since any variation observed is just as likely to be due to specimen variation as to operator or laboratory testing variation. Subcommittee D18.12 welcomes proposals to resolve this problem that would allow for development of a valid precision statement.

13.2 Bias—There is no accepted reference value for this test method; therefore, bias cannot be determined.

14. Keywords

14.1 creep; deformation; in situ stress; loading tests; rigid plate loading method

SUMMARY OF CHANGES

Committee D18 has identified the location of selected changes to this standard since the last issue (D4553 – 02 (2006)) that may impact the use of this standard. (Approved July 1, 2008.)

(1) Edited Section 1.5.

ASTM International takes no position respecting the validity of any patent rights asserted in connection with any item mentioned in this standard. Users of this standard are expressly advised that determination of the validity of any such patent rights, and the risk of infringement of such rights, are entirely their own responsibility.

This standard is subject to revision at any time by the responsible technical committee and must be reviewed every five years and if not revised, either reapproved or withdrawn. Your comments are invited either for revision of this standard or for additional standards and should be addressed to ASTM International Headquarters. Your comments will receive careful consideration at a meeting of the responsible technical committee, which you may attend. If you feel that your comments have not received a fair hearing you should make your views known to the ASTM Committee on Standards, at the address shown below.

This standard is copyrighted by ASTM International, 100 Barr Harbor Drive, PO Box C700, West Conshohocken, PA 19428-2959, United States. Individual reprints (single or multiple copies) of this standard may be obtained by contacting ASTM at the above address or at 610-832-9585 (phone), 610-832-9555 (fax), or service@astm.org (e-mail); or through the ASTM website (www.astm.org). Permission rights to photocopy the standard may also be secured from the Copyright Clearance Center, 222 Rosewood Drive, Danvers, MA 01923, Tel: (978) 646-2600; <http://www.copyright.com/>