



Standard Practice for Determining Water Injectivity Through the Use of On-Site Floods¹

This standard is issued under the fixed designation D4520; the number immediately following the designation indicates the year of original adoption or, in the case of revision, the year of last revision. A number in parentheses indicates the year of last reapproval. A superscript epsilon (ϵ) indicates an editorial change since the last revision or reapproval.

1. Scope*

1.1 This practice covers a procedure for conducting on-site core flood tests to determine the filtration and chemical treatment requirements for subsurface injection of water.^{2, 3}

1.2 This practice applies to water disposal, secondary recovery, and enhanced oil recovery projects and is applicable to injection waters with all ranges of total dissolved solids contents.

1.3 The values stated in SI units are to be regarded separately as standard. The values stated in each system are mathematical conversions and may not be exact equivalents; therefore, each system shall be used independently of the other.

1.4 *This standard does not purport to address all of the safety concerns, if any, associated with its use. It is the responsibility of the user of this standard to establish appropriate safety and health practices and determine the applicability of regulatory limitations prior to use.*

2. Referenced Documents

2.1 *ASTM Standards:*⁴

[D420 Guide to Site Characterization for Engineering Design and Construction Purposes](#) (Withdrawn 2011)⁵

[D653 Terminology Relating to Soil, Rock, and Contained Fluids](#)

[D1129 Terminology Relating to Water](#)

[D2434 Test Method for Permeability of Granular Soils \(Constant Head\)](#)

[D4404 Test Method for Determination of Pore Volume and Pore Volume Distribution of Soil and Rock by Mercury Intrusion Porosimetry](#)

2.2 *American Petroleum Institute Standards:*⁶

[API RP27 Recommended Practice for Determining Permeability of Porous Media](#)

[API RP40 Recommended Practice for Core-Analysis Procedure](#)

3. Terminology

3.1 *Definitions:*

3.1.1 For definitions of terms relating to water and water chemistry, refer to Terminology [D1129](#). Refer to Terminology [D653](#) for definitions relating to soil and rock

3.2 *Definitions of Terms Specific to This Standard:*

3.2.1 *filtration requirement, n*—the maximum suspended solids size (in micrometres) allowed in an injection water to minimize formation plugging.

3.2.2 *test core, n*—a sample cut from a full-core that has been recovered from the formation into which water is injected.

3.2.3 *permeability, n*—the capacity of a rock (or other porous medium) to conduct liquid or gas; permeability is measured as the proportionality constant between flow velocity and hydraulic gradient.

3.2.4 *pore volume, n*—the porous medium's void-volume that can be saturated with the transmitted fluid.

3.2.5 *porosity, n*—the ratio (usually expressed as a percentage) of the volume of voids of a given soil, rock mass, or other porous medium to the total volume of the soil, rock mass, or other porous medium.

3.2.6 *rock-water interaction, n*—a reaction between a porous rock and the injected water causing precipitation or swelling or release of fines (clays) within the rock.

4. Summary of Practice

4.1 This practice assumes that the injection water has been characterized in terms of dissolved and suspended solids

¹ This practice is under the jurisdiction of ASTM Committee [D19](#) on Water and is the direct responsibility of Subcommittee [D19.05](#) on Inorganic Constituents in Water.

Current edition approved Jan. 1, 2013. Published February 2013. Originally approved in 1986. Last previous edition approved in 2008 as D4520 – 03(2008). DOI: 10.1520/D4520-13.

² Farley, J. T., and Redline, D. G., "Evaluation of Flood Water Quality in the West Montalvo Field," *Journal Petroleum Technology*, July 1968, pp. 683–687.

³ McCune, C. C., "On-Site Testing to Define Injection Water Quality Requirements," *Journal Petroleum Technology*, January 1977, pp. 17–24.

⁴ For referenced ASTM standards, visit the ASTM website, www.astm.org, or contact ASTM Customer Service at service@astm.org. For *Annual Book of ASTM Standards* volume information, refer to the standard's Document Summary page on the ASTM website.

⁵ The last approved version of this historical standard is referenced on www.astm.org.

⁶ Available from American Petroleum Institute (API), 1220 L. St., NW, Washington, DC 20005-4070, <http://www.api.org>.

*A Summary of Changes section appears at the end of this standard

contents (including hydrocarbons and other organics as applicable) by established standard practices and methods.

4.2 Test core material is selected by consultation between geologists and engineers and prepared for the tests by standard practices.

4.3 In the on-site core flood the permeability of the test core is monitored to detect interactions between the formation rock and the injection water. The water is filtered at various levels to determine the filtration required (in micrometres) to minimize permeability loss (damage) from suspended solids. Backflowing injection wells are simulated by reversing the flow direction through the cores.

5. Significance and Use

5.1 The injectivity of a water is best determined by measurements as near to the well as possible to minimize changes in water properties due to air contact and time. This practice describes how core flow tests are carried out near the well.

5.2 This practice permits the differentiation of permeability losses from the effects of chemical interaction of water and rock and from the effects of plugging by suspended solids. The procedure can be utilized to estimate the chemical and filtration requirements for the full-scale injection project.

5.3 Application of the test results to injection wells requires consideration of test core selection and geometry effects.

5.4 This practice as described assumes that the water does not contain free oil or other immiscible hydrocarbons. The presence of free oil would require the method to be modified to account for the effect of oil saturation in the test cores on the water permeability.

6. Sources of Rock-Water Interactions

6.1 Water injected into a porous rock may interact with the rock to reduce the permeability as a result of the formation of precipitates, clay swelling, clay dispersion, or the migration of other fine solids.

6.2 Rock-water interactions are more common in sandstones than in carbonate rocks. However, within carbonate rocks dissolved iron in the injection water may precipitate especially in the presence of dissolved oxygen. Alkaline precipitates (CaCO_3 and Mg(OH)_2) may also form in carbonate rocks.

6.2.1 Dissolved hydrogen sulfide in the presence of dissolved iron and oxygen can also be a problem in waters injected into carbonate and sandstones resulting in precipitation of sulfides and hydroxides of iron.

6.3 The iron and alkaline precipitates described in 6.2 can also form from waters injected into sandstones. Swelling type clays (montmorillonite and mixed layer clays) and dispersible clays (kaolinite and chlorite) are potential sources of permeability losses due to changes in salinity or ionic content of the injected water compared to the natural waters in the formation. In some sandstones fine mica particles have been caused to migrate by the injection of a potassium ion deficient water.

6.4 In some instances in both sandstones and carbonates some fine particles are released to migrate as a result of water saturating the cleaned and dried test cores.

7. Apparatus

7.1 A schematic diagram of the test apparatus is shown in Fig. 1. The component parts are assembled from commercially

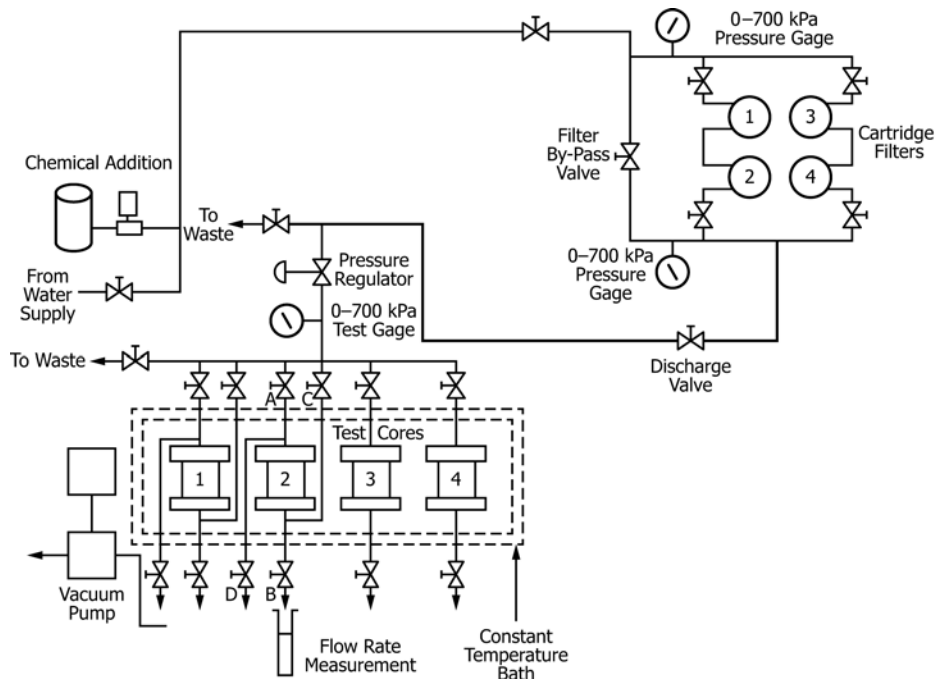

FIG. 1 Schematic of Test Equipment

available laboratory apparatus with the exception of the core holders (Fig. 2). While four cores are shown in Fig. 1 the number used in a test is optional. The apparatus essentially consists of a filtration section and a core flood section. The various components are connected with plastic or stainless steel flow lines with required valves and gauges as illustrated.

7.2 The filtration section is assembled from four cartridge filter holders mounted two each in series. Valves are installed to permit flow through either filter pair or to bypass the filters. Pressure gauges are included for monitoring the inlet and discharge pressure of the filters. Commercial filters are available with ratings ranging as low as 0.2 μm . The rated sizes used in the on-site core flood tests generally range from 0.45 to 10 μm . The filter holders should be provided with vents to saturate the filters and purge air from the system.

7.3 The core flood section of the apparatus consists of a laboratory constant temperature bath rated for up to 150°C (302°F) and of adequate capacity to hold up to four core holders (Fig. 2). Necessary valves and gauges are provided. As shown in Fig. 1, two of the core holders (No. 1 and No. 2) are plumbed to allow the flow through the cores to be reversed without removing the core holders. The pressure to the core flood section is controlled with a regulator, and a test gauge is used to accurately monitor the test core inlet pressure. The test core discharge pressure is atmospheric when the apparatus is assembled as shown in Fig. 1.

7.3.1 Another option is to control the discharge at a pressure above atmospheric by the addition of a regulator on each core sample discharge line. This option is recommended if the evolution of dissolved gas is anticipated from the water as it flows through the test core.

7.4 An alternative to the core holders (Fig. 2) is a Hassler-type permeability cell (API RP40) which uses a rubber or plastic sleeve to form the seal around the core sample. A high-pressure air (nitrogen) or liquid supply to maintain the seal would be required.

7.5 The operating gauge pressure of the test apparatus is usually 700 kPa (100 psig) or less.

7.6 As shown in Fig. 1, facilities may also be provided for the addition of chemicals to the water being tested. A chemical supply tank and an injection pump with pressure and flow ratings corresponding to specific needs would be required.

7.7 The apparatus is attached to a line carrying the water being tested. Usually, the line pressure of the water source (regulated as required) satisfies the pressure requirement for flowing the water through the filters and test cores. If the supply pressure is insufficient, a small pump capable of delivering about 1 L/min at 700 kPa is used.

7.8 Other required apparatus are the following:

7.8.1 Mechanical (non-aspirator type) vacuum pump,

7.8.2 Assorted beakers (250 to 1000 mL),

7.8.3 Assorted graduated cylinders (10 to 100 mL),

7.8.4 Stopwatch,

7.8.5 Vacuum tubing, and

7.8.6 Assorted tools for assembling and disassembling the equipment as required.

8. Procedure

8.1 Core Selection:

8.1.1 Choose proper core samples to yield the most meaningful test results through close coordination with geologists, chemists, and engineers responsible for the water injection project.

8.1.2 To assist in that choice include well logs, mineralogy, porosity, pore size distribution, permeability, and other core descriptive data.

8.1.3 Choose test cores to represent the zones that will receive the injected water. The best samples are from whole cores cut from those zones. Prepare sufficient samples to represent the ranges of permeability, porosity, and mineralogy of the injected zones. Consider the presence of natural fractures.

8.1.4 Select the number and properties of the cores for a particular test according to one of the following options:

8.1.4.1 Use cores having similar properties (porosity, permeability, mineralogy, etc.). Average the results.

8.1.4.2 Use a set of cores with one of these properties different in each core to test the effect of this property on the test results.

8.1.5 If cores from the flooded zone are not available, choose another zone with similar properties as the next best alternative sample source. As a third choice use synthetic core material (alumina, silica, porous glass, etc.).

8.2 Core Sample Preparation:

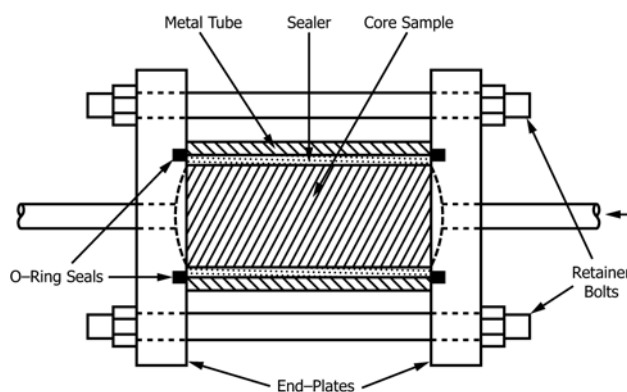

FIG. 2 Schematic Diagram of Sample Holder

8.2.1 Follow the recommended procedures for core handling, preservation, cutting, and cleaning described in API RP40. (This extensive document describes various procedures and options that the investigator may choose depending on the type and condition of the cores being tested.) Related ASTM standards are Guide [D420](#), Test Method [D2434](#), and Test Method [D4404](#).

8.2.2 The preferred sample dimensions for the core flood test are 19 mm (0.75 in.) to 38 mm (1.5 in.) outside diameter with a minimum length to diameter ratio of 1:0.

8.2.3 Carry out the following procedure for each core sample in the set to be tested:

8.2.3.1 Cut the core sample parallel to the formation bedding plane and then clean by solvent-extraction to remove residual hydrocarbons and water from the pore space. Dry the sample and determine the porosity according to the recommended procedures in API RP40.

8.2.3.2 Use the air permeability of the core sample as a guide for choosing representative samples of the formation being tested. The procedure for measuring air permeabilities is described in API RP27.

8.2.3.3 Seal the core sample with an epoxy resin or other suitable sealant in a metal (stainless steel, aluminum, brass) tube having an inside diameter about 6.4 mm (0.25 in.) larger than the outside diameter of the sample.

8.2.3.4 Machine the ends of the core sample and metal tube flat and perpendicular to the tube axis. Generally a stream of compressed air on the core ends during machining will prevent the intrusion of fines into the rock pores.

8.2.3.5 Mount the metal tube (containing the core sample) in a holder designed to allow water to be flowed through the sample. An example of such a sample holder is shown schematically in [Fig. 2](#).

8.3 Vacuum Saturation of Test Cores :

8.3.1 Install a 10- μm rated cartridge in filter No. 1 and a 0.45- μm cartridge in filter No. 2. Close valves to and from filters No. 3 and No. 4, the filter bypass valve, and valves to all core sample holders.

8.3.2 Open the valve-to-waste upstream and downstream of the regulator and the valves to and from filters No. 1 and No. 2. Start water flow through the filters to waste.

8.3.3 Close the valve-to-waste upstream of the pressure regulator. Set the regulator at about 120 kPa (17 psi) more than the pressure planned for the test. After about 2 min, close the valve-to-waste downstream of the regulator.

8.3.4 Mount from one to four sample cores in the holders (lines should not contain water) and attach the core sample holders to the valves.

8.3.5 Open the valves on the effluent ends of the core holders and attach the vacuum pump (with vacuum tubing) to the lines from the effluent end of the core holders. Run the vacuum pump for at least 1 h noting the vacuum gauge on the pump to check for leaks.

8.3.6 After at least 1 h, close the valves from the effluent ends of core holders and shut off and disconnect the vacuum pump and tubing.

8.3.7 Open the valve-to-waste downstream of the regulator to check water flow and then close the valve. Open the valves

to the inlet ends of core holders one at a time to begin saturation of the evacuated core samples. Pressure on the test gauge should read at least the pressure that will be used during the test. Adjust the regulator as required. Leave the system shut-in with pressure on the test cores for at least 30 min.

8.3.8 Close the valves to the core holders to await next step.

8.3.9 This procedure assumes sample cores are to be vacuum saturated with the same water used in the core flood test. If a special water or brine is to be used as the saturating fluid, the procedure is the same, except a valving arrangement is needed near the water supply valve to allow for flow of the required fluids. In all cases filter the saturating fluid to 0.45 μm .

8.4 Initial Permeability Measurement :

8.4.1 The initial permeability of the test core with 0.45- μm filtered water is the base value to which permeability changes are compared.

8.4.2 Follow the procedures in [8.1 – 8.3](#) so that the cores have been mounted, vacuum saturated, and under pressure and 0.45- μm filtered water is available upstream of the test cores. Set and allow the constant temperature bath to become stabilized at the test temperature. (Use water in the bath if the test temperature is less than 80°C (176°F). Use another heating medium such as silicone oil at higher temperatures.)

8.4.3 Open the valve-to-waste downstream of the regulator momentarily to check flow.

8.4.4 Open the valves to the test cores. Place a 500-mL beaker under the discharge tube from each core holder. Open the valves at the effluent end of each test core.

8.4.5 Reset the upstream pressure, if needed, using the regulator. It should be noted that the method described herein calls for a constant, regulated pressure across the core sample during the test. As an alternative use a constant flow pump for each core. While this more closely simulates the field practice of injecting water at constant rate, the cost for such pumps (high-pressure liquid chromatography pumps, for instance) generally does not justify their use.

8.4.6 Record the water volume collected in the beakers.

8.4.7 After about 50 to 100 mL of water has been collected, measure the rate of volume throughput. This is done with a 10 or 20-mL graduated cylinder and stopwatch. Record this rate and the corresponding cumulative volume throughput. At constant pressure drop across the test cores and constant test temperature, this rate is proportional to the initial permeability.

8.4.8 As an alternative to the use of graduated cylinders, weigh the water collected. This increases the accuracy of the throughput volume measurement (although the graduated cylinder volume is usually sufficiently accurate) but requires taking a balance to the site.

8.4.9 Measure the flow rate several times noting if it is increasing or decreasing with volume throughput. If the rate is increasing, continue flooding the test cores with 0.45- μm filtered water until a constant rate is obtained or the rate begins to decrease. A decreasing flow rate indicates the water is probably interacting with the test core to cause a decline in permeability.

8.4.10 Generally, at this point, the operation is continued directly into the next phase of the test (chemical test or filtration test) without stopping the flow of water. If the flow is

stopped by closing the input and discharge valves of the test cores, determine a stable, baseline permeability again with 0.45- μm filtered water before proceeding to the next phase of the test program.

8.4.11 A rock-water interaction causing a decline in permeability is countered by either a special treatment of the formation rock or a change in chemistry of the injection water by changing salinity or ionic composition. The degree of damage caused by the interaction can be indicated by continuing flow of 0.45- μm filtered water and monitoring the permeability until the permeability either levels off at a lower value or approaches zero. Examine the test core visually and microscopically at the end of the test to provide useful information regarding the cause of the interaction.

8.4.12 Consider as an option when a water-rock interaction is indicated reversing the flow of the filtered water through the core as described in 8.7. This procedure can verify that the decline in permeability is not due to fine solids (less than 0.45 μm) built up on the core inlet face.

8.4.13 Before proceeding to the filtration tests, modify the injection water or treat the test cores from a formation exhibiting a rock-water interaction so a stable initial permeability is achieved by the procedure described above.

8.5 *Unfiltered Water Core Flood Test:*

8.5.1 This test demonstrates the effect of injecting unfiltered water and if there is a need for filtration.

8.5.2 Mount a set of test cores and determine their initial permeability as described in 8.4. Treat the test cores or water to prevent rock-water interaction as required. Bath temperature is constant.

8.5.3 Without interrupting the water flow to the test cores, open the filter bypass valve and close the valves to and from the filters (Fig. 1). Continue collecting effluent water and record the cumulative volume throughput and volume collected at point when injected water is changed. Maintain regulated pressure.

8.5.4 After about 50 mL of unfiltered water has been collected, measure the rate of volume throughput. Continue monitoring and recording the flow rate and cumulative volume throughput noting if the rate is decreasing.

8.5.5 Continue until the flow rate levels off or the permeability is approaching zero.

8.5.6 Terminate the test by: opening the valves to and from the filters (10 μm followed by 0.45 μm); closing filter bypass; closing core inlet and discharge valves; and opening valve-to-waste after the regulator. Flow water to waste for 5 to 10 min to flush unfiltered water from the system.

8.5.7 After disassembling the core holders, note condition of the upstream face of test cores (discoloration, filter cake, etc.).

8.6 *Filtration Requirement Test :*

8.6.1 The objective of this test is to determine the filtration size requirement to prevent plugging by particulates.

8.6.2 Mount a set of test cores and determine initial permeabilities as described in 8.4. Treat the test cores or water to prevent rock-water interaction as required. Bath temperature is constant.

8.6.3 Install a 10- μm filter in holder No. 3 (Fig. 1) and a 1.2- μm filter in holder No. 4. Saturate the filters and purge the air. Open the valves to and from filter holders No. 3 and No. 4. Do not interrupt the flow to the cores. Maintain a constant pressure. Close the valves to and from filter holders No. 1 and No. 2. Record the cumulative throughput volume.

8.6.4 Measure the water flow rate. Monitor and record the flow rate and volume throughput noting if the rate begins to decline.

8.6.5 If no flow rate decline is noted, install a 3- μm filter in holder No. 2 (holder No. 1 already contains a 10- μm filter). Saturate the filter and purge the air. Do not interrupt flow to the test cores. Maintain a constant pressure. Open the valves to and from filter holders No. 1 and No. 2 and close the valves to and from holders No. 3 and No. 4. Record the cumulative throughput volume.

8.6.6 Measure the water flow rate. Monitor and record the flow rate and volume throughput noting if rate begins to decline.

8.6.7 If no flow rate decline is noted, install a 5- μm filter in holder No. 4 and proceed as outlined above. If a flow rate decline is still not seen, remove the filter from holder No. 2 and proceed as outlined.

8.6.8 Select other filtration levels as desired.

8.7 *Flow Reversal:*

8.7.1 Sample core holders No. 1 and No. 2 in Fig. 1 have inlet and outlet valves that allow the direction of water flow to be reversed without the core being removed. Holder No. 2 will be used to outline the procedure.

8.7.2 Reversing the flow through a partially plugged core (as in 8.5 or 8.6) is done to simulate backflowing an injection well to remove solids that have built up during injection. Therefore, it is assumed that the water in the core test is filtered to 0.45 μm and appropriate filters are installed in filter holder No. 2 or No. 4.

8.7.3 During forward flow, valves A and B are open and valves C and D are closed. To reverse flow, close valve B, open valve C, close valve A, and open valve D. Collect and measure the water volume and flow rate from valve D and determine the permeability. Continue until a stable permeability is achieved.

8.7.4 To return to forward flow, close valve D, open valve A, close valve C, and open valve B. Collect and measure the water volume and flow rate from valve B and determine the permeability.

9. Calculation

9.1 *Permeability*— Different units of permeability are used in different industries. For the purpose of defining the permeability around a well, the American Petroleum Institute uses the darcy or millidarcy (0.001 darcy). The data from a core flood test from which the permeability of a test core is computed include the following units. Based on these units, the permeability of the test core is the following:

$$k, \text{ millidarcys} = 16890 \cdot \frac{q \cdot \mu \cdot \Delta x}{A \cdot \Delta P}$$

where:

k = test core permeability, millidarcys,

- q = water flow rate, mL/min,
- μ = water viscosity, cp,
- Δx = length of test core sample, mm,
- A = cross sectional area to flow, mm², and
- ΔP = pressure differential across test core, kPa.

9.2 *Permeability Ratio*—The ratio of the test core permeability, k , at any time to the initial permeability, k_i , is expressed as follows:

$$N_k = \frac{k}{k_i}$$

This ratio is used to normalize the permeability data in terms of the initial permeability and indicate the relative effects of plugging, water-rock interactions, etc.

9.3 *Pore Volume*— The water volume injected in a porous rock is often reported in terms of pore volumes. The pore volume of a test core that is Δx mm long, with A representing the cross sectional area, mm², and with a percent porosity of ϕ , is the following:

$$V_p = 10^{-5} \phi \Delta x A, \text{ mL}$$

and the number of pore volumes injected is:

$$N_v = \frac{V}{V_p}$$

where:

V = volume injected, mL.

9.4 *Graphing Test Data*—Graphical presentations of the core test data are shown in Fig. 3 (rock-water interaction) and Fig. 4 (filtration test). In both cases, the permeability ratio is plotted as a function of the cumulative water throughput.

10. Interpretation

10.1 *Rock-Water Interactions*—On-site core flood tests indicate rock-injection water interactions that may reduce formation permeability and well injectivity. In turn, the procedure described herein can be used to demonstrate the effectiveness of a formation rock treatment or injection water change to prevent the interaction. The core test results are used to determine the treatment volumes or concentrations required to treat the formation around the injection wellbore. Similarly, the chemical volumes and costs to treat the injection water can be estimated.

10.1.1 The rock-water interaction illustrated in Fig. 3 was the result of iron hydroxide precipitation as the water flowed through the test core.

10.2 *Filtration Requirement Test* —The results of core flood filtration tests are used as guidelines for specifying the filtration requirement to minimize injection well damage caused by suspended solids in the injected water. The example in Fig. 4 indicates a very small permeability loss when the filtration level was 3.0 μm but significant permeability loss at 5.0 μm or larger.

10.3 *Flow Reversal*— The results of core flow reversal tests indicate how much of the lost permeability may be recovered by backflowing injection wells. The objective is to flush particulates from the formation face as injected water backflows out of the well.

10.4 *Application of Test Results to Injection Well*—The interpretation of the test results as applied to actual injection conditions depends on the proper choice of test cores in terms of permeability and mineralogy. Real formations contain a variety of permeabilities and mineralogies. The greatest use of

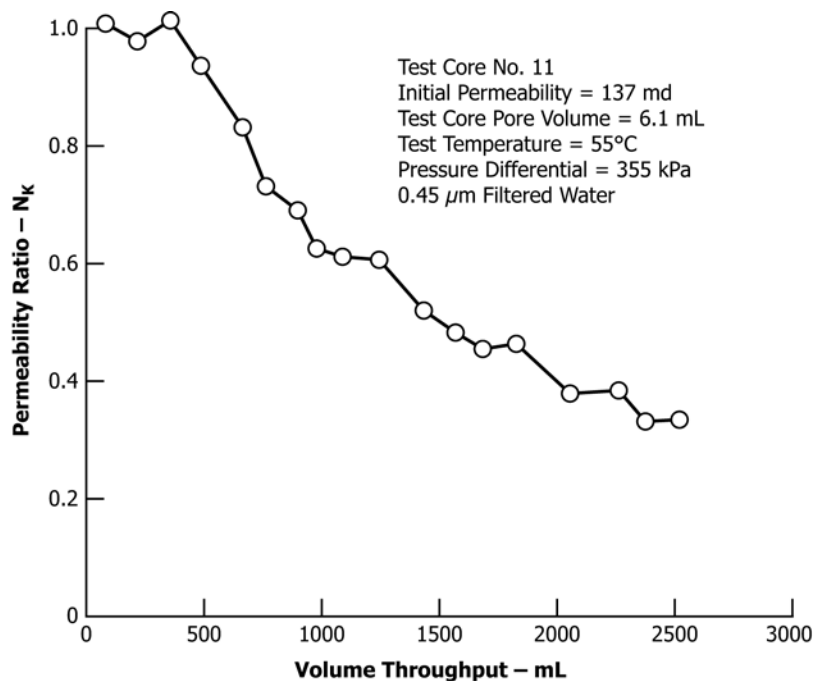

FIG. 3 Example of Core Test with Rock-Water Interaction

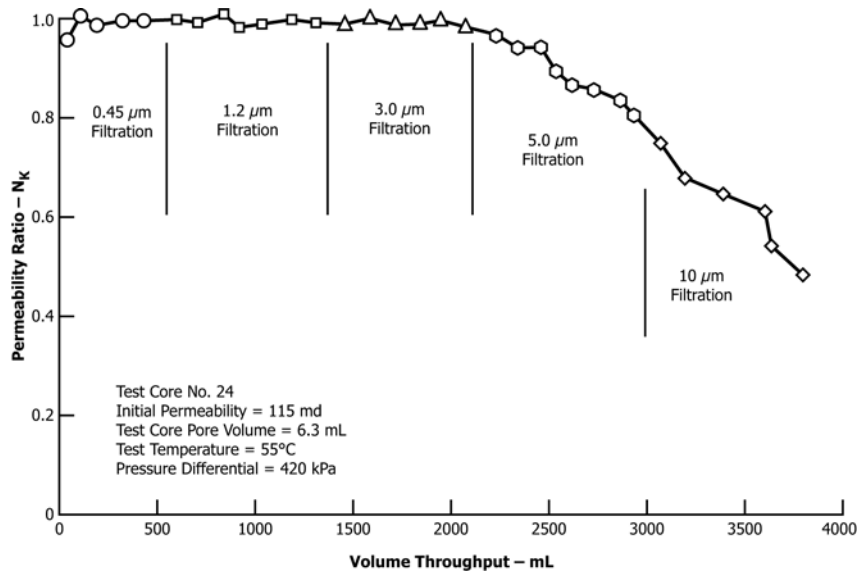

FIG. 4 Example of Filtration Test Results

the core test results can now be made as the filtration and rock-water interaction data are related to the rock properties and then in turn to the injection well performance.

10.5 There are geometry effects that must be considered in comparing core test results with well performance. In a core test the permeability is measured over only a few centimetres. Consequently, permeability changes are amplified. In an injection well permeability changes (as seen by changes in injectivity) are averaged over large distances. The geometry of the wellbore (openhole, cemented, and perforated, etc.) must also be taken into account.

11. Precision and Bias

11.1 Due to the large number of variables encountered in this practice no statement of precision can be made. Interpre-

tation of test results is subjective. Results are a function of the individual equipment assembly, variability of natural core material, core handling, and sample preparation.

12. Keywords

12.1 enhanced oil recovery; permeability; secondary recovery; water disposal; water injectivity

SUMMARY OF CHANGES

Committee **D19** has identified the location of selected changes to this standard since the last issue (D4520 – 03(2008)) that may impact the use of this standard.

(1) The SI statement was added to section 1.

(2) Section 3 format was updated.

ASTM International takes no position respecting the validity of any patent rights asserted in connection with any item mentioned in this standard. Users of this standard are expressly advised that determination of the validity of any such patent rights, and the risk of infringement of such rights, are entirely their own responsibility.

This standard is subject to revision at any time by the responsible technical committee and must be reviewed every five years and if not revised, either reapproved or withdrawn. Your comments are invited either for revision of this standard or for additional standards and should be addressed to ASTM International Headquarters. Your comments will receive careful consideration at a meeting of the responsible technical committee, which you may attend. If you feel that your comments have not received a fair hearing you should make your views known to the ASTM Committee on Standards, at the address shown below.

This standard is copyrighted by ASTM International, 100 Barr Harbor Drive, PO Box C700, West Conshohocken, PA 19428-2959, United States. Individual reprints (single or multiple copies) of this standard may be obtained by contacting ASTM at the above address or at 610-832-9585 (phone), 610-832-9555 (fax), or service@astm.org (e-mail); or through the ASTM website (www.astm.org). Permission rights to photocopy the standard may also be secured from the Copyright Clearance Center, 222 Rosewood Drive, Danvers, MA 01923, Tel: (978) 646-2600; <http://www.copyright.com/>