



Standard Test Method for Determination of Carbonyls in C₄ Hydrocarbons¹

This standard is issued under the fixed designation D4423; the number immediately following the designation indicates the year of original adoption or, in the case of revision, the year of last revision. A number in parentheses indicates the year of last reapproval. A superscript epsilon (ϵ) indicates an editorial change since the last revision or reapproval.

1. Scope

1.1 This test method covers the determination of carbonyls (ketones and aldehydes) in C₄ hydrocarbons. This test method was tested on polymerization-grade 1,3-butadiene.

1.2 The applicable range for this test method is 0 mg/kg to 50 mg/kg carbonyls calculated as acetaldehyde.

1.3 Other C₄ hydrocarbons and their mixtures besides polymerization-grade 1,3-butadiene could be tested using this same test method. However, the precision section of this test method covers only carbonyls in applicable range as listed in 1.2, as found in polymerization-grade 1,3-butadiene.

1.4 **WARNING**—Mercury has been designated by many regulatory agencies as a hazardous material that can cause central nervous system, kidney and liver damage. Mercury, or its vapor, may be hazardous to health and corrosive to materials. Caution should be taken when handling mercury and mercury containing products. See the applicable product Material Safety Data Sheet (MSDS) for details and EPA's website—<http://www.epa.gov/mercury/faq.htm>—for additional information. Users should be aware that selling mercury and/or mercury containing products into your state or country may be prohibited by law.

1.5 The values stated in SI units are to be regarded as standard. No other units of measurement are included in this standard.

1.6 *This standard does not purport to address all of the safety concerns, if any, associated with its use. It is the responsibility of the user of this standard to establish appropriate safety and health practices and determine the applicability of regulatory limitations prior to use.*

2. Referenced Documents

2.1 *ASTM Standards*:²

D484 Specification for Hydrocarbon Dry Cleaning Solvents (Withdrawn 1982)³

D1193 Specification for Reagent Water

E1 Specification for ASTM Liquid-in-Glass Thermometers

3. Summary of Test Method

3.1 A measured amount of sample is added to an alcoholic hydroxylamine hydrochloride solution that has been adjusted to a given coloration using either alcoholic acid or base. The carbonyls will react with the hydroxylamine hydrochloride releasing an equivalent amount of hydrochloric acid which is then back-titrated to the original coloration. A blank containing only methanol and sample is titrated and the sample's results are calculated using the blank adjustment. Results are reported as milligrams per kilogram carbonyls as acetaldehyde.

4. Significance and Use

4.1 The determination of the carbonyl content of polymerization-grade 1,3-butadiene is necessary, since in some polymerization reactions, the presence of carbonyls in excess over some specified amount can have a deleterious effect upon the polymer properties or the reaction itself, or both.

5. Apparatus

5.1 *Bunsen Valves*—A device constructed so that when used with an Erlenmeyer flask, the sample vapors can exit the flask while protecting the flask's liquid contents. See Fig. 1 for details.

5.2 *Cooling Coil*—Prepare a cooling coil by winding about 10 cm to 15 cm of seamless copper tubing (about 6 mm diameter) on a short length of pipe (about 1.5 cm to 2.0 cm diameter), allowing sufficient length of tubing at the end of the coil to connect it to the sample source. Attach a valve at a point that would not extend more than 8 cm above the surface of the cooling bath liquid. To the valve, attach a 6 cm to 8 cm length

¹ This test method is under the jurisdiction of ASTM Committee D02 on Petroleum Products, Liquid Fuels, and Lubricants and is the direct responsibility of Subcommittee D02.D0.04 on C4 Hydrocarbons.

Current edition approved April 1, 2015. Published May 2015. Originally approved in 1984. Last previous edition approved in 2010 as D4423 – 10. DOI: 10.1520/D4423-10R15.

² For referenced ASTM standards, visit the ASTM website, www.astm.org, or contact ASTM Customer Service at service@astm.org. For *Annual Book of ASTM Standards* volume information, refer to the standard's Document Summary page on the ASTM website.

³ The last approved version of this historical standard is referenced on www.astm.org.

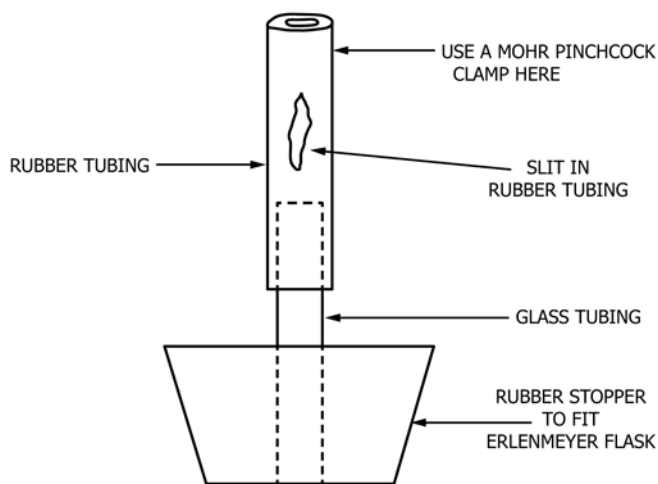

FIG. 1 Apparatus

piece of tubing bent downward so that the hydrocarbon liquid can be directed into the receiving container.

5.3 *Dewar Flask*—The Dewar flask must be of sufficient volume to completely immerse the main portion of the cooling coil except for the extremities necessary for receiving and delivering the sample through the coil.

5.4 *Erlenmeyer Flasks*, 250 mL capacity.

5.5 *Volumetric Flasks*, 1 L capacity. These flasks should be Class A glassware.

5.6 *Graduated Cylinders*—100 mL capacity, glass cylinders, graduated in 1 mL or 2 mL divisions.

5.7 *Microburets*, 2.00 mL or 5.00 mL capacity. The microburets should be Class A glassware with 0.01 mL or 0.02 mL divisions or less. It is advisable to have the buret's tip end equipped with a syringe needle to dispense very small drops of titrant.

5.8 *Sample Cylinders*—These should be of sufficient volume to give the required amount of sample for testing. Stainless steel cylinders equipped with needle valves should be used. It is suggested that a 500 mL-capacity cylinder be the minimum size to be used for butadiene.

5.9 *Thermometer*—For observing temperatures below -45°C . The Low Cloud and Pour Point Thermometer, conforming to the requirements for ASTM Thermometer 6C, as prescribed in Specification E1, is satisfactory. Thermometer 6C has a range from -80°C to $+20^{\circ}\text{C}$. Temperature measuring devices that cover the temperature range of interest, such as the ASTM 1C thermometer, or liquid-in-glass thermometers, thermocouples, or platinum resistance thermometers that provide equivalent or better accuracy and precision may be used.

6. Reagents and Materials

6.1 *Purity of Reagents*—Reagent grade chemicals should be used in all tests. Unless otherwise indicated, it is intended that all reagents conform to the specifications of the Committee on Analytical Reagents of the American Chemical Society where

such specifications are available.⁴ Other grades may be used, provided it is first ascertained that the reagent is of sufficiently high purity to permit its use without lessening the accuracy of the determination.

6.2 *Purity of Water*—Unless otherwise indicated, references to water shall be understood to mean Type II reagent water conforming to Specification D1193.

6.3 *Alcoholic Hydrochloric Acid (0.05 N)*—Dilute 4.2 mL of concentrated hydrochloric acid (**Warning**—Poison. Corrosive. May be fatal if swallowed. Liquid and vapor cause severe burns. Harmful if inhaled.) to volume with anhydrous methanol in a 1 L volumetric flask. Use the alcoholic 0.05 N potassium hydroxide solution to standardize the HCl solution.

6.4 *Alcoholic Hydroxylamine Hydrochloride*—Dissolve 35.0 g of hydroxylamine hydrochloride (**Warning**—May be irritating to skin, eyes, or mucous membranes. Harmful if inhaled.) in 3.5 L of anhydrous methanol. (**Warning**—Flammable. Vapor harmful. May be fatal or cause blindness if swallowed or inhaled. Cannot be made nonpoisonous.)

6.5 *Alcoholic Potassium Hydroxide (0.05 N)*—Dissolve 3.3 g of potassium hydroxide in anhydrous methanol. (**Warning**—Corrosive. Can cause severe burns or blindness. Evolution of heat produces a violent reaction or eruption upon too rapid mixture with water.) Make to volume with methanol in a 1 L volumetric flask. Standardize against a primary standard, potassium acid phthalate.

6.6 *Dry Ice (Carbon Dioxide Solid)*—(**Warning**—Extremely cold (-78.5°C). Liberates heavy gas which may cause suffocation. Contact with skin causes burns or freezing, or both. Vapors may react violently with hot magnesium or aluminum alloys.)

6.7 *Stoddard Solvent*—Conforming to the specification listed in Specification D484. (**Warning**—Combustible. Vapor harmful.)

6.8 *Thymol Blue Indicator*—Dissolve 0.04 g of thymol blue in 100 mL of anhydrous methanol. (**Warning**—Flammable. Vapor harmful. May be fatal or cause blindness if swallowed or inhaled. Cannot be made nonpoisonous.)

7. Preparation of Apparatus

7.1 *Dry Ice-Stoddard Solvent Bath*—Add a sufficient quantity of Stoddard solvent into the Dewar flask to ensure that the cooling coil will be submerged in the liquid plus dry ice (solid CO_2). (**Warning**—See 6.6 and 6.7.) Carefully add sufficient dry ice to the Stoddard solvent to obtain a temperature of at least -50°C . (**Warning**—Great care must be taken during this step. Do not add the dry ice all at once, but in small pieces, especially at the beginning. Wear protective gloves and adequate eye protection to prevent any contact with the extremely cold materials.) Attach the sample cylinder containing the

⁴ *Reagent Chemicals, American Chemical Society Specifications*, American Chemical Society, Washington, DC. For suggestions on the testing of reagents not listed by the American Chemical Society, see *Analar Standards for Laboratory Chemicals*, BDH Ltd., Poole, Dorset, U.K., and the *United States Pharmacopeia and National Formulary*, U.S. Pharmacopeial Convention, Inc. (USPC), Rockville, MD.

butadiene (**Warning**—Extremely flammable gas under pressure. May form explosive peroxides upon exposure to air. Harmful if inhaled. Irritating to eyes, skin, and mucous membranes.) to the cooling coil and immerse the coil into the liquid. Support the sample cylinder in a cylinder rack or using a ring stand and appropriate clamps. Be sure the coil is positioned so that the delivery tip is free to dispense liquid butadiene into the Erlenmeyer flasks. After each use, be sure to clean the coil's interior with methanol. **DO NOT USE ACETONE.**

8. Procedure

8.1 Prepare a sample flask by pouring 50 mL of alcoholic hydroxylamine hydrochloride into a 250 mL Erlenmeyer flask.

8.2 Prepare a flask for use as a sample blank by pouring 50 mL of methanol into a 250 mL Erlenmeyer flask.

8.3 Add about 0.5 mL of thymol blue indicator solution to each flask.

8.4 Carefully add 0.05 *N* alcoholic KOH or alcoholic HCl to each flask until matching colors are obtained. The desired color is a yellow color with a slight, but distinct, orange coloration. It is important that this orange color is present at this point of the test. If the color is more yellow at this point, it would be easy to obtain a result of less than 1 mg/kg carbonyls on a sample containing over 100 mg/kg of carbonyls.

8.5 Stopper the flasks with the Bunsen valves. (This keeps the CO₂ vapor out of the flasks). Set the flasks on some crushed dry ice for a few minutes to cool the liquid contents. The color in the flasks may turn more yellow when cold, but this is not significant at this point. From this step forward, all operations must be carried out in a well-ventilated hood.

8.6 Cool a 100 mL graduated cylinder by holding it in the cooling bath for a few seconds. Then, when it is cold, collect 100 mL ± 1 mL butadiene into the graduated cylinder. Quickly, using a clean thermometer, measure the sample's temperature to the nearest 1 °C. Record this temperature as "T" for use later to obtain the sample weight. Pour this sample into the sample flask containing the alcoholic hydroxylamine hydrochloride solution. Replace the Bunsen valve on the flask and set aside. Again, collect 100 mL ± 1 mL of sample into the graduated cylinder. Pour this sample into the sample blank flask containing only the methanol. Replace the Bunsen valve and set aside.

8.7 Sample and sample blank can be titrated after 15 min while cold butadiene is in the flasks. If done, be careful to avoid vigorous agitation because some of the contents may boil over and be lost. It is advisable to allow as much of the butadiene as possible to evaporate before titration begins.

8.8 Titrate the sample flask's contents back to the original coloration, as described in 8.4, by using the alcoholic KOH. Record this value as "A." Set the flask aside in the hood for 5 min before pouring out the contents. If it turns red, the carbonyl concentration may be high or there is contamination in the flask. Continue the titration until the flask's contents will not turn red after standing 5 min.

8.9 Titrate the sample blank flask's contents. If the solution is red, use the standard KOH solution. If it is yellow, use the standard HCl solution. In either case, unless the sample blank's contents are still at the original coloration, titrate with the appropriate titrant back to the same, original coloration as described in 8.4. Record this value as "E."

9. Calculation

9.1 Calculate as follows when the sample has no free acid or free base:

$$\text{mg/Kg carbonyls (as acetaldehyde)} = A \times Nb \times 44050/V \times D \quad (1)$$

where:

A = alcoholic KOH titration, mL,

Nb = normality of KOH solution,

V = sample volume, mL, and

D = butadiene density at temperature *T* (found by using **Table 1**).

9.2 Calculate as follows when the sample has free acid:

$$\text{mg/Kg carbonyls (as acetaldehyde)} = (A - Bb) \times Nb \times 44050/V \times D \quad (2)$$

where:

Bb = alcoholic KOH used for the sample blank, mL.

9.3 Calculate as follows when the sample has free base:

$$\text{mg/Kg carbonyls (as acetaldehyde)} = ((A \times Nb) + (Ba \times Na)) \times 44050/V \times D \quad (3)$$

where:

Na = normality of alcoholic HCl

Ba = alcoholic HCl used for the sample blank, mL

10. Precision and Bias

10.1 *Precision*—The precision of this test method as determined by statistical examination of interlaboratory results is as follows:

10.1.1 *Repeatability*—The difference between two test results obtained by the same operator with the same apparatus under constant operating conditions on identical test material would, in the long run, in normal and correct operation of the test method, exceed the following value in only one case in twenty, where *X* = the average of the two test results:

$$14 \% \text{ of } X$$

TABLE 1 Density of Butadiene at Various Temperatures

NOTE 1—These data may be used in a graphical manner for better interpolation between data points.

Temperature, °C	Density, g/mL
-45	0.6958
-40	0.6903
-35	0.6848
-30	0.6793
-25	0.6737
-20	0.6681
-15	0.6625
-10	0.6568
-5	0.6510
0	0.6452

10.2 *Reproducibility*—The difference between two single and independent results obtained by different operators working in different laboratories on identical test material would, in the long run, in the normal and correct operation of the test method, exceed the following value in only one case in twenty, where X = average of two test results:

88 % of X

10.3 *Bias*—Since there is no accepted reference material for determining the bias for the procedure in this test method for measuring carbonyls, no statement on bias is being made.

11. Keywords

11.1 butadiene; C₄ hydrocarbons; carbonyls; titration

ASTM International takes no position respecting the validity of any patent rights asserted in connection with any item mentioned in this standard. Users of this standard are expressly advised that determination of the validity of any such patent rights, and the risk of infringement of such rights, are entirely their own responsibility.

This standard is subject to revision at any time by the responsible technical committee and must be reviewed every five years and if not revised, either reapproved or withdrawn. Your comments are invited either for revision of this standard or for additional standards and should be addressed to ASTM International Headquarters. Your comments will receive careful consideration at a meeting of the responsible technical committee, which you may attend. If you feel that your comments have not received a fair hearing you should make your views known to the ASTM Committee on Standards, at the address shown below.

This standard is copyrighted by ASTM International, 100 Barr Harbor Drive, PO Box C700, West Conshohocken, PA 19428-2959, United States. Individual reprints (single or multiple copies) of this standard may be obtained by contacting ASTM at the above address or at 610-832-9585 (phone), 610-832-9555 (fax), or service@astm.org (e-mail); or through the ASTM website (www.astm.org). Permission rights to photocopy the standard may also be secured from the Copyright Clearance Center, 222 Rosewood Drive, Danvers, MA 01923, Tel: (978) 646-2600; <http://www.copyright.com/>