



Standard Test Method for Determining Micropore Volume and Zeolite Area of a Catalyst¹

This standard is issued under the fixed designation D4365; the number immediately following the designation indicates the year of original adoption or, in the case of revision, the year of last revision. A number in parentheses indicates the year of last reapproval. A superscript epsilon (ϵ) indicates an editorial change since the last revision or reapproval.

1. Scope

1.1 This test method covers the determination of total surface area and mesopore area. From these results are calculated the zeolite area and micropore volume of a zeolite containing catalyst. The micropore volume is related to the percent zeolite in the catalyst. The zeolite area, a number related to the surface area within the zeolite pores, may also be calculated. Zeolite area, however, is difficult to interpret in physical terms because of the manner in which nitrogen molecules pack within the zeolite.

1.2 The values stated in SI units are to be regarded as standard. No other units of measurement are included in this standard.

1.3 *This standard does not purport to address all of the safety concerns, if any, associated with its use. It is the responsibility of the user of this standard to establish appropriate safety and health practices and determine the applicability of regulatory limitations prior to use.* For a specific precautionary statement, see [Note 3](#).

2. Referenced Documents

2.1 ASTM Standards:²

- [D3663 Test Method for Surface Area of Catalysts and Catalyst Carriers](#)
- [D3906 Test Method for Determination of Relative X-ray Diffraction Intensities of Faujasite-Type Zeolite-Containing Materials](#)
- [E177 Practice for Use of the Terms Precision and Bias in ASTM Test Methods](#)
- [E456 Terminology Relating to Quality and Statistics](#)
- [E691 Practice for Conducting an Interlaboratory Study to Determine the Precision of a Test Method](#)

¹ This test method is under the jurisdiction of ASTM Committee D32 on Catalysts and is the direct responsibility of Subcommittee D32.01 on Physical-Chemical Properties.

Current edition approved April 1, 2013. Published August 2013. Originally approved in 1984. Last previous edition approved in 2008 as D4365 – 95(2008). DOI: 10.1520/D4365-13.

² For referenced ASTM standards, visit the ASTM website, www.astm.org, or contact ASTM Customer Service at service@astm.org. For *Annual Book of ASTM Standards* volume information, refer to the standard's Document Summary page on the ASTM website.

3. Terminology

3.1 Definitions of Terms Specific to This Standard:

3.1.1 *mesopore (matrix) area of a catalyst*—the area determined from the slope of the t-plot.

3.1.2 *micropore volume of the catalyst*—the pore volume in pores having radii less than 1 nm, usually associated with the zeolite portion of the catalyst, and determined from the intercept of the t-plot.

3.1.3 *surface area of a catalyst*—the total surface of the catalyst pores. It is expressed in square metres per gram.

3.1.4 *zeolite area of a catalyst*—the difference between total surface area and mesopore area.

3.2 Symbols:

- P_{H_1} = initial helium pressure, torr
- P_{H_2} = helium pressure after equilibration, torr
- S_B = slope of BET plot, 11.7
- I_B = intercept of BET plot, 11.7
- S_t = slope of t-plot, 11.13
- I_t = intercept of t-plot, 11.13
- T_{H1} = temperature of manifold at initial helium pressure, °C
- T_{H2} = temperature of manifold after equilibration, °C
- $T_x'(i)$ = extra volume bulb temperature, °C
- $T_x(i)$ = extra volume bulb temperature, K
- $P_1(i)$ = initial N_2 pressure, torr
- $T_1(i)$ = manifold temperature at initial N_2 pressure, K
- $T_1'(i)$ = manifold temperature at initial N_2 pressure, °C
- $P_2(i)$ = pressure after equilibration, torr
- $T_2(i)$ = manifold temperature after equilibration, K
- $T_2'(i)$ = manifold temperature after equilibration, °C
- $P_0(i)$ = liquid nitrogen vapor pressure, torr
- $T_s(i)$ = liquid nitrogen temperature, K
- X = relative pressure, P_2/P_0
- V_d = volume of manifold, cm^3
- V_x = extra volume bulb, cm^3
- V_s = effective void volume, cm^3
- W_s = weight of sample, g
- W_t = tare weight of sample tube, g
- W_2 = weight of sample + tare weight of tube, g
- V_{ds} = volume of nitrogen in the dead-space, cm^3
- V_1 = see [11.4.3](#)

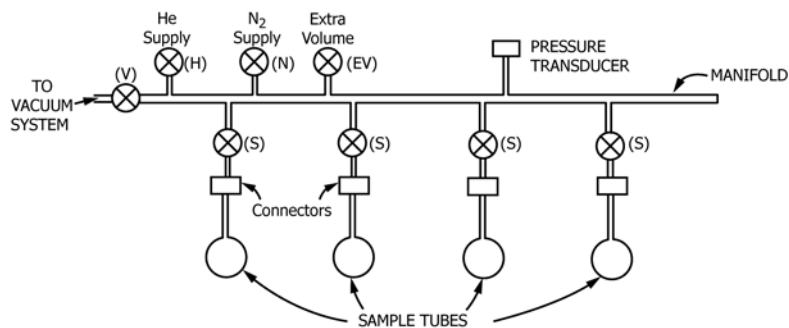

FIG. 1 Schematic Diagram of Surface Area Apparatus

- V_2 = see 11.4.4
- V_t = see 11.4.5
- V_a = see 11.4.7
- V_m = see 11.8
- BET(i) = see 11.4.8
- $t(i)$ = see 11.10

4. Summary of Test Method

4.1 The volume of nitrogen gas adsorbed by the catalyst at liquid nitrogen temperature is measured at various low-pressure levels by the catalyst sample at liquid nitrogen temperature. This is done by measuring pressure differentials resulting from introducing a fixed volume of nitrogen to the degassed catalyst in the test apparatus. This procedure is the same as Test Method D3663, that gives total surface area, but extends the pressure range to permit calculation of micropore volume and matrix surface area, by the t-plot method. Zeolite area is the difference between total area and matrix area.

5. Significance and Use

5.1 This gas adsorption method complements the X-ray procedure of Test Method D3906. This test method will be useful to laboratories that do not have X-ray diffractometers. Each test method can be calibrated by use of an appropriate series of mechanical mixtures to provide what may be termed percent zeolite. If there is disorder in the zeolite, the adsorption method will yield higher values than the X-ray method. The reverse will be true if some zeolite pores (micropores) are blocked or filled.

6. Apparatus

6.1 A schematic diagram of the apparatus is shown in Fig. 1. It may be constructed of glass or of metal. It has the following features:

6.1.1 *Distribution or Dosing Manifold*, having a volume between 20 and 35 cm³, (V_d), known to the nearest 0.05 cm³. This volume is defined as the volume between the stopcocks or valves and includes the pressure gage. It is preferred that this volume be thermostatted.

6.1.2 *Vacuum System*, capable of attaining pressures below 10⁻⁴ torr (1 torr = 133.3 Pa). This will include a vacuum gage (not shown in Fig. 1). Access to the distribution manifold is through the valve V.

6.1.3 *Pressure Sensing Devices or Pressure Transducer*, capable of measurements to the nearest 0.1-torr sensitivity in the range from 0 to 1000 torr (1 torr = 133.3 Pa).

NOTE 1—See, for example, the article by Joy for a description of a constant-volume manometer.³

6.1.4 *Valve (H)*, from the helium supply to the distribution manifold.

6.1.5 *Valve (N)*, from the nitrogen supply to the distribution manifold.

6.1.6 The connection between the sample tube and the S valve can be a standard-taper glass joint, a glass-to-glass seal, or a compression fitting.

6.1.7 *Extra Volume (EV) Bulb*, if employed, may be attached through valve EV. Its volume (V_x) should be 100 to 150 cm³, known to the nearest 0.05 cm³. V_x includes the volume of the stopcock bore in the glass apparatus. It is preferred that this volume be held at the same temperature as that of the distribution manifold.

NOTE 2—Modern commercial instruments automatically adjust the amounts dosed in order to produce data points at user-selected target pressures. Hence, the use of an EV bulb is optional. Some instruments can analyze multiple samples simultaneously and may use sample tubes with volumes outside of the range specified in this test method.

6.2 *Sample Tubes*, with volumes from 5 cm³ to 25 cm³ depending on the application. Markings should be placed on the sample tubes about 30 to 50 mm below the connectors to indicate the desired liquid nitrogen level if automatic control of liquid nitrogen level is not available.

6.3 *Heating Mantles or Small Furnaces*.

6.4 *Dewar Flasks*.

6.5 *Laboratory Balance*, with 0.1 mg (10⁻⁷ kg) sensitivity.

6.6 *Thermometer or Thermocouple*, for measuring the temperature of the distribution manifold, $T_1'(i)$ or $T_2'(i)$, in degrees Celsius.

6.6.1 The manifold may be thermostatted at a particular temperature, a few degrees above ambient, to obviate the necessity of recording this temperature at each reading.

6.7 *Thermometer or Thermocouple*, for measuring the temperature of the liquid nitrogen bath $T_s(i)$ in kelvins from which

³ Joy, A. S., *Vacuum*, Vol 3, 1953, p. 254.

P_0 values may be derived. This will preferably be a nitrogen vapor-pressure-thermometer, often referred to in a commercial instrument as a pressure saturation tube, from which P_0 values may be measured directly with greater precision, or a resistance thermometer from which P_0 values may be derived.

6.8 *Thermometer or Thermocouple*, for measuring the temperature of the EV bulb, $T_x'(i)$, if different from $T_1'(i)$ or $T_2'(i)$.

7. Reagents

7.1 *Purity of Reagents*—Reagent grade chemicals shall be used in all tests. Unless otherwise indicated, it is intended that all reagents shall conform to the specifications of the Committee on Analytical Reagents of the American Chemical Society, where such specifications are available.⁴ Other grades may be used, provided it is first ascertained that the reagent is of sufficiently high purity to permit its use without lessening the accuracy of the determination.

7.2 *Helium Gas*—A cylinder of helium gas at least 99.9 % pure.

7.3 *Liquid Nitrogen*, of such purity that P_0 is not more than 20 torr above barometric pressure. A fresh daily supply is recommended.

7.4 *Nitrogen Gas*—A cylinder of nitrogen gas at least 99.9 % pure.

8. Procedure—Sample Preparation and Degassing

8.1 Select a sample tube of the desired size. A 5-cm³ sample tube is preferred for samples not exceeding about 1 g, to minimize the dead-space. However, a 25-cm³ sample tube may be preferred for finely powdered catalysts, to avoid “bumping” when degassing is started.

8.2 Fill the sample tube with nitrogen or helium, at barometric pressure, after removing air by evacuation. This may be done on the surface area unit, or on a separate piece of equipment.

8.3 Remove the sample tube from the system, cap, and weigh. Record the weight as W_1 .

8.4 Place the catalyst sample, of which the weight is known approximately, into the sample tube. Choose the sample size to provide an estimated total sample surface area of 20 to 100 m².

8.5 Attach the sample tube to the apparatus. If other samples are to be run, attach them at this time to the other ports.

8.6 Open the S valves where there are samples.

8.7 Slowly open the V valve, monitoring the rate of pressure decrease to avoid too high a rate, which could lead to excessive fluidization of powdered samples.

8.7.1 It may be necessary to close the V valve system periodically to protect the vacuum pump from exposure to

pressures above 0.1 torr for periods of more than 30 s. Close the valve off for 2 min each time.

8.8 Install a heating mantle or furnace around each sample and raise the temperature to about 300°C (573 K).

NOTE 3—Take special precautions if the moisture content exceeds approximately 5 % to avoid “bumping” of powdered catalyst, and to avoid surface area loss by self-steaming. It is recommended that the heating rate not exceed 100°C(K)/h under these circumstances.

8.9 Continue degassing at about 300°C (573 K) for a minimum of 3 h, at a pressure not to exceed 10⁻³ torr. Overnight degassing is permissible.

NOTE 4—Zeolite-containing catalysts may contain large quantities of water. Pretreatment of the sample in an oven at 400°C in flowing nitrogen for a couple of hours may be desirable.

8.10 Remove the heating mantles, and allow the samples to cool.

8.11 Close the EV valve, if open.

8.12 Close the S valve.

8.13 It is recommended to exercise the option of preliminary degassing on an external unit. In such a case, follow the procedures of 8.4 – 8.11 and then optionally repeat on the surface area unit, except that the supplementary degassing time in 8.9 should not exceed 1 h.

8.14 If it is desired to weigh the sample after preliminary degassing on an external unit, backfill with the same gas used in 8.2 to barometric pressure. Close the S valve. Otherwise, use the weight obtained in 10.18 and omit 8.15.

8.15 Detach the sample tube from the apparatus, recap with the stopper used previously, and weigh. Record the weight as W_2 .

8.16 Attach the sample tube, uncapped, to an analysis port on the measurement apparatus. Remove the backfilled gas by evacuation to less than 10⁻⁴ torr at room temperature.

9. Procedure—Dead-Space Determination

9.1 From this point on, each sample being tested for micropore volume and surface area must be run on an individual basis. Thus, each Step 9.2 – 10.17 must be carried out separately for each tube in test.

9.2 The “dead-space” is the void volume of the charged sample tube, including the volume within the S valve, when the tube is immersed in liquid nitrogen to the proper depth.

NOTE 5—The dead-space may be determined after the nitrogen adsorption, if more convenient, so long as adequate degassing precedes its determination. In that case, replace the liquid nitrogen bath after 10.14 before proceeding with 9.3 – 9.9. Then, remove the Dewar flask before carrying out 10.15 – 10.17.

9.3 Place a Dewar flask of liquid nitrogen around the sample and adjust the liquid level to a fixed point on the sample tube. Maintain this level throughout the test.

NOTE 6—Some modern commercial instruments do not require manual maintenance or readjusting of the level of liquid nitrogen during the analysis. Follow the manufacturer’s recommendations for operating the particular instrument used.

9.4 Zero the pressure gauge.

⁴ *Reagent Chemicals, American Chemical Society Specifications*, American Chemical Society, Washington, DC. For suggestions on the testing of reagents not listed by the American Chemical Society, see *Analar Standards for Laboratory Chemicals*, BDH Ltd., Poole, Dorset, U.K., and the *United States Pharmacopeia and National Formulary*, U.S. Pharmacopeial Convention, Inc. (USPC), Rockville, MD.

9.5 Admit the helium gas into the system to a pressure of 600 to 900 torr by carefully opening the *H* valve. With *H* valve closed, record this pressure, P_{H_1} , and the manifold temperature, T_{H_1} .

9.6 Open the *S* valve to admit helium to the sample.

9.7 After about 5 min of equilibration, readjust the liquid nitrogen level, and record the pressure, P_{H_2} , and the manifold temperature, T_{H_2} .

9.8 Repeat 9.5 – 9.7 for each sample cell attached to the manifold.

9.9 Open all *S* valves; then slowly open the *V* valve to remove the helium gas.

9.10 When a pressure less than 0.01 torr has been attained, close the *S* valve. This operation should take 5 to 10 min.

10. Procedure—Nitrogen Adsorption

10.1 Close the *V* valve and open the *EV* valve. (The extra volume bulb should be thermostatted at a particular temperature, a few degrees above ambient.)

10.2 Recheck the zero setting of the pressure gage.

10.3 Admit nitrogen gas, and record the pressure as $P_1(1)$ (torr) and the temperature as $T_1'(1)$ (degrees Celsius). It is desirable, but not necessary, to choose $P_1(1)$ such that the first equilibrium adsorption pressure, $P_2(1)$ will be about 8 to 15 torr, or $P_2(1)/P_0$ of about 0.01 to 0.02. Record $T_x'(1)$. Close the *EV* valve.

10.4 Open the *S* valve to admit nitrogen to the catalyst.

10.5 Allow sufficient time for equilibration, readjusting the liquid nitrogen level when necessary. Equilibrium shall be considered as attained when the pressure change is no more than 0.1 torr in 5 min. If the equilibrium pressure is too low, open *EV* valve and re-equilibrate the system.

10.6 Record the equilibrium pressure as $P_2(1)$, and manifold temperature $T_2'(1)$.

10.7 Record the liquid nitrogen temperature $T_s(1)$ or the nitrogen vapor pressure $P_0(1)$.

10.8 Close the *S* valve and close the *EV* valve; then admit nitrogen gas to increase the pressure as needed (usually by 100 to 200 torr), depending upon surface area. The increments should be small (usually smaller than 100 to 200 torr) when P/P_0 is less than 0.1. Record the pressure, $P_1(2)$, and the temperature, $T_1'(2)$.

10.9 Open the *S* valve to admit the new increment of nitrogen to the catalyst.

10.10 Allow sufficient time for equilibration, readjusting the liquid nitrogen level as necessary. The criterion for equilibrium is defined in 10.5.

10.11 Record the equilibrium pressure as $P_2(2)$, and record $T_2'(2)$.

10.12 Again record $T_s(2)$ or $P_0(2)$.

10.13 Repeat 10.8 – 10.12 until there are at least four points in the linear BET range and at least four points in the linear *t*-plot range.

10.13.1 The linear BET range will normally fall between P/P_0 values of 0.05 to about 0.25, but will be found between 0.01 and 0.09 as zeolite levels increase. A negative intercept means that a lower range should be chosen; it may be necessary to take the BET line through the origin (that is, high “*c*” constant).

10.13.2 The linear *t*-plot range will be found between $P/P_0 = 0.03$ ($t = 3$) and $P/P_0 = 0.44$ ($t = 6$). The range is often narrow, between $P/P_0 = 0.056$ ($t = 3.3$) and $P/P_0 = 0.4$ ($t = 5.7$).

NOTE 7—For an introduction to BET and *t*-plot theories and applications, see Lowell and Shields,⁵ Lippens and de Boer,⁶ and Johnson.⁷

10.14 Slowly open the *V* valve, remove the Dewar flask, and allow the sample tube to warm to room temperature.

10.15 If the sample was weighed in 8.15, go to Section 11.

10.16 When frost has disappeared from the sample tube, wipe it dry.

10.17 Backfill the sample tube with the same gas used in 8.2 to about atmospheric pressure. Close the *S* valve.

10.18 Detach the sample tube from the apparatus, recap with the stopper used previously, and weigh. Record the weight as W_2 .

11. Calculations

11.1 Calculate the weight of sample W_s , as follows:

$$W_s = W_2 - W_1 \quad (1)$$

11.2 Calculate the effective void volume of the sample tube, V_s , as follows:

$$V_s = \frac{T_s V_d}{P_{H_2}} \left[\left(\frac{P_{H_1}}{T_{H_1} + 273.2} \right) - \left(\frac{P_{H_2}}{T_{H_2} + 273.2} \right) \right] \quad (2)$$

11.3 For each point, $i = 1, 2 \dots n$, the following measurements will have been recorded:

11.3.1 For pressures $P_1(i)$ and $P_2(i)$, see 6.1.3, 10.3, 10.6, 10.8, 10.11, and 10.13.

11.3.2 For vapor pressures, $P_0(i)$, or liquid nitrogen temperatures, $T_s(i)$, see 6.7, 10.7, 10.12.

11.3.2.1 If $P_0(i)$ is not measured directly, the values of $T_s(i)$ can be converted to $P_0(i)$ for $76 \leq T_s(i) \leq 80$ kelvins: In $(P_0(i)/25492.78) = [A_X + B_X^{3/2} + C_X^3 + D_X^6]/(i - x)$,

where:

$$X = (1 - T_s/126.2),$$

$$A = 6.09676,$$

$$B = 1.1367,$$

$$C = 1.04072, \text{ and}$$

$$D = -1.93306.$$

(See Reid, Prausnitz, and Poling.⁸)

11.3.3 For manifold temperatures $T_1'(i)$ and $T_2'(i)$, see 6.6, 10.3, 10.8, 10.11, and 10.13.

⁵ Lowell, S., and Shields, J. E., “Powder Surface Area and Porosity,” 3rd Ed., Chapman and Hall, New York, 1991.

⁶ Lippens, B. C., and de Boer, J. H., *J Catal*, Vol 4, 1965, p. 319.

⁷ Johnson, M. F. L., *J Catal*, Vol 52, 1978, p. 425.

⁸ Reid, R. C., Prausnitz, J. M., and Poling, B. E., *The Properties of Gases and Liquids*, 4th Ed., McGraw-Hill, New York, 1987.

11.3.4 If valve *EV* was closed, $V_x = 0$. See 6.1.7.

11.4 For each point, $i = 1, 2 \dots n$, calculate the following:

11.4.1 $X(i)$ = relative pressure = $P_2(i)/P_0(i)$.

11.4.2 Manifold temperature in Kelvin:

$$T_1(i) = T_1'(i) + 273.2 \quad (3)$$

$$T_2(i) = T_2'(i) + 273.2$$

11.4.3 Volume of N_2 in manifold + extra volume with valve *S* closed to catalyst (cm^3 STP):

$$V_1(i) = \left(\frac{V_d}{T_1(i)} + \frac{V_x}{T_x(i)} \right) \left(\frac{P_1(i) \times 273.2}{760} \right) \quad (4)$$

11.4.4 Volume of N_2 in manifold + extra volume with valve *S* open to catalyst (cm^3 STP):

$$V_2(i) = \left(\frac{V_d}{T_2(i)} + \frac{V_x}{T_x(i)} \right) \left(\frac{P_2(i) \times 273.2}{760} \right) \quad (5)$$

See 6.1.1 and 6.1.7 for V_d and V_x .

11.4.5 Total inventory of nitrogen in the system (cm^3 STP):

$$V_i(i) = V_i(i-1) + V_1(i) - V_2(i-1) \quad (6)$$

$$V_i(0) = 0$$

11.4.6 Volume of nitrogen in the dead-space (cm^3 STP):

$$V_{ds}(i) = 273.2 \frac{(V_s)P_2(i)}{760 T_s} \left(1 + \frac{0.05P_2(i)}{760} \right) \quad (7)$$

See 11.2 for V_s .

11.4.6.1 The deviation from the perfect gas law of nitrogen at liquid nitrogen temperature is 5 % at one atmosphere, proportional to pressure.

11.4.7 The quantity of gas adsorbed ($\text{cm}^3\text{STP/g}$):

$$V_a(i) = \frac{V_i(i) - V_2(i) - V_{ds}(i)}{W_s} \quad (8)$$

See 11.1 for W_s .

11.4.8 The BET function, when $X(i) \geq 0.04$:

$$BET(i) = \left(\frac{X(i)}{V_a(i)} \right) \left(\frac{1}{(1 - X(i))} \right) \quad (9)$$

11.5 Construct the BET plot, by plotting $X(i)$ as the abscissa, $BET(i)$ as the ordinate.

11.6 Using a straightedge, draw a line through the linear region. Deviations from the straight line, if any, should be below the line at low $X(i)$, above the line at high $X(i)$, but not apparent within the linear region.

NOTE 8—As zeolite content increases, the range of linearity of the BET equation shifts to lower values, and may appear to extend to the origin. A negative intercept can be eliminated by dropping the point having the highest $X(i)$ value.

11.7 Determine the slope S_B and intercept I_B of the straight line.

11.7.1 This is preferably done by a least squares calculation, choosing only those points which fall within the linear region. It will generally be clear by inspection of the BET plot which points to choose to define the straight line. When the proper choice has been made, deviations of individual points from the straight line should not exceed about 0.6 % of the value of the ordinate. A deviation as large as 1 % is excessive.

11.8 Calculate V_m , the volume of adsorbate required to complete one statistical monolayer (cm^3 STP/g):

$$V_m = \frac{1}{S_B + I_B} \quad (10)$$

11.9 BET surface area = $(4.353)(V_m)$. This assumes a value of 16.2 \AA^2 ($1 \text{ \AA} = 0.1 \text{ nm}$) for the cross-sectional area of a nitrogen molecule, and a molar volume for N_2 of 22.41 L.

11.10 For each point, $i = 1, 2, \dots, n$, calculate

$$t(i) = \left(\frac{13.99}{0.034 - \log X(i)} \right)^{1/2} \quad (11)$$

11.11 Construct the t -plot, by plotting $t(i)$ as the abscissa, $V_a(i)$ as the ordinate.

11.12 Using a straightedge, draw a line through the linear region. Deviations from the straight line, if any, should be below the line at low $t(i)$, above the line at high $t(i)$.

11.13 Determine the slope S_t and intercept I_t of the straight line. This is preferably done by a least squares calculation.

$$11.14 \text{ Calculate the } t\text{-area} = (S_t) \left(\frac{15.47}{0.975} \right)$$

11.14.1 The 0.975 factor is applicable to oxide type catalysts. Its use will generally provide excellent agreement between t -area and BET area in the absence of zeolite, or other materials containing micropores.

11.15 Calculate micropore volume = (I_t) (0.001547).

11.16 Calculate zeolite area = $(BET\text{-area}) - (t\text{-area})$.

11.17 Determine that the micropore volume and zeolite area correspond to each other, by fit to the plot generated from calibrating materials.

NOTE 9—See Johnson⁷ for a plot generated from calibrating materials containing Y zeolites. Plots for other microporous materials can be derived using similar procedures.

NOTE 10—This equation was obtained using deBoer's P/P_0 versus t data and applying it to Harkins' adsorption equations: (1) Harkins and Jura⁹ and (2) deBoer, et al.¹⁰

12. Report

12.1 Report the following information:

12.1.1 The micropore volume to three significant figures,

12.1.2 The zeolite area, if calculated to three significant figures, and

12.1.3 The report shall include pretreatment and outgassing temperatures.

13. Precision and Bias¹¹

13.1 *Test Program*—An interlaboratory study was conducted in which the zeolite area was measured in three separate test materials in nine separate laboratories. Practice E691, modified for nonuniform data sets, was followed for the data reduction. Analysis details are in the research report.

⁹ Harkins, W. D., and Jura, G., *Journal of American Chemical Society*, Vol 66, 1944, p. 1366.

¹⁰ deBoer, J. H., et al., *Journal of Colloid Interface Science*, Vol 21, 1966 p. 405.

¹¹ Supporting data are available on loan from ASTM International Headquarters. Request RR:D32-1009.

13.2 *Precision*—Pairs of test results of zeolite areas obtained by a procedure similar to that described in the study are expected to differ in absolute value by less than 2.77 S, where 2.77 S is the 95 % probability limit on the difference between two test results, and S is the appropriate estimate of standard deviation. Definitions and usage are given in Terminology E456 and Practice E177, respectively.

Test Result (Consensus), m ² /g	95 % Repeatability Limit (Within Laboratory, m ² /g (%))	95 % Reproducibility Limit (Between Laboratories), m ² /g (%)
87.27	4.69 (5.4)	31.85 (36.5)
136.04	7.27 (5.3)	31.99 (23.5)
173.78	8.77 (5.0)	25.14 (14.5)

13.3 A precision statement for micropore volume is being developed.

13.4 *Bias*—This test method is without known bias.

14. Keywords

14.1 catalyst; micropore volume; nitrogen adsorption; *t*-plot; zeolite; zeolite area

ASTM International takes no position respecting the validity of any patent rights asserted in connection with any item mentioned in this standard. Users of this standard are expressly advised that determination of the validity of any such patent rights, and the risk of infringement of such rights, are entirely their own responsibility.

This standard is subject to revision at any time by the responsible technical committee and must be reviewed every five years and if not revised, either reapproved or withdrawn. Your comments are invited either for revision of this standard or for additional standards and should be addressed to ASTM International Headquarters. Your comments will receive careful consideration at a meeting of the responsible technical committee, which you may attend. If you feel that your comments have not received a fair hearing you should make your views known to the ASTM Committee on Standards, at the address shown below.

This standard is copyrighted by ASTM International, 100 Barr Harbor Drive, PO Box C700, West Conshohocken, PA 19428-2959, United States. Individual reprints (single or multiple copies) of this standard may be obtained by contacting ASTM at the above address or at 610-832-9585 (phone), 610-832-9555 (fax), or service@astm.org (e-mail); or through the ASTM website (www.astm.org). Permission rights to photocopy the standard may also be secured from the Copyright Clearance Center, 222 Rosewood Drive, Danvers, MA 01923, Tel: (978) 646-2600; http://www.copyright.com/