



Standard Practice for Fluorescent Ultraviolet (UV) Lamp Apparatus Exposure of Plastics¹

This standard is issued under the fixed designation D4329; the number immediately following the designation indicates the year of original adoption or, in the case of revision, the year of last revision. A number in parentheses indicates the year of last reapproval. A superscript epsilon (ϵ) indicates an editorial change since the last revision or reapproval.

1. Scope*

1.1 This practice covers specific procedures and test conditions that are applicable for fluorescent UV exposure of plastics conducted in accordance with Practices [G151](#) and [G154](#). This practice also covers the preparation of test specimens, the test conditions best suited for plastics, and the evaluation of test results.

1.2 The values stated in SI units are to be regarded as standard. The values given in parentheses are for information only.

1.3 *This standard does not purport to address all of the safety concerns, if any, associated with its use. It is the responsibility of the user of this standard to establish appropriate safety and health practices and determine the applicability of regulatory limitations prior to use.*

NOTE 1—This practice is technically similar to ISO 4892-3.

2. Referenced Documents

2.1 *ASTM Standards:*²

- [D5870 Practice for Calculating Property Retention Index of Plastics](#)
- [E691 Practice for Conducting an Interlaboratory Study to Determine the Precision of a Test Method](#)
- [G113 Terminology Relating to Natural and Artificial Weathering Tests of Nonmetallic Materials](#)
- [G141 Guide for Addressing Variability in Exposure Testing of Nonmetallic Materials](#)
- [G147 Practice for Conditioning and Handling of Nonmetallic Materials for Natural and Artificial Weathering Tests](#)
- [G151 Practice for Exposing Nonmetallic Materials in Accelerated Test Devices that Use Laboratory Light Sources](#)
- [G154 Practice for Operating Fluorescent Ultraviolet \(UV\)](#)

¹ This practice is under the jurisdiction of ASTM Committee [D20](#) on Plastics and is the direct responsibility of Subcommittee [D20.50](#) on Durability of Plastics.

Current edition approved July 15, 2013. Published August 2013. Originally approved in 1984. Last previous edition approved in 2005 as D4329 - 05. DOI: 10.1520/D4329-13.

² For referenced ASTM standards, visit the ASTM website, www.astm.org, or contact ASTM Customer Service at service@astm.org. For *Annual Book of ASTM Standards* volume information, refer to the standard's Document Summary page on the ASTM website.

[Lamp Apparatus for Exposure of Nonmetallic Materials](#)
[G169 Guide for Application of Basic Statistical Methods to Weathering Tests](#)

[G177 Tables for Reference Solar Ultraviolet Spectral Distributions: Hemispherical on 37° Tilted Surface](#)

2.2 *ISO Standard:*³

[ISO 4892-3 Plastics—Methods of Exposure to Laboratory Light Sources—Part 3, Fluorescent UV Lamps](#)

2.3 *SAE Standard:*⁴

[SAE J2020 Accelerated Exposure of Automotive Exterior Materials Using a Fluorescent UV and Condensation Apparatus](#)

3. Terminology

3.1 The definitions in Terminology [G113](#) are applicable to this practice.

4. Significance and Use

4.1 The ability of a plastic material to resist deterioration of its electrical, mechanical, and optical properties caused by exposure to light, heat, and water can be very significant for many applications. This practice is intended to induce property changes associated with end-use conditions, including the effects of ultraviolet solar irradiance, moisture, and heat. The exposure used in this practice is not intended to simulate the deterioration caused by localized weather phenomena, such as, atmospheric pollution, biological attack, and saltwater exposure. (**Warning**—Variation in results may be expected when operating conditions are varied within the accepted limits of this practice. Therefore, no reference to the use of this practice should be made unless accompanied by a report prepared in accordance with Section [8](#) that describes the specific operating conditions used. Refer to Practice [G151](#) for detailed information on the caveats applicable to use of results obtained in accordance with this practice.)

NOTE 2—Additional information on sources of variability and on strategies for addressing variability in the design, execution, and data analysis of laboratory-accelerated exposure tests is found in Guide [G141](#).

³ Available from American National Standards Institute (ANSI), 25 W. 43rd St., 4th Floor, New York, NY 10036, <http://www.ansi.org>.

⁴ Available from SAE International (SAE), 400 Commonwealth Dr., Warrendale, PA 15096-0001, <http://www.sae.org>.

*A Summary of Changes section appears at the end of this standard

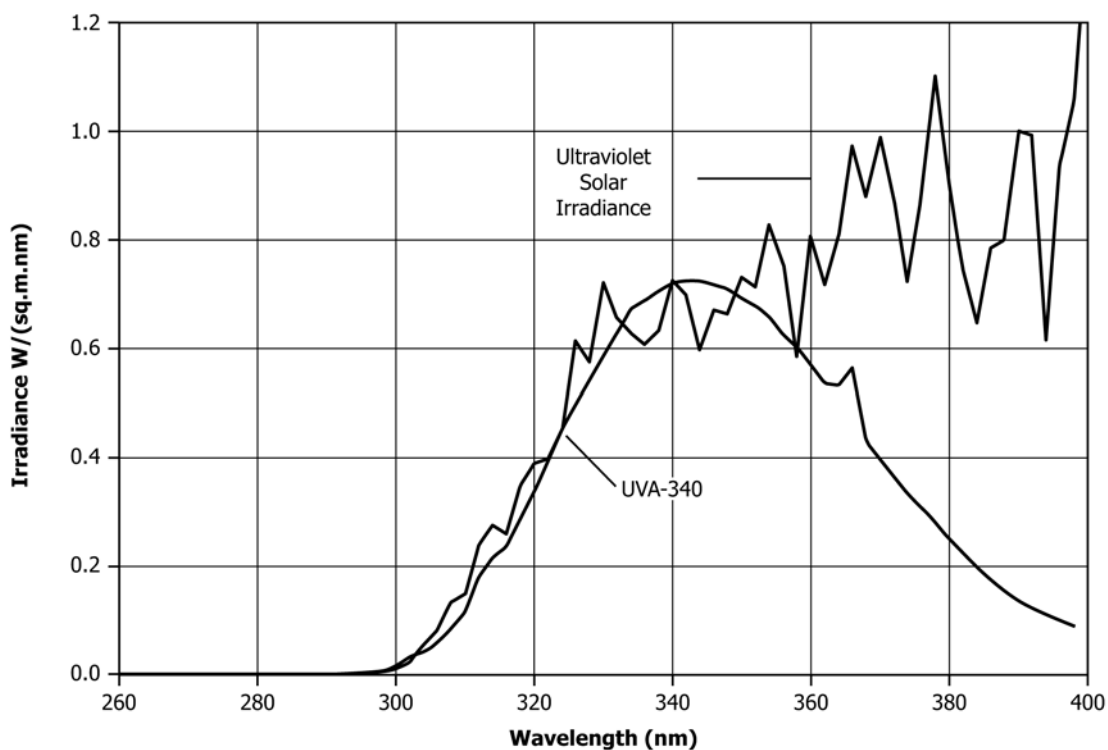

FIG. 1 Representative Spectral Power Distribution of UVA-340 Fluorescent Lamps

4.2 Reproducibility of test results between laboratories has been shown to be good when the stability of materials is evaluated in terms of performance ranking compared to other materials or to a control.^{5,6} Therefore, exposure of a similar material of known performance (a control) at the same time as the test materials is strongly recommended. It is recommended that at least three replicates of each material be exposed to allow for statistical evaluation of results.

4.3 Test results will depend upon the care that is taken to operate the equipment in accordance with Practice G154. Significant factors include regulation of line voltage, temperature of the room in which the device operates, temperature control, and condition and age of the lamp.

5. Apparatus

5.1 Use of fluorescent UV apparatus that conforms to the requirements defined in Practices G151 and G154 is required to conform to this practice.

5.2 Unless otherwise specified, the spectral power distribution of the fluorescent UV lamp shall conform to the requirements in Practice G154 for a UVA 340 lamp. Fig. 1 is a spectral irradiance plot for a typical UVA-340 lamp and benchmark solar radiation.

NOTE 3—The source of the ultraviolet solar irradiance data in Fig. 1 is the Standard G177 standard solar spectrum.

5.3 Test Apparatus Location:

5.3.1 Locate the apparatus in an area maintained between 18 and 27°C (65 and 80°F). Control of ambient temperature is particularly critical when one apparatus is stacked above another, because the heat generated from the lower unit can interfere with the operation of the units above.

5.3.2 Place the apparatus at least 300 mm from walls or other apparatus. Do not place the apparatus near a heat source such as an oven.

5.3.3 Ventilate the room in which the apparatus is located to remove heat and moisture.

6. Test Specimen

6.1 The size and shape of specimens to be exposed will be determined by the specifications of the particular test method used to evaluate the effects of the exposure on the specimens; the test method shall be determined by the parties concerned. Where practical, it is recommended that specimens be sized to fit specimen holders and racks supplied with the exposure apparatus. Unless supplied with a specific backing as an integral part of the test, specimens shall be mounted so that only the minimum specimen area required for support by the holder shall be covered. This unexposed surface must not be used as part of the test area.

6.2 For specimens of insulating materials, such as foams, quickly check the specimens during the condensation period to verify that visible condensation is occurring on the specimens. Perform this visual check once per week at least one hour after the start of condensation.

⁵ Fischer, R., "Results of Round Robin Studies of Light- and Water-Exposure Standard Practices," *Accelerated and Outdoor Durability Testing of Organic Materials*, ASTM STP 1202, Warren D. Ketola and Douglas Grossman, eds., American Society for Testing and Materials, Philadelphia, 1993.

⁶ Ketola, W., and Fischer, R., "Characterization and Use of Reference Materials in Accelerated Durability Tests," *VAMAS Technical Report No. 30*, available from NIST, Gaithersburg, MD.

TABLE 1 Operational Fluctuations on Exposure Conditions

Parameter	Maximum Allowable Deviation from the Set Point at the Control Point Indicated by the Readout of the Calibrated Control Sensor During Equilibrium Operation
Black Panel Temperature	±2.5°C
Irradiance (monitored at 340 nm or monitored at 310 nm)	±0.02 W/(m ² · nm)
Irradiance (monitored at 270-700 nm)	±0.5 W/m ²

NOTE 4—If condensation is not occurring, the most likely cause involves inadequate room-air cooling; (1) the laboratory temperature is too high; (2) condensation temperature is set too low, or too close to room temperature; (3) thick specimens of insulating material may be preventing the room-air cooling necessary for condensation. For example, a 25-mm thick wood specimen may exhibit poor condensation with a condensation set point of 40°C and a lab temperature of 30°C; or (4) improper specimen mounting is allowing vapor to escape from the chamber.

6.3 To provide rigidity, attach flexible specimens to a backing panel made of aluminum, 0.635 mm (0.025 in.) thick. Suggested aluminum alloys are 5052, 6061, or 3003.

6.4 Seal any holes in specimens larger than 2 mm and any openings larger than 1 mm around irregularly shaped specimens to prevent loss of water vapor. Attach porous specimens to a solid backing such as aluminum that can act as a vapor barrier.

6.5 Unless otherwise specified, expose at least three replicate specimens of each test and control material.

6.6 Follow the procedures described in Practice G147 for identification, conditioning, and handling of specimens of test, control, and reference materials prior to, during, and after exposure.

6.7 Do not mask the face of a specimen for the purpose of showing on one panel the effects of various exposure times. Misleading results may be obtained by this method, since the masked portion of the specimen is still exposed to temperature and humidity cycles that in many cases will affect results.

6.8 Since the thickness of a specimen may markedly affect the results, thickness of test and control specimens shall be within ±10 % of the nominal dimensions.

NOTE 5—This is especially important when mechanical properties are being investigated.

6.9 Retain a supply of unexposed file specimens of all materials evaluated.

6.9.1 When destructive tests are run, ensure that sufficient file specimens are retained so that the property of interest can be determined on unexposed file specimens each time exposed materials are evaluated.

6.10 Specimens should not be removed from the exposure apparatus for more than 24 h and then returned for additional tests, since this does not produce the same results on all materials as tests run without this type of interruption. When specimens are removed from the exposure apparatus for 24 h or more and then returned for additional exposure, report the elapsed time as noted in accordance with Section 9.

NOTE 6—Since the stability of the file specimen may also be time-dependent, users are cautioned that over prolonged exposure periods, or where small differences in the order of acceptable limits are anticipated, comparison of exposed specimens with the file specimen may not be valid. Instrumental measurements are recommended whenever possible.

7. Procedure

7.1 When the test and control specimens do not completely fill the specimen racks, fill all empty spaces with blank panels to maintain the test conditions within the chamber.

7.2 Unless otherwise specified, program the device to one of the following test cycles. Operate the device continuously.

7.2.1 Cycle A:

Typical Irradiance at 340 nm is 0.89 W/(m² · nm)
 8 h UV with uninsulated black panel temperature controlled at 60°C
 4 h condensation with uninsulated black panel temperature controlled at 50°C
 (Used for most general applications)

7.2.2 Cycle B:

Typical Irradiance at 340 nm is 0.77 W/(m² · nm)
 8 h UV with uninsulated black panel temperature controlled at 70°C
 4 h condensation with uninsulated black panel temperature controlled at 50°C
 (Typically used for automotive applications) Note: Cycle B is equivalent to the exposure test cycle specified in SAE J2020.

7.2.3 Cycle C:

Typical Irradiance at 340 nm is 0.83 W/(m² · nm)
 8 h UV with uninsulated black panel temperature controlled at 50°C
 4 h condensation with uninsulated black panel temperature controlled at 50°C
 (Typically used for some plastic building products)

NOTE 7—Unless otherwise specified, operate the apparatus to maintain the operational fluctuations specified in Table 1 for the parameters in Cycles A, B, and C. If the actual operating conditions do not agree with the machine settings after the equipment has stabilized, discontinue the test and correct the cause of the disagreement before continuing.

7.3 Practice G154 lists several other exposure cycles that are used for fluorescent UV exposures of nonmetallic materials. Obtain mutual agreement between all concerned parties for the specific exposure cycle used.

7.4 In order to minimize any effects from temperature or UV light variation, reposition the specimens as follows. Fig. 2 shows a diagram of the specimen repositioning.

7.4.1 Reposition the specimen holders horizontally to ensure that each specimen spends the same amount of exposure time in each horizontal position by (1) moving the two extreme right-hand holders to the far left of the exposure area, and (2) sliding the remaining holders to the right.

7.4.2 Reposition the specimens vertically so that each specimen spends the same amount of exposure time in each vertical position within the specimen holder. For instance, if two specimens are stacked vertically in each holder, then the top and bottom specimens should switch places halfway through the test. If four specimens are stacked vertically, then the specimens should be repositioned vertically three times during the test.

NOTE 8—Guidance can be found in ASTM G151 on specimen repositioning or other means of ensuring equal radiant exposure on all

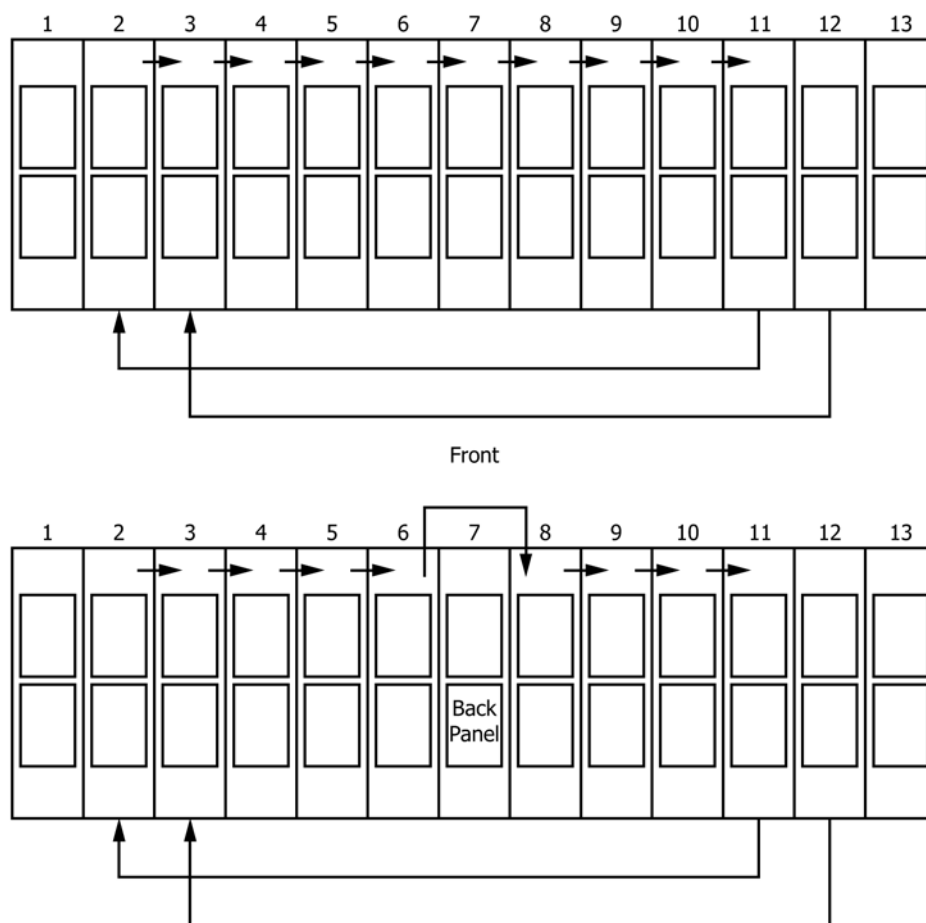

FIG. 2 Horizontal Specimen Holder Repositioning

specimens or compensation for differences in irradiance within the exposure chamber.

7.5 *Water Purity*—The purity of water used for specimen spray is very important. Follow the purity requirements in Practice G151 for water sprayed on specimen surfaces. It is recommended that deionized water be used for water used to produce condensation.

7.6 It is recommended that a control material be exposed at the same time as the test specimens for comparison purposes, if performance comparisons are not being made between the test materials themselves. All concerned parties must agree on the control material used.

7.6.1 Identification of any control specimen used shall accompany the report.

8. Periods of Exposure and Evaluation of Test Results

8.1 In most cases, periodic evaluation of test and control materials is necessary to determine the variation in magnitude and direction of property change as a function of exposure time or radiant exposure.

8.2 The time or radiant exposure necessary to produce a defined change in a material property can be used to evaluate or rank the stability of materials. This method is preferred over evaluating materials after an arbitrary exposure time or radiant exposure.

8.2.1 Exposure to an arbitrary time or radiant exposure may be used for the purpose of a specific test if agreed upon between the parties concerned or if required for conformance to a particular specification. When a single exposure period is used, select a time or radiant exposure that will produce the largest performance differences between the test materials or between the test material and the control material.

8.2.2 The minimum exposure time used shall be that necessary to produce a substantial change in the property of interest for the least stable material being evaluated. An exposure time that produces a significant change in one type of material cannot be assumed to be applicable to other types of materials.

8.2.3 The relation between time to failure in an exposure conducted in accordance with this practice and service life in an outdoor environment requires determination of a valid acceleration factor. Do not use arbitrary acceleration factors relating time in an exposure conducted in accordance with this practice and time in an outdoor environment because they can give erroneous information. The acceleration factor is material-dependent and is only valid if it is based on data from a sufficient number of separate exterior and laboratory-accelerated exposures so that results used to relate times to failure in each exposure can be analyzed using statistical methods.

NOTE 9—An example of a statistical analysis using multiple-laboratory and exterior exposures to calculate an acceleration factor is described by Simms.⁷ See Practice **G151** for more information and additional cautions about the use of acceleration factors.

8.3 After each exposure increment, evaluate or rate changes in exposed test specimens in accordance with applicable ASTM test methods.

NOTE 10—For some materials, changes may continue after the specimen has been removed from the exposure apparatus. Measurements (visual or instrumental) should be made within a standardized time period or as agreed upon between the interested parties. The standardized time period needs to consider conditioning prior to testing.

8.4 Use of results from exposures conducted in accordance with this practice in specifications:

8.4.1 If a standard or specification for general use requires a definite property level after a specific time or radiant exposure in an exposure test conducted in accordance with this practice, base the specified property level on results from round-robin experiments run to determine the test reproducibility from the exposure and property measurement procedures. Conduct these round robins in accordance with Practice **E691** and include a statistically representative sample of all laboratories or organizations who would normally conduct the exposure and property measurement.

8.4.2 If a standard or specification for use between two or three parties requires a definite property level after a specific time or radiant exposure in an exposure test conducted in accordance with this practice, base the specified property level on two independent experiments run in each laboratory to determine the reproducibility for the exposure and property measurement process. The reproducibility of the exposure/property measurement process is then used to determine the minimum level of property after the exposure that is mutually agreeable to all parties.

8.4.3 When reproducibility in results from an exposure test conducted in accordance with this practice has not been established through round-robin testing, specify performance requirements for materials in terms of comparison (ranked) to a control material. All specimens shall be exposed simultaneously in the same device. All concerned parties must agree on the specific control material used.

8.4.3.1 Conduct analysis of variance to determine whether any differences between test materials and control materials is statistically significant. Expose replicates of the test specimen and the control specimen so that statistically significant performance differences can be determined

NOTE 11—Fischer illustrates use of rank comparison between test and

control materials in specifications.⁸

NOTE 12—Guide **G169** includes examples showing use of analysis of variance to compare materials.

9. Report

9.1 Report the following information:

9.1.1 Type and model of exposure device.

9.1.2 For non-irradiance controlled devices, report the age of fluorescent lamps used at the start of the exposure, and whether any lamps were changed during the period of exposure.

9.1.3 If required, irradiance in $W/(m^2 \cdot nm)$ at 340 nm, or radiant exposure in $J/(m^2 \cdot nm)$ at 340 nm. For measurements over a spectral range, irradiance in W/m^2 or radiant exposure in J/m^2 and the wavelength region in which measurements were made.

9.1.3.1 Do not report irradiance or radiant exposure unless direct measurement of irradiance was made during the exposure.

9.1.4 Elapsed exposure time.

9.1.5 Light- and dark-water condensation or spray cycle employed.

9.1.6 Operating black panel temperature.

9.1.7 If water spray is used, total solids and silica level of water used for specimen spray (if above limits specified in Practice **G151**).

9.1.8 If used, specimen repositioning or other means of ensuring equal radiant exposure on all specimens or compensation for differences in irradiance within the exposure chamber.

9.1.9 Results of property tests. Calculate retention of characteristic property in accordance with Practice **D5870** when it is reported.

10. Precision and Bias

10.1 *Precision*—The repeatability and reproducibility of results obtained in exposures conducted in accordance with this practice will vary with the materials being tested, the material property being measured, and the specific test conditions and cycles that are used. It is essential to determine reproducibility of the exposure/property measurement process when using the results from exposures conducted in accordance with this practice in product specifications.

10.2 *Bias*—Bias cannot be determined because no acceptable standard weathering reference materials are available.

11. Keywords

11.1 degradation; exposure; fluorescent UV; light exposure; ultraviolet

⁸ Fischer, R., Ketola, W., "Impact of Research on Development of ASTM Durability Testing Standards," *Durability Testing of Non-Metallic Materials, ASTM STP 1294*, Robert Herling, ed., American Society for Testing and Materials, Philadelphia, 1995.

⁷ Simms, J.A., *Journal of Coatings Technology*, Vol 50, 1987, pp. 45–53.

SUMMARY OF CHANGES

Committee D20 has identified the location of selected changes to this standard since the last issue (D4329 – 05) that may impact the use of this standard. (July 15, 2013)

- (1) Added “Ultraviolet (UV) Lamp Apparatus” to title.
- (2) Added the word “to” to 1.2.
- (3) Replaced “sunlight” with “ultraviolet solar irradiance” in 4.1.
- (4) Changed Section 8 to Section 9 in 4.1.
- (5) Editorially revised Note 3 “sunlight” to “ultraviolet solar irradiance”.
- (6) Revised 5.3 to change “Test Chamber” to “Test Apparatus.”
- (7) Revised 6.2 and added Note 4.
- (8) Added irradiances in the exposure cycle in 7.2.1 to 7.2.3.
- (9) Added new explanatory Note 7 to see ASTM G154 for operational fluctuations.
- (10) Revised wording addressing specimen repositioning in 7.4.1.
- (11) Added new explanatory Note 8 to see ASTM G151 for guidance on specimen repositioning.
- (12) Renumbered Notes 4-9 to 5-12.
- (13) Added “For non-irradiance controlled devices, report the” to 9.1.2.
- (14) Editorially revised 9.1.3 to read $W/(m^2 \cdot nm)$.
- (15) Removed old 9.1.7: “Type of spray nozzle, if used.”
- (16) Editorially changed “compensating” to “compensation” in 9.1.8.
- (17) Editorially changed “sunlight” in Fig. 1 to “ultraviolet solar irradiance”

ASTM International takes no position respecting the validity of any patent rights asserted in connection with any item mentioned in this standard. Users of this standard are expressly advised that determination of the validity of any such patent rights, and the risk of infringement of such rights, are entirely their own responsibility.

This standard is subject to revision at any time by the responsible technical committee and must be reviewed every five years and if not revised, either reapproved or withdrawn. Your comments are invited either for revision of this standard or for additional standards and should be addressed to ASTM International Headquarters. Your comments will receive careful consideration at a meeting of the responsible technical committee, which you may attend. If you feel that your comments have not received a fair hearing you should make your views known to the ASTM Committee on Standards, at the address shown below.

This standard is copyrighted by ASTM International, 100 Barr Harbor Drive, PO Box C700, West Conshohocken, PA 19428-2959, United States. Individual reprints (single or multiple copies) of this standard may be obtained by contacting ASTM at the above address or at 610-832-9585 (phone), 610-832-9555 (fax), or service@astm.org (e-mail); or through the ASTM website (www.astm.org). Permission rights to photocopy the standard may also be secured from the Copyright Clearance Center, 222 Rosewood Drive, Danvers, MA 01923, Tel: (978) 646-2600; <http://www.copyright.com/>