



Standard Test Method for Determining the Leakage Tendencies of Automotive Wheel Bearing Grease Under Accelerated Conditions¹

This standard is issued under the fixed designation D4290; the number immediately following the designation indicates the year of original adoption or, in the case of revision, the year of last revision. A number in parentheses indicates the year of last reapproval. A superscript epsilon (ϵ) indicates an editorial change since the last revision or reapproval.

1. Scope*

1.1 This test method covers a laboratory procedure for evaluating leakage tendencies of wheel bearing greases when tested under prescribed conditions.

1.2 The values stated in SI units are to be regarded as standard. No other units of measurement are included in this standard. The exception is apparatus dimensions, in inches, which are to be regarded as the standard.

1.3 *This standard does not purport to address all of the safety concerns, if any, associated with its use. It is the responsibility of the user of this standard to establish appropriate safety and health practices and determine the applicability of regulatory limitations prior to use.* For specific warning statements, see Section 8.

2. Referenced Documents

- 2.1 *AFBMA Standard*:²
AFBMA Standard 19 1974 (ANSI B.3.19-1975)

3. Terminology

3.1 Definitions:

3.1.1 *lubricant, n*—any material interposed between two surfaces that reduces the friction or wear between them.

3.1.2 *lubricating grease, n*—a semifluid to solid product of a dispersion of a thickener in a liquid lubricant.

3.1.2.1 *Discussion*—The dispersion of the thickener forms a two-phase system and immobilizes the liquid lubricant by surface tension and other physical forces. Other ingredients are commonly included to impart special properties.

3.1.3 *thickener, n*—in *lubricating grease*, a substance composed of finely-divided particles dispersed in a liquid lubricant to form the product's structure.

¹ This test method is under the jurisdiction of ASTM Committee D02 on Petroleum Products, Liquid Fuels, and Lubricants and is the direct responsibility of Subcommittee D02.G0.05 on Functional Tests - Temperature.

Current edition approved April 1, 2015. Published April 2015. Originally approved in 1983. Last previous edition approved in 2012 as D4290 – 07 (2012). DOI: 10.1520/D4290-15.

² Available from American National Standards Institute (ANSI), 25 W. 43rd St., 4th Floor, New York, NY 10036, <http://www.ansi.org>.

3.1.3.1 *Discussion*—The solid thickener can be fibers (such as various metallic soaps) or plates or spheres (such as certain non-soap thickeners) which are insoluble or, at the most, only very slightly soluble in the liquid lubricant. The general requirements are that the solid particles be extremely small, uniformly dispersed, and capable of forming a relatively stable, gel-like structure with the liquid lubricant.

3.2 Definitions of Terms Specific to This Standard:

3.2.1 *automotive wheel bearing grease, n*—a lubricating grease specifically formulated to lubricate automotive wheel bearings at relatively high grease temperatures and bearing speeds.

3.2.2 *leakage, n*—of *wheel bearing grease*, separation and overflow of grease or oil from the bulk grease charge, induced by high temperatures and bearing rotation.

4. Summary of Test Method

4.1 The test grease is distributed in a modified, automobile front wheel hub-spindle-bearings assembly. While the bearings are thrust-loaded to approximately 111 N, the hub is rotated at 1000 rpm and the spindle temperature maintained at 160 °C for 20 h. Leakage of grease or oil, or both, is measured, and the condition of the bearing surface is noted at the end of the test.

5. Significance and Use

5.1 This test method differentiates among wheel bearing greases having distinctly different high-temperature leakage characteristics. It is not the equivalent of longtime service tests.

5.2 This test method has proven to be helpful in screening greases with respect to leakage tendencies for automotive wheel bearing applications.

NOTE 1—It is possible for skilled operators to observe changes in grease characteristics that can occur during the test, such as grease condition. Leakage is reported as a quantitative value, whereas the evaluation of grease condition is subject to differences in personal judgment among operators and cannot be used effectively for quantitative measurements.

6. Apparatus

6.1 Test Assembly (Figs. 1 and 2).

6.1.1 *Custom-made Wheel Hub-Spindle-Bearing Assembly* (Fig. 3).

*A Summary of Changes section appears at the end of this standard

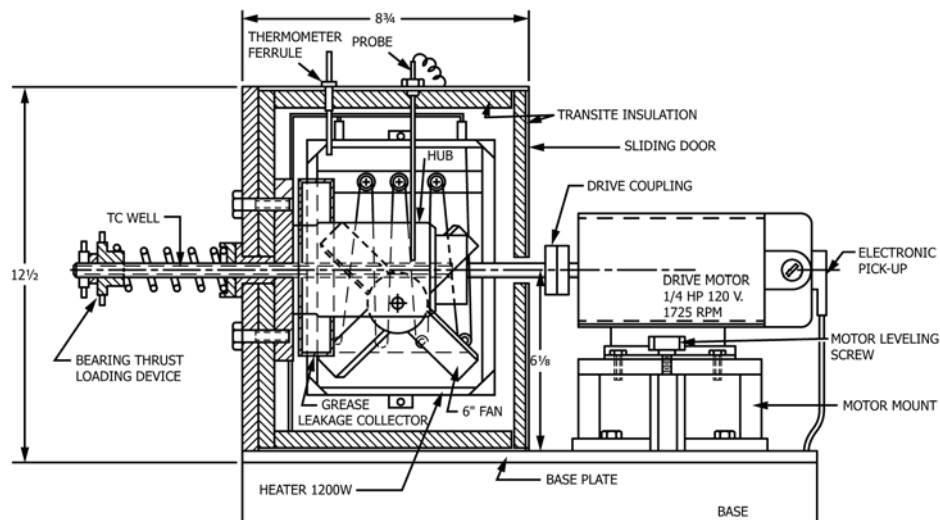

NOTE 1—Caution should be taken when modifying older units since some may still contain asbestos insulation leading to a possible inhalation hazard.

FIG. 1 Wheel Bearing Lubricant Tester (Elevation View)

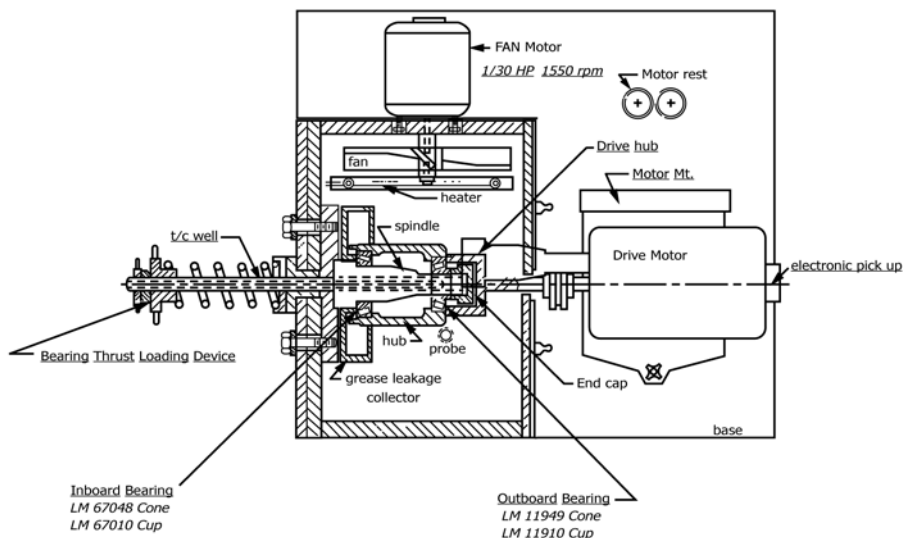

FIG. 2 Wheel Bearing Lubricant Tester (Top View)

6.1.2 *Oven*, electrically heated by 1800 watt heater, thermostatically controlled to maintain spindle temperature at 160 ± 1.5 °C.

6.1.3 *Spindle Drive Motor*, 1/4 hp, 120 volts dc with 1725 rpm speed control for the hub; motor torque is indicated by a meter equipped with an adjustable, automatic cutoff.

6.1.4 *Fan Drive Motor*, 1/30 hp, 120 v dc, 1550 rpm.

6.2 Motor speed, oven temperature, spindle temperature, time cycles and torque are controlled or monitored, or both, by accessory equipment.

6.3 A grease slinger has been added since the original design of the apparatus. Fig. 4 shows the slinger used for the hub of Koehler and Pam apparatus.

NOTE 2—The slinger was developed to prevent grease from creeping along the hub and being slung off past the grease collector. Greases that crept during the test can lead to erroneously low results. Addition of the slinger will not affect the precision data in Section 13 because none of the

round-robin greases exhibited grease creepage.

6.4 *Balance*, having a minimum capacity of 100 g and minimum sensitivity of 0.1 g.

7. Test Bearings

7.1 Use LM67048-LM67010 and LM11949-LM11910 (AF-BMA Standard 19) inboard and outboard bearings, respectively.

8. Reagents and Materials

8.1 *Penmul L460 (previously called Penetone-ECS)*³—(Warning—Combustible. Vapors can be harmful.)

³ The sole source of supply of Penmul L460 (previously called Penetone-ECS) known to the committee at this time is Penetone Corp., 74 Hudson Ave., Tenaply, NJ 07670. If you are aware of alternative suppliers, please provide this information to ASTM International Headquarters. Your comments will receive careful consideration at a meeting of the responsible technical committee,¹ which you may attend.

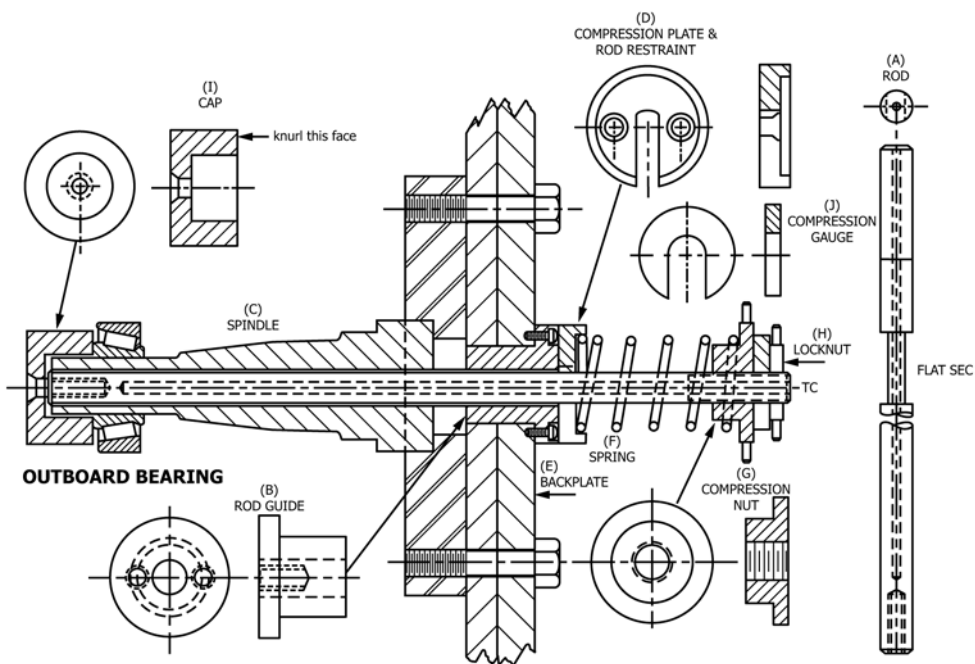

FIG. 3 Spindle and Thrust Rod Components

8.5 SAE 10W Engine Oil.

8.6 00 Grade Steel Wool.

9. Preparation of Bearings

9.1 Carefully remove new bearings (cups and cones) from their packages and place in a suitable clean container. Wash with *n*-heptane to remove all rust preventative.

9.2 Repeat washing with *n*-heptane two additional times to be certain all rust preventative has been removed. Use a clean beaker each time.

9.3 Drain *n*-heptane from the bearings and set them on a clean, lint-free cloth or towel to air dry.

NOTE 3—Cleaning may be facilitated by the use of a sonic cleaner.

10. Procedure

10.1 Prior to each test, check the freedom of movement of the thrust loading shaft (Fig. 3) in the spindle. If binding is noted, remove and clean both shaft and spindle bore.

10.2 Install new cups in the cleaned hub in the location shown by Figs. 1 and 2.

10.3 Weigh an inboard and outboard bearing cone to the nearest 0.1 g. Using the grease packer shown in Figs. 5 and 6 and an extra set of cups, fill the cones with the test grease. Use care to avoid moving the rollers or bearing components while removing the cones from the cups and in all subsequent wiping and handling steps. Strike off excess grease flush with the front face of the cone (near small end of rollers) using a small spatula. Wipe all grease from cone bore, cone back face, exterior cage surfaces, and exposed roller surfaces with a clean, lint-free cloth or towel and reweigh. Adjust the grease weight in the inboard cone to 3.0 ± 0.1 g and in the outboard cone to

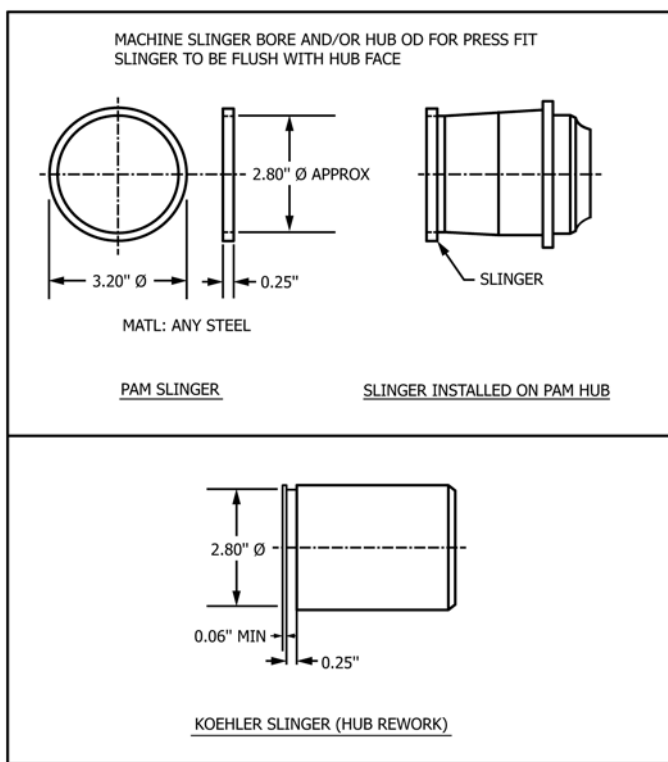

FIG. 4 Grease Sliders for Pam and Koehler Hubs

8.2 *n*-heptane—reagent grade minimum purity. (Warning—Flammable. Harmful if inhaled.)

8.3 Isopropyl Alcohol—reagent grade minimum purity. (Warning—Flammable.)

8.4 Mineral Spirits—reagent grade. (Warning—Combustible. Vapors may be harmful.)

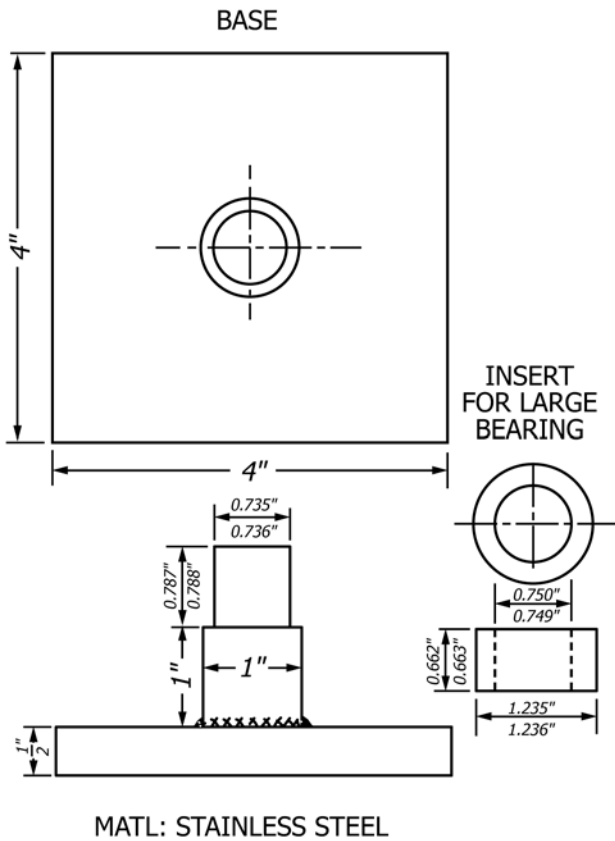

FIG. 5 Bearing Packer

2.0 ± 0.1 g by wiping or adding grease to the groove between the cage and the cone back face. Apply a thin film of grease on the cups.

10.4 Distribute 55.0 ± 0.2 g of grease in a uniform layer in the hub.

10.5 Weigh the leakage collector to the nearest 0.1 g.

10.6 Install the leakage collector, inboard cone, hub, and outboard cone on the spindle (Fig. 2). Lock the components in place with the end cap and screw. Install the spindle connector.

10.7 Referring to Fig. 3, adjust the thrust load as follows: Tighten the compression nut (G) until the spring (F) is seated against the back plate (E), *but not compressed*. Bring the lock nut (H) up to the compression nut (G). Without moving H, compress F by tightening G until the compression gage (J) will fit between H and G. Hold J in position and back off G until J is held firmly between H and G.

NOTE 4—Compression gage J has been machined such that insertion and adjustment of G causes spring F to compress and apply approximately 111 N (25 lbf) of axial loading on the wheel bearings. It is the understanding of Subcommittee G that the intent of the axial load is to ensure that the bearing is properly aligned on the spindle and remains so through the duration of the test.

Evaluation of a limited selection of these parts indicates the potential for significant variations in axial load when the instructions in 10.5 are followed. Since it was first published, this test method has not required calibration of the compression nut, spring, and gauge. So it seems that it is not critical to achieve an axial load of 111 N within an unspecified tolerance. Therefore there is no requirement to calibrate the test parts or to confirm the loading achieved.

10.8 Insert the thermocouple in the spindle thrust rod and position the junction at the center of the outboard bearing position. Close the cabinet and position the motor to operating location.

NOTE 5—Do not engage the drive at this point. Start the motor and adjust the speed to 1000 ± 50 rpm. At this point observe and record the unloaded motor current (N).

10.9 Turn off the motor, engage the drive coupling, and lock in position. Set the timer to begin 20 h cycle. Restart the motor and again adjust the speed to 1000 ± 50 rpm. Turn on the heaters and adjust the oven temperature to maintain the spindle temperature at 160 ± 1.5 °C (320 ± 2.7 °F). When the spindle temperature has stabilized at the test temperature, make no further adjustment of the oven temperature for the duration of the test.

10.10 A steady-state running torque will develop in the first 2 h of operation as indicated by a stabilized value on the meter. Record this value as steady-state current (T). Determine the motor cutoff value as follows:

$$C = 8(T - N) + N \quad (1)$$

where:

C = motor cut-off value, amps,

T = steady-state current, amps, and

N = unloaded motor current, amps.

Set the automatic torque cut-off of motor to value C.

10.11 Permit the apparatus to operate under the prescribed conditions of load, speed, and temperature for 20 ± 0.25 h. If the preset torque cut-off is exceeded, the test will be terminated automatically.

NOTE 6—The motor is protected by a 30-s time delay.

10.12 Open the cabinet and allow the tester to cool to approximately 55 °C using ambient air and no additional cooling aids (that is, fans) to facilitate disassembly.

10.13 Weigh the leakage collector to the nearest 0.1 g and report the weight as grease leakage. The grease collector will contain about 15 g before overflowing. This represents about 25 % of the total grease charge. If the collector overflows, report grease leakage as +25 %.

11. Parts Cleanup

11.1 With a spatula, remove as much grease as possible from the hub, grease collector, end cap, and spindle connector.

11.2 Place the parts in a suitable clean container (preferably stainless steel) and cover with Penmul L460 (see 8.1). Install a loosely fitting cover and heat gently (70 ± 10 °C) until the parts are clean (several hours). Avoid prolonged (overnight) heating as parts corrosion can occur.

11.3 Remove the parts from the solvent and wash with hot running water. Rinse immediately with isopropyl alcohol (see 8.3). Air dry. If the parts will not be used immediately, apply a thin film of SAE 10W engine oil.

11.4 Use a spatula to scrape grease off of the spindle. Remove remaining deposits from the spindle using 00 grade

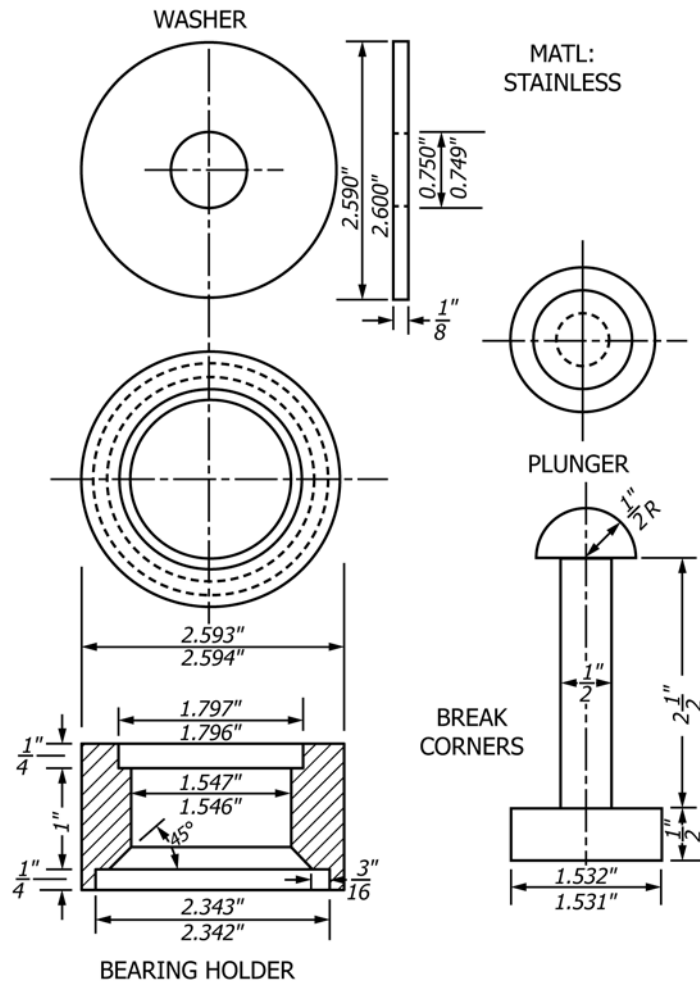

FIG. 6 Bearing Packer

steel wool and mineral spirits (see 8.4). If strongly adherent deposits resist this treatment, remove the spindle and clean in hot Penmul L460.

12. Report

12.1 Report the leakage to the nearest 0.1 g as determined in 10.13.

12.2 Report other observations such as grease movement in the hub, condition of the bearings, and so forth.

12.3 Report the presence on the bearing surface of any adherent deposit of varnish, gum, or lacquer-like material, which is evident after removal of the grease.

NOTE 7—With some wheel bearing greases, it will be found that grease thickeners are not completely washed from the bearings with ASTM *n*-heptane. A film of grease thickener may, therefore, remain on the bearings. This film can be readily distinguished from varnish, gum, or lacquer-like deposits resulting from deterioration of the lubricant.

13. Precision and Bias⁴

13.1 *Precision*—The precision of this test method was determined by statistical examination of interlaboratory results.

⁴ Supporting data (cooperative test programs to develop this procedure) have been filed at ASTM International Headquarters and may be obtained by requesting Research Report RR:D02-1176.

In 1988 a more precise bearing packing procedure was included in 10.3. The precision data shown was obtained earlier using a less detailed packing procedure:

13.1.1 *Repeatability*— The difference between two test results obtained by the same operator with the same apparatus under constant operating conditions on identical test material would, in the long run, in the normal and correct operation of the test method, exceed the following values in only one case in twenty.

$$\text{Repeatability} = (1.504) \sqrt{X} \quad (2)$$

where:

X = the average of the two test results.

13.1.2 *Reproducibility*— The difference between two single and independent results obtained by different operators working in different laboratories on identical test material would, in the long run, in the normal and correct operation of the test method, exceed the following values in only one case in twenty.

$$\text{Reproducibility} = (3.848) \sqrt{X} \quad (3)$$

where:

X = the average of the two test results.

13.2 *Bias*—The procedure in Test Method D4290 for measuring the leakage tendencies of automotive wheel bearing greases under accelerated conditions has no bias because the value of grease leakage can be defined only in terms of the test method.

NOTE 8—A round robin of eleven cooperators testing five greases has resulted in the precision statement shown above. The data are shown in

Table X1.1 of Appendix X1. In this round robin, determinations were made using testers by Pam and by Koehler. No distinction was made as both testers gave equivalent results.

14. Keywords

14.1 leakage automotive wheel bearing; lubricating grease; wheel bearing grease

APPENDIX

(Nonmandatory Information)

X1. ROUND ROBIN DATA

X1.1 The precision statement of eleven cooperators is presented in Table X1.1. Table X1.2 provides the metric equivalents for Fig. 1, Fig. 3, Fig. 5, and Fig. 6.

TABLE X1.1 Replicate Results—Mass Leakage, g: Wheel Bearing Leakage

Laboratory ^A		Sample Number				
		G-8018	G-8019	G-8020	G-823	G-824
1	X ₁ ^B	13.0	1.3	3.5	8.9	12.1
K	X ₂ ^C	7.7	0.6	7.0	11.2	7.7
1	X ₁	10.2	3.2			
P	X ₂	11.5	2.9			
2	X ₁	10.3	3.3	2.5	11.5	2.0
P	X ₂	5.2	2.4	3.8	11.5	3.0
3	X ₁	14.1	4.5	7.3	15.2	15.2
P	X ₂	12.4	5.4	8.6	15.9	11.4
4	X ₁	14.5	3.1	8.0	15.0	10.0
P	X ₂	15.5	3.0	9.3	13.0	9.0
5	X ₁	7.7	2.0	3.4	9.1	4.3
K	X ₂	10.8	2.1	4.9	7.4	4.6
6	X ₁	10.2	0.2	0.0		
P	X ₂	11.5	0.0	0.0		
7	X ₁	10.6	1.0	3.5	25.3	7.9
P	X ₂	9.8	0.6	3.3	27.5	5.4
8	X ₁	12.6	2.4	5.6	9.8	7.2
P	X ₂	14.8	1.2	4.8	11.7	5.1
9	X ₁	10.0	8.0	12.0	16.0	12.0
P	X ₂	13.0	6.5	8.1	15.0	16.0
10	X ₁	9.6	0.1	1.8	5.0	3.3
K	X ₂	8.8	0.0	1.1	6.2	2.8
11	X ₁	12.6	0.6	3.6	9.5	4.5
P	X ₂	11.3	1.8	3.2	9.1	6.6

^A Sum total laboratories = m = 11 + 1. Some laboratories have more than one tester. In this event each tester is considered another laboratory.

^B X₁ is first result.

^C X₂ is second result.

**TABLE X1.2 Metric Equivalents for
Fig. 1, Fig. 3, Fig. 5, and Fig. 6**

in.	mm
1/8	3.175
1/4	6.350
1/2	12.700
0.661	16.789
0.662	16.815
0.736	18.694
0.735	18.669
0.749	19.025
0.75	19.050
0.787	19.990
1.00	25.400
1.235	31.369
1.236	31.394
1.531	38.887
1.532	38.913
1.546	39.268
1.547	39.294
1.796	45.618
1.797	45.644
2.342	59.487
2.343	59.512
2 1/2	63.500
2.590	65.786
2.6	66.040
2.594	65.888
4.0	101.600
6.0	152.400
6 1/8	155.570
8 3/4	222.250
12 1/2	317.500

SUMMARY OF CHANGES

Subcommittee D02.G0 has identified the location of selected changes to this standard since the last issue (D4290 – 07 (2012)) that may impact the use of this standard. (Approved April 1, 2015.)

(1) Revised subsection **4.1** and **Note 4**.

ASTM International takes no position respecting the validity of any patent rights asserted in connection with any item mentioned in this standard. Users of this standard are expressly advised that determination of the validity of any such patent rights, and the risk of infringement of such rights, are entirely their own responsibility.

This standard is subject to revision at any time by the responsible technical committee and must be reviewed every five years and if not revised, either reapproved or withdrawn. Your comments are invited either for revision of this standard or for additional standards and should be addressed to ASTM International Headquarters. Your comments will receive careful consideration at a meeting of the responsible technical committee, which you may attend. If you feel that your comments have not received a fair hearing you should make your views known to the ASTM Committee on Standards, at the address shown below.

This standard is copyrighted by ASTM International, 100 Barr Harbor Drive, PO Box C700, West Conshohocken, PA 19428-2959, United States. Individual reprints (single or multiple copies) of this standard may be obtained by contacting ASTM at the above address or at 610-832-9585 (phone), 610-832-9555 (fax), or service@astm.org (e-mail); or through the ASTM website (www.astm.org). Permission rights to photocopy the standard may also be secured from the Copyright Clearance Center, 222 Rosewood Drive, Danvers, MA 01923, Tel: (978) 646-2600; http://www.copyright.com/