



Standard Test Method of Measuring Humidity with Cooled-Surface Condensation (Dew-Point) Hygrometer¹

This standard is issued under the fixed designation D4230; the number immediately following the designation indicates the year of original adoption or, in the case of revision, the year of last revision. A number in parentheses indicates the year of last reapproval. A superscript epsilon (ϵ) indicates an editorial change since the last revision or reapproval.

1. Scope

1.1 This test method covers the determination of the thermodynamic dew- or frost-point temperature of ambient air by the condensation of water vapor on a cooled surface. For brevity this is referred to in this method as the condensation temperature.

1.2 This test method is applicable for the range of condensation temperatures from 60°C to – 70°C.

1.3 This test method includes a general description of the instrumentation and operational procedures, including site selection, to be used for obtaining the measurements and a description of the procedures to be used for calculating the results.

1.4 This test method is applicable for the continuous measurement of ambient humidity in the natural atmosphere on a stationary platform.

1.5 *This standard does not purport to address all of the safety concerns, if any, associated with its use. It is the responsibility of the user of this standard to establish appropriate safety and health practices and determine the applicability of regulatory limitations prior to use.* For specific precautionary statements, see Section 8.

2. Referenced Documents

2.1 *ASTM Standards:*²

[D1356 Terminology Relating to Sampling and Analysis of Atmospheres](#)

[D3631 Test Methods for Measuring Surface Atmospheric Pressure](#)

3. Terminology

3.1 *Definitions:*

¹ This test method is under the jurisdiction of ASTM Committee D22 on Air Quality and is the direct responsibility of Subcommittee D22.11 on Meteorology.

Current edition approved April 1, 2012. Published July 2012. Originally approved in 1983. Last previous edition approved in 2007 as D4230 - 02(2007). DOI: 10.1520/D4230-02R12.

² For referenced ASTM standards, visit the ASTM website, www.astm.org, or contact ASTM Customer Service at service@astm.org. For *Annual Book of ASTM Standards* volume information, refer to the standard's Document Summary page on the ASTM website.

3.1.1 For definitions of other terms in this method, refer to Terminology [D1356](#).

3.2 *Definitions of Terms Specific to This Standard:*

3.2.1 *nonhygroscopic material*—material that neither absorbs nor retains water vapor.

3.2.2 *mirror (front surface)*—a polished surface, usually a metallic surface, on which condensates are deposited.

3.3 *Symbols:*

e	= vapor pressure of water vapor in moist air.
e_i	= saturation pressure of water vapor in equilibrium with the plane surface of ice.
e_w	= saturation pressure of water vapor in equilibrium with the plane surface of water.
P	= ambient pressure.
r	= mixing ratio.
T	= ambient air temperature.
T_d	= thermodynamic dew- or frost-point temperature.
RH_i	= relative humidity with respect to ice.
RH_w	= relative humidity with respect to water.

4. Summary of Test Method

4.1 The ambient humidity is measured with a dew- and frost-point hygrometer.

4.2 The mirror or some other surface on which the condensate is deposited is provided with the means for cooling and heating, detection of condensate, and the measurement of the temperature of the mirror surface.

4.3 Calculations of saturation vapor pressure over water and ice as functions of temperature are provided.

5. Significance and Use

5.1 Humidity information is important for the understanding of atmospheric phenomena and industrial processes. Measurements of the dew-point and calculations of related vapor pressures are important to quantify the humidity information.

6. Interferences

6.1 This method is not applicable if other constituents in the atmosphere condense before water vapor.

7. Apparatus

7.1 *Dew-point hygrometers*, specifically designed for meteorological observations are available commercially. A schematic arrangement of a typical optical dew-point hygrometer is shown in Fig. 1.

7.1.1 The sample air flows through a small chamber.

7.1.2 Within the chamber is a mirror or surface on which the condensate can be deposited.

7.1.3 A beam of light from an incandescent lamp, light emitting diode or other suitable light source shines on the mirror.

7.1.4 Dew or frost is detected with an electro-optic device.

7.1.5 The mirror is cooled by a Peltier thermoelectric element. Peltier cooling is a convenient method for unattended and automatic instruments.

7.1.6 Preferred devices of sensing mirror temperature are resistance thermometers, thermistors, and thermocouples.

7.1.6.1 The temperature sensors shall be attached to or embedded in the mirror to measure the temperature of the surface of the mirror.

7.1.7 Suitable control circuitry shall be provided to maintain a constant quantity of condensate on the mirror.

7.1.8 Suitable provisions shall be provided to compensate for the contamination of the surface of the mirror.

7.2 Auxiliary Equipment:

7.2.1 Provision shall be provided for assuring air flow past the dewpoint mirror without changing the pressure in the mirror chamber more than 0.5 % from the ambient pressure surrounding the sensor. An air flow of approximately 1.1 litres per minute is recommended for typical chambers.

7.2.2 Readout instrumentation is available with the dew-point hygrometer.

8. Precautions

8.1 Safety Precautions:

8.1.1 The hygrometer shall be packaged in a suitable enclosure for application in industrial or outdoor environment.

8.1.2 Electrical connectors and cables shall be suitable for the industrial or outdoor environment.

8.1.3 Appropriate voltage surge protection circuitry must be incorporated.

8.2 Technical Precautions:

8.2.1 The accuracy of a cooled-surface condensation hygrometer is degraded by the presence of water-soluble materials. A mirror-cleaning schedule, consistent with the contamination rate, is necessary to maintain the initial calibration accuracy. The user must determine the required maintenance schedule for the specific site, by comparison of calibrations made before and after cleaning.

8.2.2 Caution in performing this method should be taken if the indicated mirror temperature is between 0°C and – 30°C. Below freezing, the initial formation of the condensate on the surface of a mirror may be either dew or frost. In the case of nonfiltered atmospheric air, the supercooled water usually does not persist long on a mirror surface and quickly changes to frost. The only positive method for determining the state of the condensate is by visual observation of the mirror surface.

8.2.2.1 The following illustrates the magnitude of the error involved when dew or frost is not differentiated: The saturation vapor pressure of supercooled water at – 30°C corresponds to saturation vapor pressure of ice at – 27.2°C; dew point of – 20°C corresponds to frost point of – 18.0°C; – 10°C dew point corresponds to frost point of – 8.9°C. (The frost point temperature is approximately 90 % of the dew-point temperature in degrees Celsius.)

8.2.3 A positive method for identifying the state of the condensate is to visually observe the condensate on the mirror with the aid of a microscope or other optical magnifier.

8.2.4 A finite length of time is required for the condensate to deposit on the mirror and for the hygrometer to reach equilibrium with the ambient humidity. The response of the hygrometer depends on the humidity of the ambient air, and on such factors as the ventilation rate of the ambient air past the mirror, the sensitivity of the condensate detector, and the maximum cooling rate of the hygrometer. The worst case occurs during the initial dew-point reading after clearing the mirror of all condensates. The time it takes the hygrometer to reach equilibrium after clearing the mirror will vary from instrument to instrument. As an illustration of the magnitude of this time, the following are approximate times required by a hygrometer to reach equilibrium after clearing the mirror.

8.2.4.1 For dew points warmer than 0°C: 5 min after clearing.

8.2.4.2 For dew points 0°C to – 20°C: 5 to 20 min after clearing.

8.2.4.3 For dew points – 20°C to – 40°C: 20 min to 1 h after clearing.

8.2.4.4 For dew points – 40°C to – 60°C: 1 h to 2 h after clearing.

8.2.4.5 For dew points – 60°C to – 70°C: 2 h to 6 h after clearing.

8.2.5 The pressure differential between the mirror chamber and the ambient shall not be greater than 0.5 % of the ambient pressure. For example, the difference shall not exceed 5 hPa at an ambient pressure of 1000 hPa.

8.2.6 The thermometer must measure the temperature of the mirror surface and not be influenced by the ambient air temperature.

8.2.7 All materials, which come into contact with the sample air before it reaches the dew-point mirror, shall be

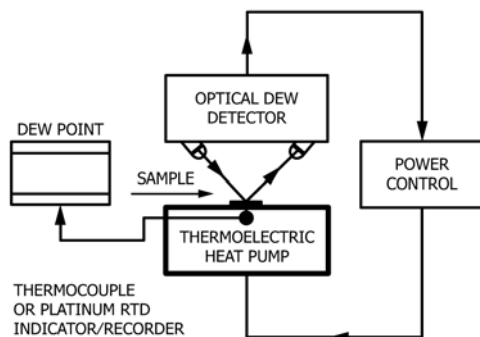

FIG. 1 Schematic of a Thermolectric Cooled Condensation Hygrometer

nonhygroscopic. Metal, glass, polytetrafluoroethylene, or stabilized polypropylene are examples of suitable materials. Polyvinyl chloride tubing must be avoided.

9. Sampling

9.1 Automatic dew-point hygrometers provide an output which may be recorded continuously. Modern data loggers sample temperature-sensor output periodically, convert the analog sensor signal to a digital form, and store the data. The proper sampling interval depends on the data application (see 13.2).

9.2 Locate a blower or pump, which can be used to move the air sample through the mirror chamber, downstream of the dew-point mirror. The airflow rate also depends on the data application and sampling environment.

9.3 Select the site or location so that the measurement data represents the water vapor content of the ambient atmosphere or industrial environment being sampled. Local water vapor sources, including ponds, wet roads, and structures can influence the ambient humidity. Avoid sources of airborne contaminants that can influence to condensation process on the mirror.

9.4 The successful application of this method requires that all the materials which come in contact with the sample air upstream of the dew-point mirror be nonhygroscopic.

9.5 The materials which come in contact with the sample air upstream of the dew-point mirror might be wetted by rain, dew, or frost; for example, dew forming on a surface in the early morning. Design the sampling system to minimize these deleterious effects.

10. Calibration

10.1 Provide the calibration data for the thermometer, used for measuring the condensation temperature with the hygrometer. Consult the manufacturer's operating manual for calibrating the thermometer readout instrumentation.

10.2 The cooled-surface condensation (dew-point) method is considered to be an absolute or fundamental method for measuring humidity. This method requires an accurate measurement of the temperature of the surface of the dew-point mirror. It is not uncommon for the dew-point temperature to be more than 35 °C colder than the ambient air temperature. To measure this temperature accurately, without being influenced by the warmer ambient and the colder heat-sink temperature, requires careful placement of the dew-point thermometer.

10.3 Therefore, in addition to the temperature calibration of the thermometer, (see 10.1), a humidity calibration must also be performed to verify the proper operation of the hygrometer (see Annex A1). The following are additional examples of factors that can affect the accuracy of the measurement: extraneous thermally-induced voltage (emf), heat leakage through the thermometer leads, self-heating of the thermometer, poor thermal contact, temperature gradient across the mirror, etc.

11. Procedure

11.1 *Selection of Sampling Site*—Select sampling site as indicated in 9.3 and also in 1.3.2 of the World Meteorological Organization, *Guide to Meteorological Instrument and Observing Practices (1)*.³

11.2 Consult the manufacturer's operating manual for start-up procedures.

11.3 Perform necessary calibration as indicated in Section 10. The dew-point thermometer will not undergo large shifts (0.05°C) in calibration unless it is subjected to physical shock. If the thermometer read-out instrumentation is subjected to varying ambient temperatures, the read-out instrumentation checks must be over the expected range of ambient temperatures. The frequency with which these checks are required will be determined by the stability of the readout instrumentation.

11.4 Check and verify that all necessary variables are measured and recorded to compute the humidity in the desired unit(s) see also 12.

NOTE 1—In general, it is recommended that ambient temperature and pressure (the pressure in the mirror chamber should not differ from the ambient pressure by more than 0.5 %) and the dew-point temperature be measured and recorded. The ambient pressure is to be measured according to Test Methods D3631. This will enable other users of the data to calculate in the different units of humidity.

12. Calculations

12.1 In the meteorological range of pressure and temperature, the saturation vapor pressure of the pure water phase and of the moist air will be assumed to be equal. This assumption will introduce an error of approximately 0.5 % of reading or less.

12.2 Calculate the ambient relative humidity with respect to water using the following approximation.

$$(RH_w)_T = \frac{e(T_d)}{e_w(T)} 100 \% \quad (1)$$

where:

$(RH_w)_T$ = relative humidity with respect to water, %, at temperature T (°C),

$e(T_d)$ = saturation vapor pressure, Pa, at condensation temperature T_d , °C, where T_d is the average value during the sampling period, see Note 2, and

$e_w(T)$ = saturation vapor pressure, Pa, over water at ambient temperature T, °C, where T is the average value during the sampling period.

NOTE 2—If the condensate on the mirror is water (dew), use the saturation vapor pressure over water corresponding to the condensation temperature T_d . If the condensate is ice (frost), use the saturation vapor pressure over ice corresponding to the condensation temperature T_d . Equations for saturation vapor pressure are provided in 12.5.

12.3 Calculate the relative humidity with respect to ice as follows:

$$(RH_i)_T = \frac{e(T_d)}{e_i(T)} 100 \% \quad (2)$$

³ The boldface numbers in parentheses refer to the references at the end of this method.

where:

$(RH_i)_T$ = relative humidity with respect to ice, %, at temperature T ($^{\circ}\text{C}$),

$e_i(T)$ = saturation vapor pressure, Pa, over ice at ambient temperature T , $^{\circ}\text{C}$, where T is the average value during the sampling period, and

$e(T_d)$ = see 12.2.

12.4 Saturation vapor pressure calculations are provided in this section. The equations provided in 12.4.1 – 12.4.4 are recent formulations (2) of the Magnus form of exponential expressions for saturation vapor pressure. Using similar constants from other reliable resources can yield reasonably accurate results as well. Using the appropriate equation depending if the condensate is water or ice will improve the accuracy of the calculation. The calculations for moist air rather than the pure water vapor equations could improve the accuracy by 0.6 % for water and 0.88 % for ice (2).

12.4.1 Saturation vapor pressure of pure water vapor over a plane surface of water, $e_w(T)$ in hPa at a temperature $T(^{\circ}\text{C})$ can be calculated by:

$$e_w(T) = 6.1094 e^{17.625 T/(243.04+T)}$$

12.4.2 Saturation vapor pressure of moist air over a plane surface of water, $e_{wa}(T)$ in hPa at a temperature $T(^{\circ}\text{C})$, pressure P in hPa, and saturation vapor pressure of pure water vapor over a plane surface of water, $e_w(T)$ in hPa, can be calculated by:

$$e_{wa}(T) = e_w(T) 1.00071 e^{0.0000045 P}$$

12.4.3 Saturation vapor pressure of pure water vapor over a ice, $e_i(T)$ in hPa at a temperature $T(^{\circ}\text{C})$ can be calculated by:

$$e_i(T) = 6.1121 e^{22.587 T/(273.86+T)}$$

12.4.4 Saturation vapor pressure of moist air over a ice, $e_{ia}(T)$ in hPa at a temperature $T(^{\circ}\text{C})$, pressure P in hPa, and saturation vapor pressure of pure water vapor over ice, $e_i(T)$ in hPa can be calculated by:

$$e_{ia}(T) = e_i(T) 0.99882 e^{0.000008 P}$$

12.4.5 Alternatively, polynomial expressions have been developed that yield calculation results that are more completely accurate over a broader temperature range than the exponential approximations shown above. Examples of the polynomial expressions follow which are consistent with the NIST humidity standards (3).

12.4.5.1 The saturation vapor pressure (e_s) for water in the temperature range between 0°C and 100°C is:

$$e_s = 2.70102980826 \times 10^{-6} T^5 + 2.92123923916 \times 10^{-4} T^4 + 2.53760036868 \times 10^{-2} T^3 + 1.48376504190 T^2 + 4.37196700302 \times 10^1 T + 6.13141885322 \times 10^2$$

12.4.5.2 The saturation vapor pressure for ice (e_s in Pa) in the temperature range between 173.15 K and 273.15 K is:

$$\ln \frac{e_s}{611.657} = a_1(1 - \theta^{-1.5}) + a_2(1 - \theta^{-1.25})$$

where:

$$\theta = (T + 273.15) / 273.16$$

$$a_1 = -13.9281690$$

$$a_2 = 34.7078238$$

12.5 Calculate the mixing ratio as follows:

$$r = 0.6220 e(T_d) / [P - e(T_d)] \quad (3)$$

where:

r = mixing ratio and

$e(T_d)$ = see 12.2.

12.6 Calculate parts per million by mass as follows:

$$\text{ppm}_m = r \times 10^6 \quad (4)$$

12.7 Calculate parts per million by volume as follows:

$$\text{ppm}_v = e(T_d) / [P - e(T_d)] \times 10^6 \quad (5)$$

13. Precision and Bias

13.1 The estimated precision for this method is valid only for constant ambient humidity and the precision varies with the condensation temperature as shown in Fig. 2. The precision is based on single-laboratory and multioperator-device test.

13.2 The estimated bias of the dew-point hygrometer, as shown in Fig. 2, is valid only for constant ambient humidity. This is true especially for low-condensation temperatures. The bias varies from $\pm 0.4^{\circ}\text{C}$ for condensation temperatures above freezing to $\pm 2.0^{\circ}\text{C}$ at condensation temperature -70°C . All uncertainties are at the 95 % confidence level.

13.3 If the standard deviation is equal to or less than the values listed in 13.3.1, the ambient humidity is assumed to be sufficiently constant so that the bias curve given in Fig. 2 is valid.

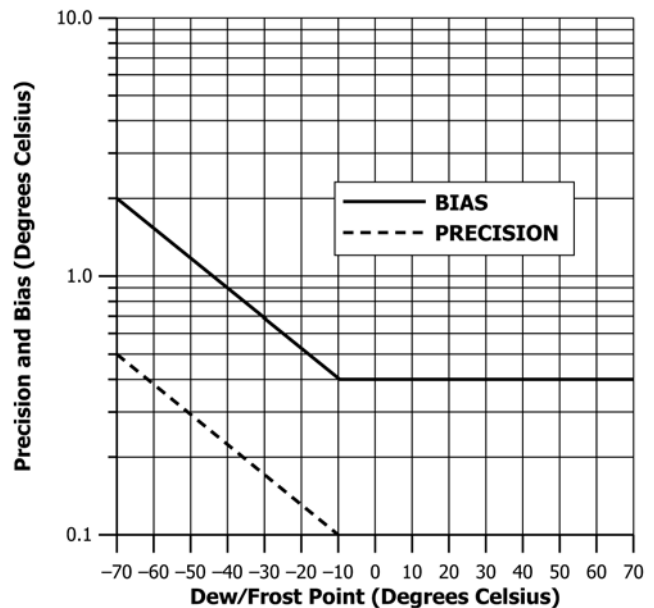

FIG. 2 Precision and Bias Versus Dew/Frost Point

13.3.1 The following criteria shall be used to determine whether the ambient humidity is constant:

Condensation Temperature (°C)	Duration of Sampling Time (min)	Number of Readings Taken Over Equally Spaced Time Intervals	Calculated Standard Deviation (°C)
-70	120	10 to 25	± 0.5
-60	90	10 to 25	± 0.4
-50	60	10 to 25	± 0.3
-40	30	10 to 25	± 0.2
-25	20	10 to 25	± 0.15
-10	15	10 to 25	± 0.1
60	15	10 to 25	± 0.1

13.4 The following is an example on use of the table in 13.3.1:

13.4.1 If the indicated condensation temperature is -50°C , take 10 to 25 readings taken at equally spaced time interval for a period of approximately 60 min, compute the average value (in this case -50°C) and the standard deviation. If this calculated standard deviation is equal to or less than $\pm 0.3^{\circ}\text{C}$, the ambient humidity is assumed to be constant and the bias of the reading at -50°C is $\pm 1.2^{\circ}\text{C}$ (See Fig. 2). See also 8.2.2.

14. Keywords

14.1 dew-point; humidity; hygrometer; saturation; temperature; dew-point; vapor pressure

ANNEXES

(Mandatory Information)

A1. LABORATORY CALIBRATION OF DEW-POINT HYGROMETER

A1.1 An accurate method for the calibration of the hygrometer is to test the instrument with a humidity generator that produces air of known humidity (4).

A1.2 An alternative method is by direct comparison with a secondary or working standard hygrometer when both instruments are subjected to the same, preferably constant, humidity.

NOTE A1.1—Secondary standard hygrometers are characterized by long term repeatability and predictable behavior when verified to be performing properly. Working standard hygrometers are characterized by satisfactory (which meet the users requirements) precision and stability when calibrated against a humidity generator or intercompared with a secondary standard.

A2. FIELD CALIBRATION OF DEW-POINT HYGROMETER

A2.1 Install a secondary or working standard hygrometer adjacent to the working hygrometer and run an intercomparison test. It is very important that the standard and the working hygrometers are sampling the same air mass. The exhaust air from both hygrometers must not be mixed with the intake air sample.

A2.2 If there is a fixed bias between the readings of the two hygrometers, interchange the positions of the two instruments to determine if the bias is due to sampling problems.

A2.3 The intercomparison test should continue until constant humidity indications, as defined in 13.2, are seen on both instruments. If the sample condensation temperature is steady, the duration of the test will be shorter than when there are large fluctuations in humidity.

A2.4 The tests should be performed during periods when the relative humidity is low and also during periods when the relative humidity is high. (A one-point verification check is sufficient if the working hygrometer had been calibrated prior to the installation in the field.)

REFERENCES

- (1) *Guide to Meteorological Instruments and Observing Practices*, World Meteorological Organization, WMO No. 8, TP3, Fourth Edition, 1971, Secretariat of WMO, Geneva, Switzerland.
- (2) Alduchov, Oleg A., and Eskridge, Robert A., "Improved Magnus Form Approximation of Saturation Vapor Pressure," *Journal of Applied Meteorology*, 35, April 1996, pp. 601-609.
- (3) Huang, P.H. *New equations for water vapor pressure in the temperature range -100°C to 100°C for use with the 1997 NIST/ASME steam tables*, Proceedings of the Third International Symposium on Humidity and Moisture, p. 68-76, 1998.
- (4) Hasegawa, S., and Little, J. W., "The NBS Two-Pressure Humidity Generator, Mark 2" *Journal of Research National Bureau of Standards (U.S.)*, 81A, No. 1, Jan. to Feb. 1977, pp. 81-88.

ASTM International takes no position respecting the validity of any patent rights asserted in connection with any item mentioned in this standard. Users of this standard are expressly advised that determination of the validity of any such patent rights, and the risk of infringement of such rights, are entirely their own responsibility.

This standard is subject to revision at any time by the responsible technical committee and must be reviewed every five years and if not revised, either reapproved or withdrawn. Your comments are invited either for revision of this standard or for additional standards and should be addressed to ASTM International Headquarters. Your comments will receive careful consideration at a meeting of the responsible technical committee, which you may attend. If you feel that your comments have not received a fair hearing you should make your views known to the ASTM Committee on Standards, at the address shown below.

This standard is copyrighted by ASTM International, 100 Barr Harbor Drive, PO Box C700, West Conshohocken, PA 19428-2959, United States. Individual reprints (single or multiple copies) of this standard may be obtained by contacting ASTM at the above address or at 610-832-9585 (phone), 610-832-9555 (fax), or service@astm.org (e-mail); or through the ASTM website (www.astm.org). Permission rights to photocopy the standard may also be secured from the Copyright Clearance Center, 222 Rosewood Drive, Danvers, MA 01923, Tel: (978) 646-2600; <http://www.copyright.com/>