



# Standard Test Method for Sustained Burning of Liquid Mixtures Using the Small Scale Open-Cup Apparatus<sup>1</sup>

This standard is issued under the fixed designation D4206; the number immediately following the designation indicates the year of original adoption or, in the case of revision, the year of last revision. A number in parentheses indicates the year of last reapproval. A superscript epsilon ( $\epsilon$ ) indicates an editorial change since the last revision or reapproval.

## INTRODUCTION

This test method may be used in conjunction with a flash point determination. If the flash point of a mixture of flammable and nonflammable liquids or liquids of widely different flash points is below the upper limit of a flammability classification (for example, 100°F specified by the U.S. Department of Transportation), this test may be conducted to determine the sustained burning characteristics of the mixture.

This test method is a modification of the test for combustibility now incorporated as Schedule 2 of the “Highly Flammable Liquids and Liquified Petroleum Gases Regulation, 1972” of the United Kingdom under The Factories Act, 1961, which is also issued as British Standard BS-3900, Part A-11, Small Scale Test for Combustibility. This sustained burning test was studied and proposed by the ASTM Coordinating Committee for Flash Point and Related Properties. The major purpose of this test is similar to that of the British test—to provide a method for determining the sustained burning characteristics by directly observing this property rather than by deducing them from the flash point.

## 1. Scope

1.1 This test method<sup>2</sup> describes a procedure for determining the sustained burning characteristics of mixtures of flammable and nonflammable liquids and to mixtures containing liquids with widely different flash points.

1.2 The values stated in inch-pound units are to be regarded as standard. The values given in parentheses are mathematical conversions to SI units that are provided for information only and are not considered standard.

1.3 *This standard should be used to measure and describe the response of materials, products, or assemblies to heat and flame under controlled conditions and should not be used to describe or appraise the fire-hazard or fire-risk of materials, products, or assemblies under actual fire conditions. However, results of the test may be used as elements of a fire-hazard assessment or a fire-risk assessment which takes into account all of the factors which are pertinent to an assessment of the fire hazard or fire risk of a particular end use.*

<sup>1</sup> This test method is under the jurisdiction of ASTM Committee D01 on Paint and Related Coatings, Materials, and Applications and is the direct responsibility of Subcommittee D01.21 on Chemical Analysis of Paints and Paint Materials.

Current edition approved June 1, 2013. Published June 2013. Originally approved in 1982. Last previous edition approved in 2007 as D4206 – 96 (2007). DOI: 10.1520/D4206-96R13.

<sup>2</sup> McKelvie, A. N., “A Test for Ability to Support Combustion for Liquids Including Paints and Allied Products,” *Journal of Oil Co. Chemical Assoc.*, 1972, Vol 55, pp. 1086–1095.

1.4 *This standard does not purport to address all of the safety concerns, if any, associated with its use. It is the responsibility of the user of this standard to establish appropriate safety and health practices and determine the applicability of regulatory limitations prior to use.*

## 2. Referenced Documents

2.1 *British Standards:*<sup>3</sup>  
[BS-3900 Part A-11, Small Scale Test for Combustibility](#)

## 3. Summary of Test Method

3.1 A block of aluminum alloy, or other nonrusting metal of suitable heat conductivity, with a concave depression (called the well) is heated to the required temperature of 120°F (49°C). A standard source of flame, capable of being swung over the center of the well and at a given distance from it, is attached to the metal block.

3.2 Two millilitres of the product under test are transferred to the well. After the product has reached the stated temperature, the flame is passed over the well, held there for a specified time, and then removed. The time of sustained burning is then noted.

<sup>3</sup> Available from British Standards Institute (BSI), 389 Chiswick High Rd., London W4 4AL, U.K., <http://www.bsi-global.com> or American National Standards Institute (ANSI), 25 W. 43rd St., 4th Floor, New York, NY 10036, <http://www.ansi.org>.

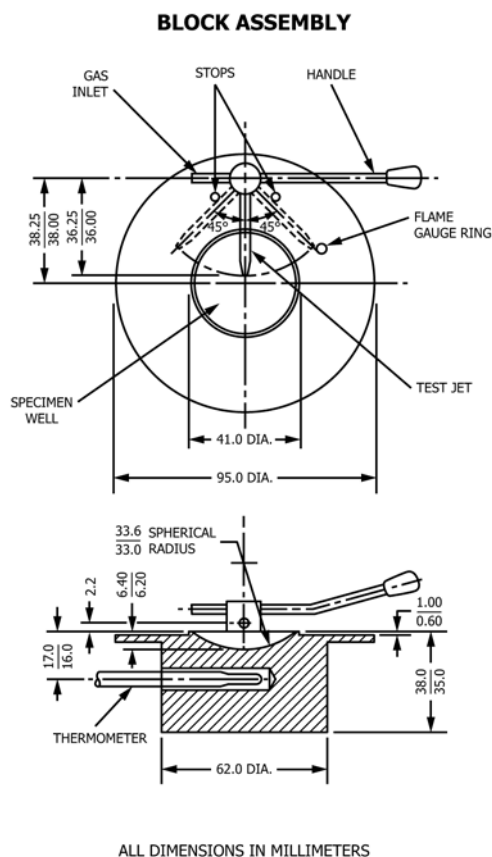

ALL DIMENSIONS IN MILLIMETERS  
**FIG. 1 Small Scale Open Cup Apparatus**

**4. Significance and Use**

4.1 Mixtures of flammable liquids and nonflammable liquids, such as an alcohol and water mixture, are classified by the U. S. Government by the definition of flammable liquid based on a closed-cup flash point method. Thus, mixtures may be classed as flammable even though they do not sustain burning. This test method determines the ability of a liquid mixture to sustain burning and, when used with a closed-cup flash point method, indicates the flammability characteristics of the mixture.

**5. Apparatus**

5.1 *Small Scale Open-Cup Apparatus*,<sup>4</sup> or an equivalent tester consisting of a 316 stainless steel block or other nonrusting block of suitable heat conductivity, fitted with a concave depression or well (Note 1). The metal block has a thermometer embedded in it. A small gas jet on a swivel is attached to the metal block. The exact dimensions of the metal block and its well, the gas jet and its positioning, and the embedded thermometer are shown in Fig. 1 and are specified in Annex A1.

NOTE 1—While the Small Scale Open-Cup Tester is generally made of an aluminum alloy, continued use of it for sustained burning tests may produce a carbon deposit in the well that may be difficult to remove

<sup>4</sup> Suitable apparatus is available from Erdco Engineering Corp., 721 Custer Ave., Evanston, IL 60204 or Stanhope-Seta Limited, Park Close, Englefield Egham, Surrey TW20 OXD, England.

without damaging the aluminum well. A stainless steel well may be cleaned with crocus cloth.

5.1.1 *Gage*—A metal strip, capable of checking the height of the gas jet above the top of the well lip ( $2.2 \pm 0.1$  mm).

5.1.2 *Hot Plate*, fitted with a temperature-controlling device or other means of heating the metal block.

5.1.3 *Stopwatch*, or other suitable timing device.<sup>4</sup>

5.2 *Thermometer*,<sup>4</sup> 32 to 230°F (–5 to 110°C), traceable to the National Institute of Standards and Technology.<sup>4</sup>

5.3 *Graduated Pipet or Hypodermic Syringe*,<sup>2</sup> capable of delivering  $2 \pm 0.1$  mL.

**6. Preparation of Sample**

6.1 Obtain a representative sample of the product under test, mixing it thoroughly, especially if it has a tendency to layer, and keep in an airtight container.

6.2 Because of the possibility of loss of volatile constituents, the sample should receive only the minimum treatment to assure uniformity. After removing the specimen, immediately close the sample container tightly to ensure that no volatile flammable components escape from the container. (Otherwise a new sample may be necessary if further testing is required.)

6.3 Do not open containers unnecessarily. Do not make transfers unless the sample temperature is at 100°F (37.8°C) or below, except for samples that are too viscous to be handled at that temperature. In these cases, transfer the samples at the lowest possible temperature at which the sample can be accurately measured into the cup.

6.4 Discard samples in leaky containers.

6.5 Do not store samples in plastic (polyethylene, polypropylene, etc.) bottles, since volatile material may diffuse through the walls of the bottles.

**7. Correction for Barometric Pressure**

7.1 When the barometric pressure differs from 760 mm Hg (101.3 kPa), determine the temperature at which the test should be conducted by the following equations:

$$F = 120^\circ F - 0.06 (760 - P) \tag{1}$$

$$C = 49^\circ C - 0.03 (760 - P)$$

$$F = 120^\circ F - 0.42 (101.3 - B)$$

$$C = 49^\circ C - 0.23 (101.3 - B)$$

where:

*F, C* = temperatures to obtain the equivalent of 120°F (49°C) at standard pressure,

*P* = barometric pressure, mm Hg, and

*B* = barometric pressure, kPa.

**8. Procedure**

8.1 Set up the apparatus (see 5.1) in a draft-free area. Place the metal block on the hot plate fitted with a temperature-controlling device, or heat the metal block by other suitable means so that the temperature is maintained within  $\pm 2^\circ F$

(±1°C) of the temperature 120°F (49°C) corrected, if necessary, for the difference in pressure from 760 mm Hg (101.3 kPa).

8.2 After the cup is within ±2°F (±1°C) of the correct test temperature, withdraw from the sample container a 2-mL specimen using the graduated syringe or pipet. Transfer the specimen to the well of the tester; immediately start the timing device.

8.3 Light the test flame with the jet in the “off” position away from the well. Adjust the size of the flame so that it is spherical and approximately 5/32 in. (4 mm) in diameter by matching it to the 5/32 in. diameter circle engraved on the surface of the tester.

8.4 After exactly 1 min (0 to +1 s) at which time the test portion will be deemed to have reached the test temperature as indicated by the thermometer embedded in the metal block, swing the test flame into a position exactly over the well. Hold it in this position for exactly 15 s, and then return it to the “off” position.

8.5 Observe and time the duration of the burning of the specimen following the return of the flame to the “off” position.

8.6 Repeat the test with a fresh specimen to determine the mean time of burning.

**9. Interpretation of Results**

9.1 A product is considered to sustain burning if the specimen (a) ignites when the flame is over the well and burning is sustained for more than 15 s after it is removed, or (b) flashes and burns when the test flame is in the “off” position prior to swinging it over the well.

**10. Report**

10.1 Report the following information:

10.1.1 Identification of the material under test,

10.1.2 Test temperature and barometric pressure in millimetres of mercury (kilopascals),

10.1.3 If the specimen burns less than 15 s, the actual time of burning, and

10.1.4 Statement of sustained burning characteristics.

**11. Precision**

11.1 The precision of this test method will be determined.

**12. Keywords**

12.1 small scale open-cup apparatus; sustained burning

**ANNEX**

**(Mandatory Information)**

**A1. DIMENSIONS OF TESTER**

**TABLE A1.1 Dimensions of Tester**

(a) Metal Block Details	Dimensions, mm
Diameter of block	61.5–62.5
Height of block	35.0–38.0
Diameter of flange	94.5–95.5
Flange thickness	3.0 approx.
Height of well “lip” above flange	0.6–1.0
Diameter of well “lip”	41.0 approx.
Spherical radius of well	33.0–33.5
Depth of well	6.2–6.4
Distance from top of block to thermometer hole	16.0–17.0
Thermometer hole diameter	7.0 approx.
(b) Test Gas Jet Details	Dimensions, mm
Outside diameter of jet	3.0–4.0
Jet end tapered to	1.7–2.3
Bore of jet	0.6–0.8
Length of jet (from center of axis to tip)	36.00–36.25
Distance of axis from center of wall	38.00–38.25
Flame gage ring diameter	4.0 ± 0.1
Height of jet above top of well “lip” <sup>A</sup>	2.2 ± 0.1
“Swing” of jet (from stop to stop)	90 ± 1°

<sup>A</sup> Adjust with suitable gage.

 **D4206 – 96 (2013)**

*ASTM International takes no position respecting the validity of any patent rights asserted in connection with any item mentioned in this standard. Users of this standard are expressly advised that determination of the validity of any such patent rights, and the risk of infringement of such rights, are entirely their own responsibility.*

*This standard is subject to revision at any time by the responsible technical committee and must be reviewed every five years and if not revised, either reapproved or withdrawn. Your comments are invited either for revision of this standard or for additional standards and should be addressed to ASTM International Headquarters. Your comments will receive careful consideration at a meeting of the responsible technical committee, which you may attend. If you feel that your comments have not received a fair hearing you should make your views known to the ASTM Committee on Standards, at the address shown below.*

*This standard is copyrighted by ASTM International, 100 Barr Harbor Drive, PO Box C700, West Conshohocken, PA 19428-2959, United States. Individual reprints (single or multiple copies) of this standard may be obtained by contacting ASTM at the above address or at 610-832-9585 (phone), 610-832-9555 (fax), or [service@astm.org](mailto:service@astm.org) (e-mail); or through the ASTM website ([www.astm.org](http://www.astm.org)). Permission rights to photocopy the standard may also be secured from the Copyright Clearance Center, 222 Rosewood Drive, Danvers, MA 01923, Tel: (978) 646-2600; <http://www.copyright.com/>*