



Designation: D4170 – 16

## Standard Test Method for Fretting Wear Protection by Lubricating Greases<sup>1</sup>

This standard is issued under the fixed designation D4170; the number immediately following the designation indicates the year of original adoption or, in the case of revision, the year of last revision. A number in parentheses indicates the year of last reapproval. A superscript epsilon ( $\epsilon$ ) indicates an editorial change since the last revision or reapproval.

### 1. Scope\*

1.1 This test method evaluates the fretting wear protection provided by lubricating greases.

1.2 The values stated in SI units are to be regarded as the standard.

1.2.1 *Exception*—Other units are provided for information only.

1.3 *This standard does not purport to address all of the safety concerns, if any, associated with its use. It is the responsibility of the user of this standard to establish appropriate safety and health practices and determine the applicability of regulatory limitations prior to use.* For specific warning statements, see 7.2 and 9.2.

### 2. Referenced Documents

#### 2.1 ASTM Standards:<sup>2</sup>

Test Methods for Rating Motor, Diesel, and Aviation Fuels; Motor Fuels (Section I), Reference Materials and Blending Accessories (Annex 2), Reference Fuels (A2.7.3.3), and Table 32 (Specification for *n*-Heptane Motor Fuel)

#### 2.2 Military Standard:<sup>3</sup>

MIL-S-22473D Sealing, Locking and Retaining Compounds, Single-Component

### 3. Terminology

#### 3.1 Definitions:

3.1.1 *fretting wear, n*—a form of attritive wear caused by vibratory or oscillatory motion of limited amplitude characterized by the removal of finely-divided particles from the rubbing surfaces.<sup>4</sup>

3.1.1.1 *Discussion*—Air can cause immediate local oxidation of the wear particles produced by fretting wear. In addition, environmental moisture or humidity can hydrate the

<sup>1</sup> This test method is under the jurisdiction of ASTM Committee D02 on Petroleum Products, Liquid Fuels, and Lubricants and is the direct responsibility of Subcommittee D02.G0.04 on Functional Tests - Tribology.

Current edition approved Dec. 1, 2016. Published February 2017. Originally approved in 1982. Last previous edition approved in 2010 as D4170 – 10. DOI: 10.1520/D4170-16.

<sup>2</sup> See 1998 *Annual Book of ASTM Standards*, Vol 05.04.

<sup>3</sup> Available from Standardization Documents Order Desk, DODSSP, Bldg. 4, Section D, 700 Robbins Ave., Philadelphia, PA 19111-5098.

<sup>4</sup> *NLGI Lubricating Grease Guide*, 3rd edition.

oxidation product. In the case of ferrous metals, the oxidized wear debris is abrasive iron oxide ( $\text{Fe}_2\text{O}_3$ ) having the appearance of rust, which gives rise to the nearly synonymous terms, fretting corrosion and friction oxidation. A related, but somewhat different phenomenon often accompanies fretting wear. False brinelling is localized fretting wear that occurs when the rolling elements of a bearing vibrate or oscillate with small amplitude while pressed against the bearing race. The mechanism proceeds in stages: (1) asperities weld, are torn apart, and form wear debris that is subsequently oxidized; (2) due to the small-amplitude motion, the oxidized detritus cannot readily escape, and being abrasive, the oxidized wear debris accelerates the wear. As a result, wear depressions are formed in the bearing race. These depressions appear similar to the Brinell depressions obtained with static overloading. Although false brinelling can occur in this test, it is not characterized as such, and instead, it is included in the determination of fretting wear.

### 4. Summary of Test Method

4.1 The tester is operated with two ball thrust bearings, lubricated with the test grease, oscillated through an arc of 0.21 rad ( $12^\circ$ ), at a frequency of 30.0 Hz (1800 cpm), under a load of 2450 N (550 lbf), for 22 h at room temperature (**Note 1**). Fretting wear is determined by measuring the mass loss of the bearing races.

**NOTE 1**—Arc, frequency, and load are factory-set operating conditions and should not be altered. The load spring constant may change over an extended time period. Spring calibration should be checked periodically and, if necessary, a suitable shim should be fabricated to obtain the required load ( $\pm 3\%$ ) at the assembled length of the spring.

### 5. Significance and Use

5.1 This test method is used to evaluate the property of lubricating greases to protect oscillating bearings from fretting wear. This method, used for specification purposes, differentiates among greases allowing low, medium, and high amounts of fretting wear under the prescribed test conditions. The test has been used to predict the fretting performance of greases in wheel bearings of passenger cars shipped long distances.<sup>5</sup> Test results do not necessarily correlate with results from other

<sup>5</sup> Verdura, T. M., "Development of a Standard Test to Evaluate Fretting Protection Quality of Lubricating Grease," *NLGI Spokesman*, Vol XLVII, No. 5, August 1983, pp. 157–67.

\*A Summary of Changes section appears at the end of this standard

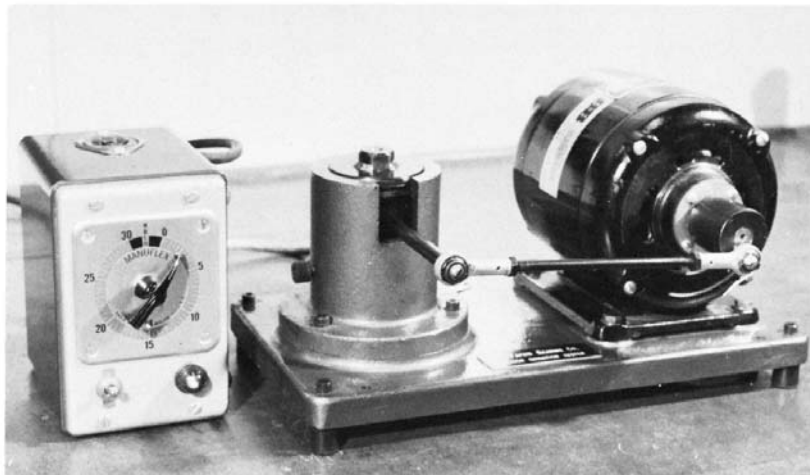

FIG. 1 Fafnir Friction Oxidation Tester and Time Switch

types of service. It is the responsibility of the user to determine whether test results correlate with other types of service.

## 6. Apparatus

6.1 *Falex Fretting Wear Tester, Model F-1581*,<sup>6,7</sup> as purchased and illustrated in Figs. 1 and 2.

6.2 *Spring Guide*, conforming to description in Fig. 3, if not supplied with tester.

6.3 *Test Bearings*,<sup>8,7</sup> of the ball thrust type having an inside diameter of 16.00 mm  $\pm$  0.025 mm (0.630 in.  $\pm$  0.001 in.), an outside diameter of 35.69 mm  $\pm$  0.025 mm (1.405 in.  $\pm$  0.001 in.), and assembled height of 15.75 mm  $\pm$  0.25 mm (0.620 in.  $\pm$  0.010 in.) and equipped with nine 7.142 mm (0.281 in.) diameter balls in a pressed steel retainer; all surfaces (except retainer) to be ground. Different surface finishes are provided on commercial bearings. Bearings with ground surfaces are lustrous; tumbled bearings appear slightly dulled or grayish. Bearings with ground races, as specified in 6.3, are required to obtain correct results. Tumbled bearings with reground races are satisfactory. Magnification should be used to inspect the races to verify that they have been ground. Part-number bearings<sup>8,7</sup> are provided with ground races. A drawing of the test bearing, giving complete, detailed dimensions and specifications is available in RR:D02-1159.<sup>9</sup>

6.4 *Vibration Mount*,<sup>10,7</sup> upon which the tester is placed.

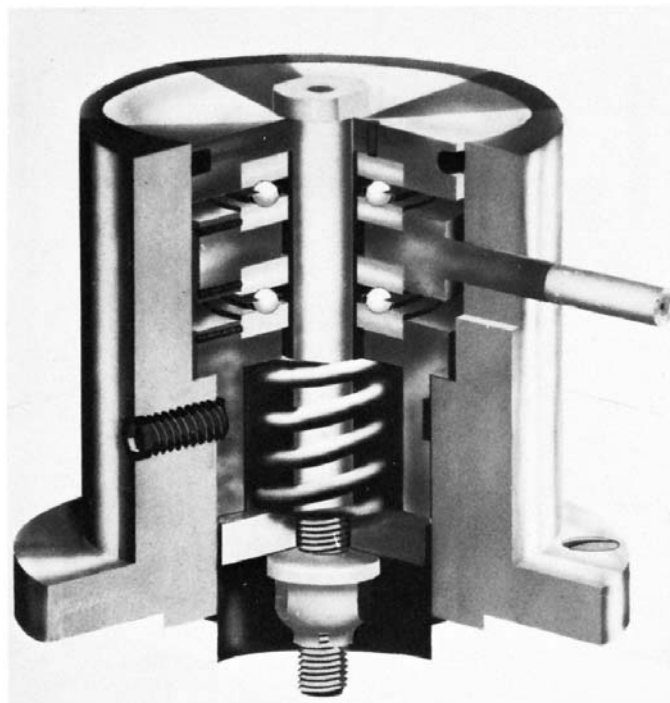

FIG. 2 Chuck and Housing Assembly

6.5 *Time Switch*, (optional) shown in Fig. 1 and described in detail in Fig. 4, or a commercial equivalent.

6.6 *Ultrasonic Cleaner*.<sup>11,7</sup>

6.7 *Analytical Balance* having a capacity of about 100 g and with a minimum sensitivity of 0.1 mg.

## 7. Reagents and Materials

7.1 *Purity of Reagents*—Reagent grade chemicals shall be used in all tests. Unless otherwise indicated, it is intended that

<sup>6</sup> Falex Fretting Wear Tester, formerly known as the Fafnir Friction Oxidation Tester, is available from Falex Corp., 1020 Airpark Dr., Sugar Grove, IL 60554.

<sup>7</sup> The sole source of supply of the apparatus known to the committee at this time is listed. If you are aware of alternative suppliers, please provide this information to ASTM Headquarters. Your comments will receive careful consideration at a meeting of the responsible technical committee,<sup>1</sup> which you may attend.

<sup>8</sup> Andrews (Part No. 06X65) have been found to be satisfactory. Prepared bearings (part number F-1581-50 (formerly FL-1081)), that is, with set screw flat (see 8.1), are available from Falex Corp., 1020 Airpark Dr., Sugar Grove, IL 60554.

<sup>9</sup> Supporting data (the results of the cooperative test program, from which these values have been derived) have been filed at ASTM International Headquarters and may be obtained by requesting Research Report RR:D02-1159.

<sup>10</sup> Isomode Vibration control Pad No. 3451801 has been found satisfactory and is available from rubber products suppliers.

<sup>11</sup> A Branson 2200 cleaner (Branson Ultrasonics Co., Danbury, CT 06813) having a capacity of about 3 L (¾ gal) operating at a frequency of about 55 kHz, with a power input of about 125 W, has been found satisfactory.

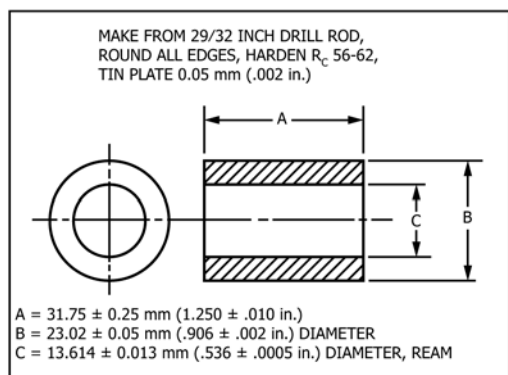

FIG. 3 Spring Guide

all reagents shall conform to the specifications of the Committee on Analytical Reagents of the American Chemical Society where such specifications are available.<sup>12</sup> Other grades may be used, provided it is first ascertained that the reagent is of sufficiently high purity to permit its use without lessening the accuracy of the determination.

7.2 *n*-heptane, reagent grade or ASTM Motor Fuel Grade 3. (Warning—Flammable. Health hazard.)

NOTE 2—This test method was originally developed using chloroform, which was subsequently replaced by 1,1,1-trichloroethane because of its lower toxicity. Since then, 1,1,1-trichloroethane was declared an Ozone Depleting Substance by the U.S. Environmental Protection Agency (EPA). Federal regulations ban the production of this material after December 31, 1995, but existing stocks may continue to be used. Currently there are no EPA restrictions on the use of chloroform, but the user should be aware of its health hazards if it is used as a functionally equivalent solvent. No other solvent intended as a substitute for 1,1,1-trichloroethane in this test method has been cooperatively evaluated. However, it is the experience of the Grease Subcommittee that elimination of the cleaning step using 1,1,1-trichloroethane does not affect the reported results from this test.

## 8. Bearing Preparation

8.1 Grind a suitable set screw flat (approximate dimensions; 8 mm by 4 mm by 0.5 mm) on the periphery of each bearing race;<sup>8</sup> flat must be square with face to prevent cocking of races when set screws are tightened.

NOTE 3—It is extremely difficult to grind the flat square with the face when using a hand or bench grinder. Good results have been obtained by racking a number of bearing races in a V-block and using a surface grinder.

8.2 Scribe suitable identification marks on the outer lands of bearing races to distinguish races of upper bearing from races of lower bearing. Identification marks should not be scribed on back or periphery of the bearing race.

8.3 Fill tank of ultrasonic cleaner with distilled water to a depth of 30 mm to 40 mm. Place two bearing sets in a 250 mL beaker containing about 125 mL of *n*-heptane. Cover beaker and place in ultrasonic bath. After cleaning for 10 min to

15 min, transfer bearing parts to second beaker containing 125 mL of *n*-heptane (see 7.2). Clean for 8 min to 10 min, then repeat operation for two additional 4 min to 5 min washes, using new *n*-heptane and clean beakers each time.

8.4 Place bearing parts onto freshly cleaned, glass Petri dishes or aluminum moisture dishes to air dry. Bearings should be propped against rim of dish to permit air circulation. Clean bearings must not be rotated or air blown. Do not place bearings on any surface other than freshly cleaned glass or metal. Do not touch bearings with bare hands; use forceps or tongs, or wear surgical gloves or finger cots.

8.5 When bearings are dry, place dishes containing bearings in a desiccator and let stand for a minimum of 30 min.

8.6 Weigh the upper and lower bearing race pairs separately to the nearest 0.1 mg. (Each race pair consists of two races.)

## 9. Procedure

9.1 In a dust-free environment, install the test grease in unused, cleaned, weighed bearings.

9.1.1 Fill the ball tracks of the bearing races with the test grease. Use a suitable spatula to strike the grease level with the bearing lands. Bearing backs and bearing seats must be kept free of grease and particulate matter. Clean with a lint-free cloth slightly moistened with *n*-heptane.

9.1.2 Fill each ball retainer with test grease taking care to fill all the cavities around the balls on both sides of the retainer. Remove excess grease from the bore and rim of the retainer, but leave an excess of grease on the cupped side. Adjust the mass of the grease in each bearing to 1.0 g ± 0.05 g.

9.2 Assemble the chuck. A suggested procedure for chuck assembly is described in 9.2.1 – 9.2.7. Use Fig. 5 as a guide to chuck assembly. Use minimal force when tightening set screws. Locate bearing set screw flats normal to set screws. Purpose of set screws is to prevent rotation of races in seats. To preclude overtightening set screws, grasp hex-key (Allen wrench) by shank rather than by lever arm. If set screws tend to loosen during the test, use a low-strength anaerobic sealant (MIL-S-22473D, Grade H or similar) on the threads rather than more force. Bearing races must bottom on bearing seats. Bottoming can be verified by visual and tactile inspection. (Warning—Tight set screws, misalignment between set screws and flats, or set screw flats that are not square with the bearing face can cock the bearing upon tightening set screws, causing uneven wear. Loose set screws combined with oily or greasy bearing backs and seats could allow a poor grease to give erroneous test results because of race creep effects.)

9.2.1 Preassemble upper bearing races and bearing retainer with the flats aligned and the cupped side of the bearing retainer positioned so it will face upward during assembly (downward during operation).

9.2.2 Install preassembly in the chuck top, ensuring that the flats are aligned with the set screw and the bearing race is bottomed on the bearing seat. Tighten the race set screw using minimal force.

9.2.3 Invert the chuck top and secure in a bench vise.

9.2.4 Install the oscillating bearing seat on the shaft such that the upper bearing components are properly aligned and

<sup>12</sup> Reagent Chemicals, American Chemical Society Specifications, American Chemical Society, Washington, DC. For suggestions on the testing of reagents not listed by the American Chemical Society, see *Analar Standards for Laboratory Chemicals*, BDH Ltd., Poole, Dorset, U.K., and the *United States Pharmacopeia and National Formulary*, U.S. Pharmacopeial Convention, Inc. (USPC), Rockville, MD.

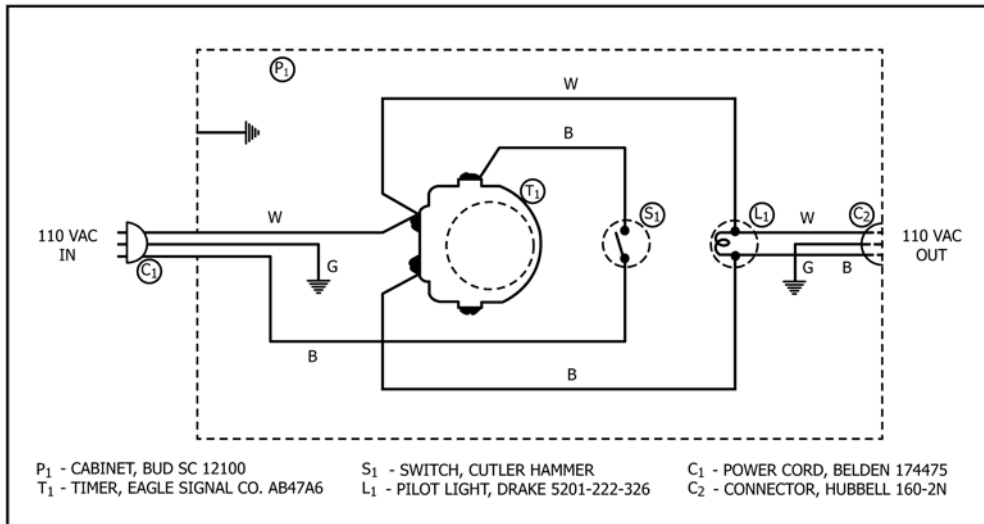

FIG. 4 Time Switch Circuit

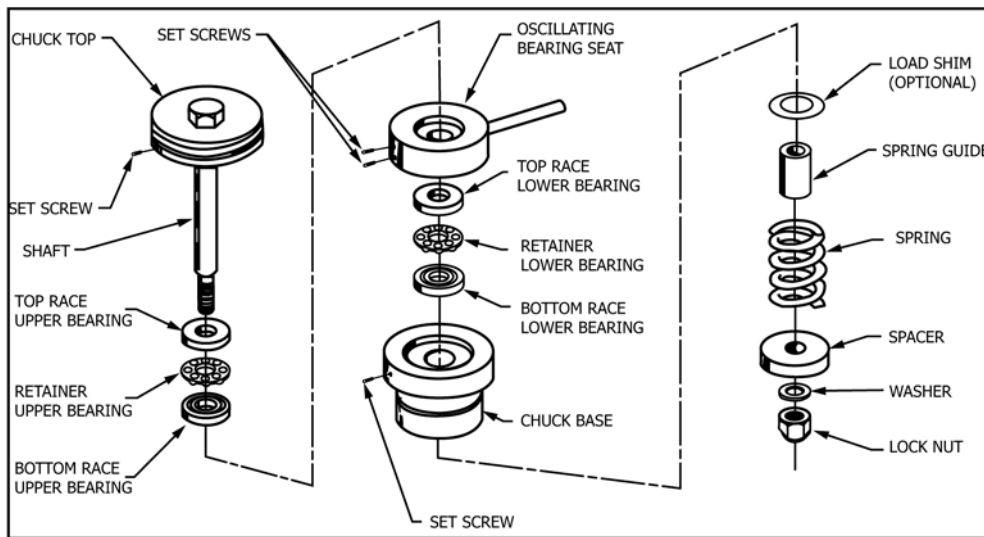

FIG. 5 Exploded View of Chuck Assembly

mated. Using minimal force, tighten the set screw. (With all bearing set screws oriented alike, permanently mark the underside of the oscillating bearing seat crank arm. Thereafter, when using the same orientation for assembly the lower bearing race will always be installed in the same seat.)

9.2.5 Preassemble the lower bearing as described in 9.2.1.

9.2.6 Install the preassembled lower bearing into the oscillating bearing seat, ensuring that the flats are aligned with the set screw and the bearing race is bottomed on the bearing seat. Tighten the race set screw using minimal force.

9.2.7 Place the chuck base on the shaft, ensuring that the flats are aligned with the set screw and the bearing race is bottomed on the bearing seat. Tighten the race set screw using minimal force.

9.2.8 Install the other lower bearing race in the chuck base. Using minimal force tighten the set screw.

9.2.9 Place the chuck base on the shaft.

9.2.10 Assemble the spring guide, spring, load shim (if required), spacer, washer, and lock nut on the shaft. While holding the chuck base and oscillating bearing seat to prevent rotation, tighten the lock nut until the spacer bottoms on the shaft shoulder.

NOTE 4—Spring alignment may affect wear pattern. To ensure consistent spring alignment, paint a reference mark on the (cleaned) spring and thereafter, always install spring with mark aligned with the set screw in the chuck base.

9.2.11 Remove chuck assembly from vise. Loosen all bearing race set screws. While holding chuck base in one hand, strike head of shaft with a 0.5 kg (1 lb) (approximate) soft-faced hammer to assist bearing seating. Lightly tighten all set screws.

9.2.12 Apply a film of grease to the surfaces of the chuck that contact the housing.

NOTE 5—Use any low-fretting wear grease.

9.2.13 Place the chuck in the housing with the chuck firmly seated against the housing shoulder. Tighten the set screw in the side of the housing.

NOTE 6—Some chuck bases (Fig. 5) have been supplied without a set screw flat. If the chuck base does not have a flat, grind flat, approximate dimensions, 9.5 mm by 9.5 mm by 0.5 mm ( $\frac{3}{8}$  in. by  $\frac{3}{8}$  in. by 0.02 in.), corresponding to set screw in housing (Fig. 2, left side).

9.2.14 Attach the connecting rod to the arm of the oscillating bearing seat. Apply a drop of lubricating oil to each connecting-rod end bearing (Note 5). Install the connecting-arm guard.

NOTE 7—With prolonged usage, certain tester parts may wear or deteriorate. Check rod end bearings for wear prior to each test. Replace with new bearings<sup>13,7</sup> at the first sign of looseness. Frequent lubrication (automatic transmission fluid is suitable) will prolong bearing life. Check Quad-ring or O-ring in chuck top for swelling or other deterioration. If necessary, replace with new Quad-ring.<sup>14,7</sup>

9.3 Place tester on vibration mount.

NOTE 8—Tester may be placed on full sheet of vibration pad<sup>10,7</sup> (or equivalent) but more economical use of pad and better vibration control can be achieved by placing suitability sized (approximately 75 by 75 mm) sections under each tester foot. Vibration control will be improved if grain of pads is alternated.

9.4 Run the test for 22 h  $\pm$  0.1 h by setting the time switch and the ON-OFF switch. The test will terminate automatically.

9.5 At the end of the test, disassemble the machine and remove all bearing components from the chuck.

9.6 Remove the bulk of the grease from the bearings with a clean, soft cloth.

9.7 Clean the bearings as outlined in 8.3.

9.8 Weigh the bearings as outlined in 8.4.

9.9 Calculate mass losses of upper race pair and lower race pair. Do not include mass loss of balls and retainers. Calculate the mean of the upper and lower mass losses.

9.10 Calculate the mass loss ratio by dividing the mass loss of the upper race pair by that of the lower race pair.

## 10. Report

10.1 Report, as mean mass loss, the mean, to one-tenth mg, of the two mass losses determined in 9.10.

## 11. Precision and Bias<sup>9</sup>

11.1 The precision of the mean mass losses as determined by the statistical examination of interlaboratory test results is as follows:

<sup>13</sup> Fafnir REB-3N or equivalent has been found satisfactory.

<sup>14</sup> Quad-ring No. Q4277, 54 mm by 60 mm by 3 mm ( $2\frac{1}{8}$  in. by  $2\frac{3}{8}$  in. by  $\frac{1}{8}$  in.), available from rubber goods suppliers, has been found satisfactory.

**TABLE 1 Repeatability and Reproducibility**

Average Value, mg	Repeatability, mg	Reproducibility, mg
5	3.1	6.7
10	4.4	9.5
20	6.3	13.4
40	8.8	19.0

NOTE 9—The data used to develop the precision statement were obtained from cooperative tests using *n*-hexane and chloroform instead of the prescribed solvents. *n*-Heptane and 1,1,1-trichloroethane were then used instead of the original solvents because of their less hazardous nature and experience indicated that test results were unaffected. However, 1,1,1-trichloroethane manufacture has ceased because of environmental and health concerns. A limited recent study indicates that test results are not affected by elimination of this solvent from the bearing cleaning procedure and instead using *n*-heptane only.

11.1.1 *Repeatability*—The difference between two test results, obtained by the same operator with the same apparatus under constant operating conditions on identical test material would, in the long run, in the normal and correct operation of the test method, exceed the following values only in one case in twenty (see Table 1).

$$\text{Repeatability} = 1.4 \sqrt{x} \quad (1)$$

where  $x$  = average mean mass losses of two tests in milligrams.

11.1.2 *Reproducibility*—The difference between two single and independent results obtained by different operators working in different laboratories on identical test material would, in the long run, in the normal and correct operation of the test method, exceed the following values only in one case in twenty.

$$\text{Reproducibility} = 3.0 \sqrt{x} \quad (2)$$

where  $x$  = average mean mass losses of two tests in milligrams.

11.1.3 The mass loss ratios are not subject to precision analysis. However, mass loss ratios were determined in the interlaboratory test program. The following ranges of mass loss ratios were observed:

	Ratio Range
Center 90 %	0.56 to 3.27
Center 80 %	0.61 to 1.90
Center 50 %	0.73 to 1.26

11.2 *Bias*—The procedure in this test method has no bias because the value of fretting wear can be defined only in terms of a test method.

## 12. Keywords

12.1 Fafnir test; false brinelling; fretting corrosion; fretting wear; friction oxidation; grease; lubricating grease; oscillating wear test; wear

**SUMMARY OF CHANGES**

Subcommittee D02.G0 has identified the location of selected changes to this standard since the last issue (D4170 – 10) that may impact the use of this standard. (Dec. 1, 2016.)

(1) Revised **9.2.**

*ASTM International takes no position respecting the validity of any patent rights asserted in connection with any item mentioned in this standard. Users of this standard are expressly advised that determination of the validity of any such patent rights, and the risk of infringement of such rights, are entirely their own responsibility.*

*This standard is subject to revision at any time by the responsible technical committee and must be reviewed every five years and if not revised, either reapproved or withdrawn. Your comments are invited either for revision of this standard or for additional standards and should be addressed to ASTM International Headquarters. Your comments will receive careful consideration at a meeting of the responsible technical committee, which you may attend. If you feel that your comments have not received a fair hearing you should make your views known to the ASTM Committee on Standards, at the address shown below.*

*This standard is copyrighted by ASTM International, 100 Barr Harbor Drive, PO Box C700, West Conshohocken, PA 19428-2959, United States. Individual reprints (single or multiple copies) of this standard may be obtained by contacting ASTM at the above address or at 610-832-9585 (phone), 610-832-9555 (fax), or [service@astm.org](mailto:service@astm.org) (e-mail); or through the ASTM website ([www.astm.org](http://www.astm.org)). Permission rights to photocopy the standard may also be secured from the Copyright Clearance Center, 222 Rosewood Drive, Danvers, MA 01923, Tel: (978) 646-2600; <http://www.copyright.com/>*