



Standard Test Methods for Shellac Used for Electrical Insulation¹

This standard is issued under the fixed designation D 411; the number immediately following the designation indicates the year of original adoption or, in the case of revision, the year of last revision. A number in parentheses indicates the year of last approval. A superscript epsilon (ϵ) indicates an editorial change since the last revision or reapproval.

1. Scope

1.1 These test methods cover tests for shellac in the dry button or powder form to be used for electrical insulating purposes. Typically, shellac is used as a bonding agent for mica splittings and reconstituted mica paper products, or as a coating or adhesive for other material.

1.2 *This standard does not purport to address all of the safety concerns, if any, associated with its use. It is the responsibility of the user of this standard to establish appropriate safety and health practices and determine the applicability of regulatory limitations prior to use.*

NOTE 1—There is no similar or equivalent IEC standard.

2. Referenced Documents

2.1 ASTM Standards:²

- D 29 Test Methods for Sampling and Testing Lac Resins
- D 1711 Terminology Relating to Electrical Insulation
- D 5032 Practice for Maintaining Constant Relative Humidity by Means of Aqueous Glycerine Solutions
- D 6054 Practice for Conditioning Electrical Insulating Materials for Testing
- E 104 Practice for Maintaining Constant Relative Humidity by Means of Aqueous Solutions

3. Terminology

3.1 *Definitions:* For definitions of terms used in this standard, refer to Terminology D 1711.

4. General Tests

4.1 Each of the following tests shall be made in accordance with the procedures described in Test Methods D 29:

- 4.2 Sampling,
- 4.3 Insoluble Matter,

- 4.4 Iodine Number,
- 4.5 Moisture Content,
- 4.6 Wax,
- 4.7 Ash, and
- 4.8 Orpiment (Native arsenic trisulfide).

POLYMERIZATION TIME

5. Significance and Use

5.1 Polymerization time provides a measure of time during which shellac retains its plasticity and flow properties at the specified temperature before gelling or polymerizing to the tough rubbery insoluble form. This test is important in determining the quality of different lots, useful shelf-life, batch uniformity, and processing characteristics of shellac.

6. Apparatus

6.1 *Test Tubes and Wire Rack*—Two 18-mm outside diameter glass test tubes, supported by a wire rack to a depth of 100 mm when placed in an oil bath. The test tubes must be supported and maintained in a vertical position. The rack shall be constructed so as to permit free circulation of oil around the test tubes.

6.2 *Oil Bath*—The oil bath shall be constructed with heaters, temperature control, and means of circulation to maintain the oil or other liquid at a temperature of $150 \pm 1^\circ\text{C}$ at all points within the bath. The oil or other liquid used shall be appropriate for the design of the bath and for safety at the test temperature. The bath shall be equipped with a thermometer, or other indicator or recorder, to indicate the oil temperature within $\pm 1^\circ\text{C}$.

6.3 *Glass Rod*—A smooth glass rod about 3 mm in diameter and approximately 200 mm long. The end of the glass rod which is to be immersed in the shellac shall be fire polished to a smooth round end.

NOTE 2—A smooth glass rod about 5 mm in diameter and approximately 200 mm long with an indicator mark at the top to indicate movement may be used. Flatten slightly the diameter of the glass rod for approximately 3 mm length at the end which is immersed in the shellac. The purpose of the flattened rod is to provide a more positive feel of the twist back and rubbery character at the end point. If this alternative is used, it must be specified in the report.

¹ These methods are under the jurisdiction of ASTM Committee D09 on Electrical and Electronic Insulating Materials and are the direct responsibility of Subcommittee D09.01 on Electrical Insulating Varnishes, Powders, and Encapsulating Compounds.

Current edition approved Nov. 10, 1998. Published January 1999. Originally approved in 1935. Last previous edition approved in 1998 as D 411 – 98.

² For referenced ASTM standards, visit the ASTM website, www.astm.org, or contact ASTM Customer Service at service@astm.org. For *Annual Book of ASTM Standards* volume information, refer to the standard's Document Summary page on the ASTM website.



6.4 *Timer*, for indicating elapsed time in minutes and seconds.

7. Test Specimens

7.1 For each test specimen use 4.00 ± 0.01 g of shellac, dried as specified in 8.2.

7.2 Prepare two specimens from each sample.

8. Conditioning

8.1 Crush samples of shellac on clean paper, mix well, and then dry as described in 8.2.

8.2 For each sample to be tested, evenly spread 9 to 10 g of the sample in a flat-bottom dish about 50 mm in diameter. Desiccate over anhydrous calcium chloride for at least 24 h at room temperature, or dry in a forced-convection oven at a temperature of $40 \pm 2^\circ\text{C}$ for 16 to 20 h.

8.3 After drying, immediately transfer the sample to a clean, dry, tightly stoppered bottle, and allow to cool. Do not open the bottle except when a specimen is being removed for test.

9. Procedure

9.1 Transfer a specimen of shellac from the stoppered bottle to the 18-mm glass test tube. Insert the tube and hold securely in a vertical position in the test rack. Place the rack in the oil bath having a test temperature of $150 \pm 1^\circ\text{C}$ maintained throughout the test.

9.2 Start the timer when the test tube enters the oil bath.

9.3 Using the glass rod, stir the specimen gently until the specimen melts, but not for more than 3 min. Do not stir after 3 min.

9.4 Beginning 4 min after immersion of the test tube, and at the end of each subsequent minute, give the glass rod a slight twist, turning approximately 90° each time. In the early stages of the test, and before the polymerization point is reached, the glass rod will remain in the position to which it has been turned. When, however, the shellac takes on a rubbery set, there will be a definite turning or twisting back of the rod following the 90° twist. This is the end point.

NOTE 3—In the early stages of the test there may be a tendency for the glass rod to move back slowly after twisting with the fingers. This slight movement should not be confused with the definite “twist-back” observed when the end point is reached.

10. Polymerization Time

10.1 Record as the polymerization time, the elapsed time in minutes, from the time of entry of the specimen into the bath and including the 3-min stirring period, until the first “twist-back” of the glass rod is noted.

11. Report

11.1 Report the following information:

11.1.1 The polymerization time in minutes for each specimen, and

11.1.2 The average of the values in 11.1.1.

12. Precision and Bias

12.1 This test method has been in use for many years, and no determination of precision has been made, and no work is planned to develop such information.

12.2 This test method has no bias, because the test values are defined solely in terms of this method.

FLOW TEST

13. Summary of Test Methods

13.1 These tests determine the flow of shellac when subjected to $100 \pm 1^\circ\text{C}$ under the conditions of test specified herein. These methods consist of melting a specimen of ground shellac in a graduated test tube and then tilting the tube to a specified angle while maintained at $100 \pm 1^\circ\text{C}$ in order to permit the shellac to flow down the tube.

13.2 Two methods are provided as follows:

13.2.1 *Method A*—In this method the time required for the shellac to flow specified distances along the test tube is measured, and

13.2.2 *Method B*—In this method the total distance the shellac flows along the test tube in a specified time is measured.

14. Significance and Use

14.1 The rate at which shellac flows down an inclined plane under standard conditions can be used to determine the flow variation that occurs between different types, grades, or lots of shellac.

14.2 Flow tests are sensitive to atmospheric conditions, the flow being greater under humid conditions, and less with low humidity. It is essential to carry out the tests in a conditioned atmosphere or as quickly as possible after removal from the conditioning atmosphere so as to minimize errors due to the effects of atmospheric conditions.

15. Apparatus

15.1 Suitable apparatus for both Methods A and B are described in Annex A1.

15.2 Any apparatus that will provide for accurate temperature control, correct positioning of the test tubes, and for visual observation of flow when required may be used.

16. Conditioning

16.1 For each specimen use 2.0 ± 0.1 g of shellac, ground to pass a No. 20 sieve. Prepare two specimens from each sample.

16.2 Spread the specimens out in shallow vessels. Condition for at least 24 h in a standard laboratory atmosphere in accordance with Practice D 6054. Alternatively, condition for the same time in a desiccator over an aqueous glycerine solution adjusted to give 50 % relative humidity, in accordance with Practice D 5032, or over a saturated solution of magnesium nitrate (52.9 % relative humidity), in accordance with Practice E 104.

16.3 Test, in accordance with Section 18 or Section 21, in the standard atmosphere, or immediately upon removal of the specimens from the conditioned atmosphere specified in 16.2.

17. Preparation of Specimens

17.1 Place the two specimens of shellac in separate glass test tubes with care being taken that the specimen in each tube is at the bottom and that none of the powdered shellac adheres

to the walls of the glass tube. Read the top level of the dry shellac in each tube on the millimetre graduated scale. Clamp the tubes containing the specimens in place in the testing fixture (see Section 15 and Fig. A1.1).

17.2 Insert the testing fixture, with the glass test tubes in a vertical position, into the oil bath maintained at the test temperature of $100 \pm 1^\circ\text{C}$.

17.3 The top surface of the specimen in each tube should be level and at right angles to the walls of the tube.

17.4 Allow the specimens to melt for 3 min.

METHOD A

18. Procedure

18.1 At the end of the 3-min melting period, place each test tube at an angle of 15° from the horizontal, with the corked ends down (see 15.1 and Fig. A1.2), and with the breather tube extending above the level of the oil bath. Make the change from the vertical position to the flow position as quickly as possible. With the oil bath maintained at the test temperature of $100 \pm 1^\circ\text{C}$, record the total time required for the shellac in each tube to flow from the initial level of the shellac to each centimetre marking along the tube. Discontinue the test in each tube when the flow is 9 cm or the total time is 20 min.

19. Report

19.1 Report the following information, for tests using Method A:

19.1.1 The elapsed time for each centimetre of flow for each specimen;

19.1.2 A plot of the data reported in 19.1.1, with time as the abscissa and flow as the ordinate;

19.1.3 The angle of the test tubes during the test; and

19.1.4 The temperature and relative humidity of the atmosphere within which the test was conducted.

20. Precision and Bias

20.1 This test method has been in use for many years, and no determination of precision has been made, and no work is planned to develop such information.

20.2 This test method has no bias, because the test values are defined solely in terms of this method.

METHOD B

21. Procedure

21.1 At the end of the 3-min melting period, place each test tube at an angle of 15° from the horizontal, with the corked ends down (see 21.2 and Fig. A1.2) and with the breather tube extending above the level of the oil bath. Make the change from the vertical position to the flow position as quickly as possible. With the oil bath maintained at the test temperature of $100 \pm 1^\circ\text{C}$, allow the test tubes to remain in the bath in this position for 12.0 ± 0.1 min.

21.2 Remove the test tubes immediately, place in a vertical position, cool, wipe, and measure the flow of the shellac in each tube by reading the distance between the initial point and the end of the flow tongue. Disregard the “feather” at the very tip of the tongue.

NOTE 4—This “feather,” caused by separation of wax from the shellac, is more noticeable with some shellacs than with others. It can readily be distinguished from the main body of shellac as it is always of a different color.

22. Report

22.1 Report the following information for tests using Method B:

22.1.1 Flow, expressed in millimetres, for each specimen;

22.1.2 The average of the values in 22.1.1;

22.1.3 The angle of the test tubes during the test period; and

22.1.4 The temperature and relative humidity of the atmosphere within which the test was conducted.

23. Precision and Bias

23.1 This test method has been in use for many years, and no determination of precision has been made, and no work is planned to develop such information.

23.2 This test method has no bias, because the test values are defined solely in terms of this method.

24. Keywords

24.1 bonded mica; electrical insulation; flow; polymerization time; shellac

ANNEX

(Mandatory Information)

A1. DESCRIPTION OF APPARATUS FOR DETERMINING THE FLOW OF SHELLAC

A1.1 The apparatus shown in Fig. A1.1 and Fig. A1.2 is illustrative of what may be used to determine the flow of shellac. Other apparatus, differing in detail from that shown in the figures, may be used, but must include the following features and capabilities:

A1.1.1 *Test Tubes*— Two test tubes, A, 120 to 130 mm in length, 25 mm outside diameter, preferably graduated in 5 mm divisions, beginning 11 mm from the outside bottom and extending upward to 100 mm from the bottom.

A1.1.1.1 The test tubes shall be equipped with tightly-fitting stoppers, through which extend breather tubes, B.

A1.1.2 *Support*—A fixture, C, for holding the test tubes in the correct position, and allowing for insertion into and removal from the bath and for accurate rotation of the axes of the tubes to the proper angle.

A1.1.3 *Oil Bath*—A bath of the proper size to accommodate the fixture with the test tubes, and capable of maintaining a temperature of $100 \pm 1^\circ\text{C}$ at all points in the bath during the period of the test.

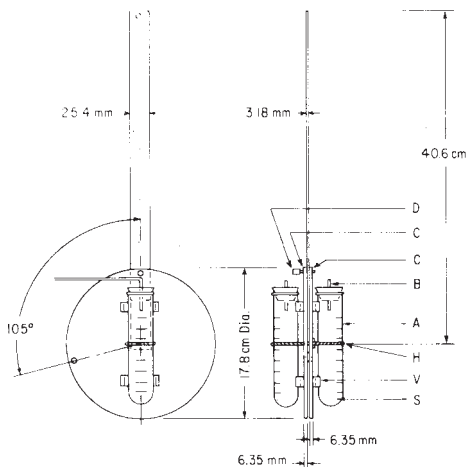

FIG. A1.1 Flow Test Fixture Showing Essential Parts with Test Tubes in Vertical Position

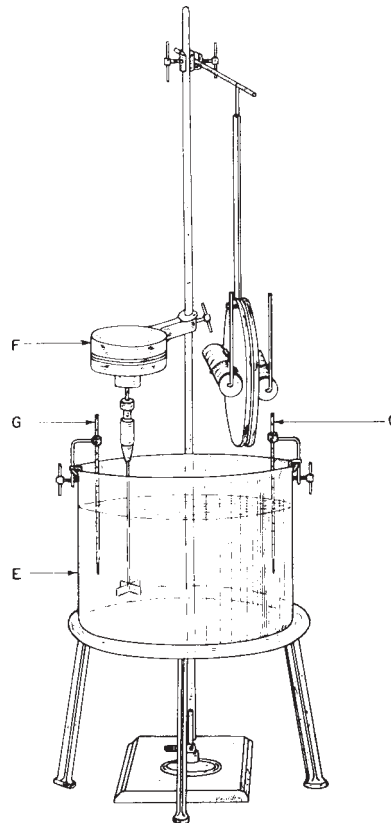

FIG. A1.2 Apparatus Arranged with Tubes in Inclined Position for Immersion in Bath for Flow Test

A1.1.3.1 The bath shall be equipped with a temperature indicator or recorder calibrated to the precision specified above.

A1.1.3.2 The liquid used shall have a sufficiently high flash point to operate safely at the test temperature.

A1.1.3.3 If Method A is to be used, the construction of the bath and the selection of the liquid in the bath shall be such as to permit the required visual observations.



D 411 – 98 (2003)

ASTM International takes no position respecting the validity of any patent rights asserted in connection with any item mentioned in this standard. Users of this standard are expressly advised that determination of the validity of any such patent rights, and the risk of infringement of such rights, are entirely their own responsibility.

This standard is subject to revision at any time by the responsible technical committee and must be reviewed every five years and if not revised, either reapproved or withdrawn. Your comments are invited either for revision of this standard or for additional standards and should be addressed to ASTM International Headquarters. Your comments will receive careful consideration at a meeting of the responsible technical committee, which you may attend. If you feel that your comments have not received a fair hearing you should make your views known to the ASTM Committee on Standards, at the address shown below.

This standard is copyrighted by ASTM International, 100 Barr Harbor Drive, PO Box C700, West Conshohocken, PA 19428-2959, United States. Individual reprints (single or multiple copies) of this standard may be obtained by contacting ASTM at the above address or at 610-832-9585 (phone), 610-832-9555 (fax), or service@astm.org (e-mail); or through the ASTM website (www.astm.org).