



Standard Practice for Shake Extraction of Solid Waste with Water¹

This standard is issued under the fixed designation D3987; the number immediately following the designation indicates the year of original adoption or, in the case of revision, the year of last revision. A number in parentheses indicates the year of last reapproval. A superscript epsilon (ϵ) indicates an editorial change since the last revision or reapproval.

1. Scope

1.1 This practice covers a procedure for leaching of solid waste to obtain an aqueous solution to be used to determine the constituents leached under the specified testing conditions.

1.2 This practice provides for the shaking of a known mass of waste with water of specified composition and the separation of the aqueous phase for analysis.

1.3 The values stated in SI units are to be regarded as standard. Values given in parentheses are mathematical conversions to inch-pound units that are provided for information only and are not considered standard.

1.4 *This standard does not purport to address all of the safety problems, if any, associated with its use. It is the responsibility of the user of this standard to establish appropriate safety and health practices and determine the applicability of regulatory limitations prior to use.*

2. Referenced Documents

2.1 *ASTM Standards:*²

[C471M Test Methods for Chemical Analysis of Gypsum and Gypsum Products \(Metric\)](#)

[D75 Practice for Sampling Aggregates](#)

[D420 Guide to Site Characterization for Engineering Design and Construction Purposes \(Withdrawn 2011\)](#)³

[D1193 Specification for Reagent Water](#)

[D2216 Test Methods for Laboratory Determination of Water \(Moisture\) Content of Soil and Rock by Mass](#)

[D2234/D2234M Practice for Collection of a Gross Sample of Coal](#)

[D3370 Practices for Sampling Water from Closed Conduits](#)

[D5681 Terminology for Waste and Waste Management](#)

¹ This practice is under the jurisdiction of ASTM Committee D34 on Waste Management and is the direct responsibility of Subcommittee D34.01.04 on Waste Leaching Techniques.

Current edition approved Nov. 1, 2012. Published November 2012. Originally approved in 1981. Last previous edition approved in 2006 as D3987 – 06. DOI: 10.1520/D3987-12.

² For referenced ASTM standards, visit the ASTM website, www.astm.org, or contact ASTM Customer Service at service@astm.org. For *Annual Book of ASTM Standards* volume information, refer to the standard's Document Summary page on the ASTM website.

³ The last approved version of this historical standard is referenced on www.astm.org.

[E122 Practice for Calculating Sample Size to Estimate, With Specified Precision, the Average for a Characteristic of a Lot or Process](#)

3. Definitions

3.1 For definitions of terms used in this practice, see Terminology [D5681](#).

4. Significance and Use

4.1 This practice is intended as a rapid means for obtaining an extract of solid waste. The extract may be used to estimate the release of constituents of the solid waste under the laboratory conditions described in this procedure.

4.2 This practice is not intended to provide an extract that is representative of the actual leachate produced from a solid waste in the field or to produce extracts to be used as the sole basis of engineering design.

4.3 This practice is not intended to simulate site-specific leaching conditions. It has not been demonstrated to simulate actual disposal site leaching conditions.

4.4 The intent of this practice is that the final pH of the extract reflects the interaction of the extractant with the buffering capacity of the solid waste.

4.5 The intent of this practice is that the water extraction simulates conditions where the solid waste is the dominant factor in determining the pH of the extract.

4.6 The practice produces an extract that is amenable to the determination of both major and minor constituents. When minor constituents are being determined, it is especially important that precautions are taken in sample storage and handling to avoid possible contamination of the samples.

4.7 The practice has not been tested for applicability to organic substances and volatile matter.

5. Apparatus

5.1 *Agitation Equipment*, of any type that rotates about a central axis at a rate of 29 ± 2 r/min and mixes samples in an end-over-end fashion (see example equipment in [Fig. 1](#).)

NOTE 1—Modifications to the agitation technique (orientation or rate) could result in alteration of the degree of mixing or the rate of release of constituents as well as causing particle abrasion. As a result, the precision of the practice may also be influenced.

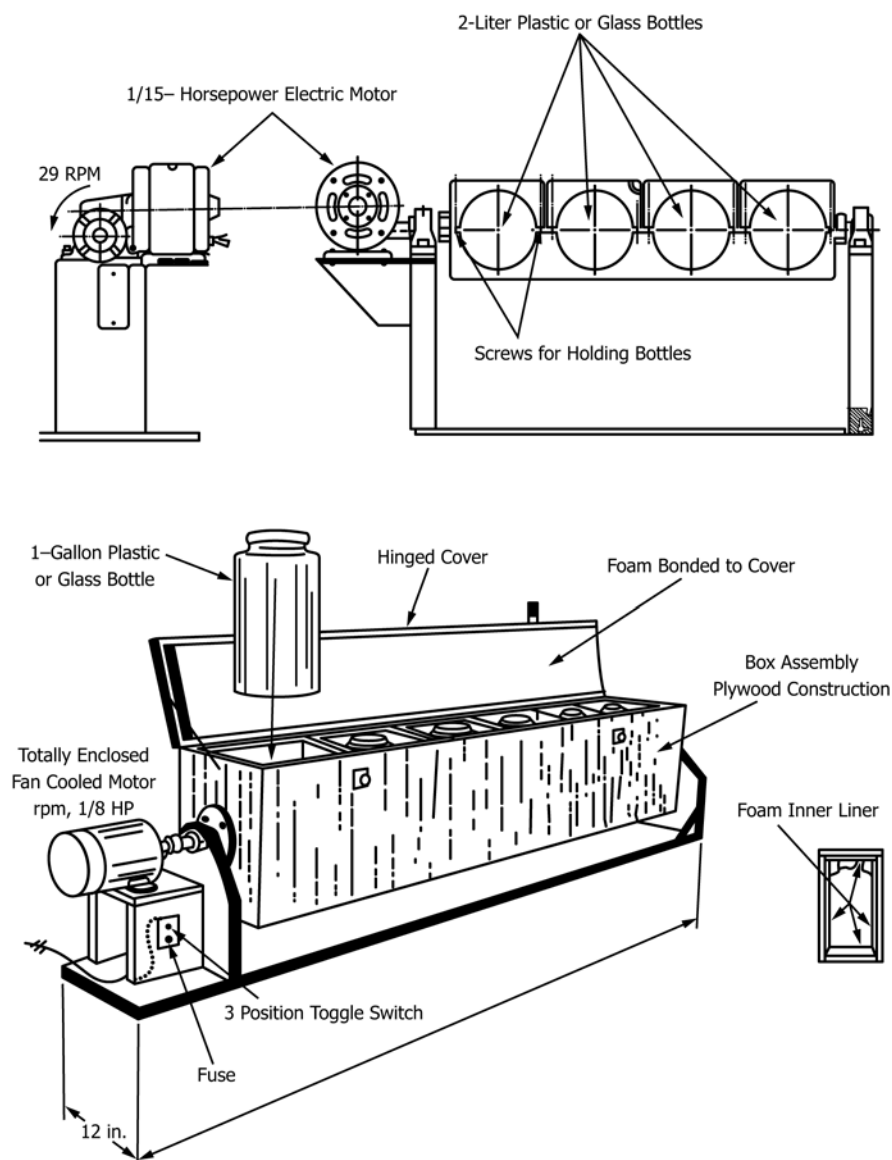

FIG. 1 Example Extractor

5.2 *Membrane Filter Assembly*—A borosilicate glass or stainless steel funnel with a flat, fritted base of the same material and membrane filters.

5.3 *Containers*, round, wide-mouth, of a composition suitable to the nature of the solid waste and the analyses to be performed, and constructed of materials that will not allow sorption of constituents of interest.

5.3.1 Containers should be of sufficient size to contain the mass of the solid sample plus the volume of extractant at a liquid-to-solid ratio of 20 mL/g, leaving approximately 10-20 % headspace for mixing. For example, 2-L (0.5 gal) containers may be used for 70-g (0.15 lb) samples with 1400 mL (0.37 gal) of extractant, while 4-L (1 gal) containers may be required for 140-g (0.30 lb) samples with 2800 mL (0.74 gal) of extractant.

5.3.2 Containers must have watertight closures.

5.3.3 Containers with venting mechanisms should be provided for samples where gases may be released.

NOTE 2—Allowing the container to vent generated gases has the potential to affect the concentrations of constituents in the extract.

5.3.4 Containers should be cleaned in a manner consistent with the analyses to be performed.

5.4 *Laboratory Balance*, capable of accurately measuring 0.01 g.

5.5 *pH Meter*, with temperature compensation, readability of 0.01 units and an accuracy of ± 0.05 units at 25°C.

6. Reagents

6.1 *Purity of Reagents*—Reagent grade chemicals shall be used. Unless otherwise indicated, it is intended that all reagents shall conform to the specifications of the American Chemical Society, where such specifications are available. Other grades may be used, provided it is first ascertained that the reagent is of sufficiently high purity to permit its use without lessening the accuracy of the determination.

6.2 *Purity of Water*—Unless otherwise indicated, references to water shall be understood to mean Type IV reagent water at 18 to 27°C (Specification **D1193**). The method by which the Type IV water is prepared, that is, distillation, ion exchange, reverse osmosis, electro dialysis, should remain constant throughout testing.

7. Sampling

7.1 Obtain a representative sample of the solid waste to be tested using ASTM sample methods developed for the specific industry where available. (See Practices **D75** and **D420** and Test Methods **D2234/D2234M**.)

7.2 Where no specific methods are available, sampling methodology for materials of similar physical form shall be used.

7.3 A minimum sample of 5 kg shall be sent to the laboratory (see Practice **E122**).

7.4 It is important that the sample of the solid waste be representative with respect to surface area, as variations in surface area would directly affect the leaching characteristics of the sample. Solid waste samples should contain a representative distribution of particles sizes.

7.5 Keep samples in closed containers appropriate to the sample type prior to the extraction in order to prevent sample contamination or constituent loss. Where it is desired to extract biologically or chemically active samples in their existing state, store the samples at 4°C (Practices **D3370**) and start the extraction within 8 h. Where it is desired to extract such samples in a state representative of the results of biological or chemical activities, the samples may be specifically handled to simulate such activities. Record the storage conditions and handling procedures in the report.

8. Sample Preparation

8.1 For free-flowing particulate solid wastes, obtain a sample of the approximate size required in the practice by quartering the sample (Section 7) on an impermeable sheet of glazed paper, oil cloth, or other flexible material as follows:

8.1.1 Empty the sample container into the center of the sheet.

8.1.2 Flatten out the sample gently with a suitable straight-edge until it is spread uniformly to a depth at least twice the maximum particle diameter particle size.

8.1.3 Remix the sample by lifting a corner of the sheet and drawing it across, low down, to the opposite corner in a manner that the material is made to roll over and over and does not merely slide along. Continue operation with each corner, proceeding in a clockwise direction. Repeat this operation ten times.

8.1.4 Lift all four corners of the sheet towards the center and holding all four corners together, raise the entire sheet into the air to form a pocket for the sample.

8.1.5 Repeat **8.1.2**.

8.1.6 With a straightedge at least as long as the flattened mound of sample (such as a thin-edged yard stick), gently divide the sample into quarters. An effort should be made to

avoid using pressure on the straightedge sufficient to cause damage to the particles.

8.1.7 Discard alternate quarters.

8.1.8 If further reduction of sample size is necessary, repeat **8.1.3** through **8.1.7**. A minimum sample size of 70 g is recommended for each extraction. Additional samples should be provided for determination of solids content. If smaller samples are used in the practice, report this fact.

8.2 For field-cored solid wastes or castings produced in the laboratory, cut a representative section weighing approximately 70 or 140 g for testing, plus samples for determination of solids content. Shape the sample so that the leaching solution will cover the material to be leached.

8.3 For fluid solid wastes, mix thoroughly in a manner that does not incorporate air to assure uniformity before withdrawing the mass of sample required for the practice. Take samples for determination of solids content at the same time as the preparation of samples for the practice.

9. Procedure

9.1 Record the physical description of the sample to be tested including particle size so far as it is known.

9.2 *Solids Content*—Determine the solids content of two separate portions of the sample as follows:

9.2.1 Dry to constant mass two dishes or pans of size suitable to the solid waste being tested at $104 \pm 2^\circ\text{C}$. Cool in a desiccator and weigh. Record the value to ± 0.01 g.

9.2.2 Put an appropriately sized portion of sample of the solid waste to be tested into each pan. Scale the mass used to the physical form of the solid waste tested. Use a minimum of 50 g but use larger samples where particles larger than 10-mm in average diameter are being tested. Weigh. Record the mass to ± 0.01 g.

9.2.3 Dry for an interval of approximately 18 h at $104 \pm 2^\circ\text{C}$. Certain solid wastes, such as scrubber sludges, may contain compounds that are subject to calcination at the specified drying temperature. Dry these compounds at lower temperatures. For example, gypsum may be successfully dried at 45°C (Test Methods **C471M**) and $\text{CaSO}_3 \cdot 1/2\text{H}_2\text{O}$ wastes at 85°C . Record the actual temperature and time of the drying period.

9.2.4 Cool to room temperature in a desiccator and reweigh. Record the mass to ± 0.1 g.

9.2.5 Repeat **9.2.3** until constant dried mass is established (e.g., two consecutive measures within 0.05 g).

9.3 *Shake Procedure*—Tare the container to be used in the shake practice.

9.4 Add to the container 70 ± 0.1 g of solid waste (Section 8). Record the mass of sample used. If masses other than 70 g are used, note in the report.

9.5 Add to the container a volume of reagent water (**6.2**) equal in millilitres to 20 times the mass in grams of the sample used in **9.4**. See discussion of dilution ratio in Appendix (Example: 70 g sample = 1400 mL water).

9.6 Agitate continuously for 18 ± 0.25 h at $21 \pm 2^\circ\text{C}$.

9.7 Open the container. Observe and record any physical changes in the sample and leaching solution.

9.8 Let the sample settle for 5 min; then separate the bulk of the aqueous phase from the solid phase by decantation, centrifugation, or filtration through a coarse filter paper as appropriate. Then vacuum or pressure filter the liquid through a 0.45- μm filter. If the separation method results in prolonged filtering time, an 8- μm filter or other device may be used as a pre-filter. Record any deviations in the report.

9.9 The filtrate obtained in 9.8 is the extract mentioned elsewhere in this practice. Measure the pH of the extract immediately, then preserve the extract in a manner consistent with the chemical analysis or biological testing procedures to be performed (Practices D3370). If sufficient liquid phase is not available for the analyses, so indicate in the report and do not continue the procedure; or alternatively, perform the extraction procedure on additional samples of the solid waste to obtain sufficient liquid phase. Where phase separation occurs during the storage of the extract, appropriate mixing should be used to ensure the homogeneity of the extract prior to its use in such analysis or testing.

9.10 Analyze the extract for specific constituents or properties or use the extract for biological testing procedures as desired using appropriate ASTM standard methods. Where no appropriate ASTM methods exist, other methods may be used and recorded in the report.

10. Calculation

10.1 Calculate the solids content of the individual samples from the data obtained in 9.2 as follows:

$$S = A/B \quad (1)$$

where:

A = mass in grams of sample after drying,
 B = original mass in grams of sample, and
 S = solid content, g/g.

Average the two values obtained and record as the solids content.

11. Report

11.1 The report shall include the following:

11.1.1 Source of the solid waste, date of sampling, and sample preservation used,

11.1.2 Description of the solid waste including physical characteristics and particle size, if known (9.1),

11.1.3 Solids content (9.2) (see Test Method D2216),

11.1.4 Sample mass if other than 70 g,

11.1.5 Drying time and temperature if other than 16 to 20 h at $104 \pm 2^\circ\text{C}$,

11.1.6 pH and results of specific analyses calculated in appropriate units. State analytical procedures used, and filter used if other than 0.45 μm .

11.1.7 State analytical procedures used, and filter used if other than 0.45 μm .

11.1.8 Observation of changes in test material or leaching solution recorded in 9.8.

11.1.9 Date leach testing started, preservation used for extract, and date of analysis.

ASTM International takes no position respecting the validity of any patent rights asserted in connection with any item mentioned in this standard. Users of this standard are expressly advised that determination of the validity of any such patent rights, and the risk of infringement of such rights, are entirely their own responsibility.

This standard is subject to revision at any time by the responsible technical committee and must be reviewed every five years and if not revised, either reapproved or withdrawn. Your comments are invited either for revision of this standard or for additional standards and should be addressed to ASTM International Headquarters. Your comments will receive careful consideration at a meeting of the responsible technical committee, which you may attend. If you feel that your comments have not received a fair hearing you should make your views known to the ASTM Committee on Standards, at the address shown below.

This standard is copyrighted by ASTM International, 100 Barr Harbor Drive, PO Box C700, West Conshohocken, PA 19428-2959, United States. Individual reprints (single or multiple copies) of this standard may be obtained by contacting ASTM at the above address or at 610-832-9585 (phone), 610-832-9555 (fax), or service@astm.org (e-mail); or through the ASTM website (www.astm.org). Permission rights to photocopy the standard may also be secured from the ASTM website (www.astm.org/COPYRIGHT/).