



Standard Specification for Dimensional Tolerance of Thermosetting Glass-Reinforced Plastic Pultruded Shapes¹

This standard is issued under the fixed designation D3917; the number immediately following the designation indicates the year of original adoption or, in the case of revision, the year of last revision. A number in parentheses indicates the year of last reapproval. A superscript epsilon (ϵ) indicates an editorial change since the last revision or reapproval.

1. Scope*

1.1 This specification defines production tolerances applicable to standard rods, bars, shapes, and flat sheet pultruded from thermosetting glass-reinforced plastics.

1.2 These dimensional tolerances apply to all shapes specified as “standard” by the pultrusion industry.

1.3 Custom shapes and products designed for special applications may carry specific tolerances that vary from the standard.

1.4 The values stated in inch-pound units are to be regarded as standard. The values given in parentheses are mathematical conversions to SI units that are provided for information only and are not considered standard.

¹ This specification is under the jurisdiction of ASTM Committee D20 on Plastics and is the direct responsibility of Subcommittee D20.18 on Reinforced Thermosetting Plastics.

Current edition approved Oct. 1, 2015. Published October 2015. Originally approved in 1980. Last previous edition approved in 2015 as D3917 - 15. DOI: 10.1520/D3917-15A.

1.5 The following safety hazards caveat pertains only to the test methods portion, Section 4, of this specification: *This standard does not purport to address all of the safety concerns, if any, associated with its use. It is the responsibility of the user of this standard to establish appropriate safety and health practices and determine the applicability of regulatory limitations prior to use.*

NOTE 1—There is no known ISO equivalent to this standard.

2. Terminology

2.1 Definitions:

2.1.1 *camber*—the deviation of the edge or surface from a reference straight line with the weight of the pultrusion not minimizing the measurement.

2.1.2 *flat sheet*—a rectangular solid pultruded profile with a width of 12 in. up to and including 78 inches.

2.1.3 *mean wall thickness*—the average of two or more wall thickness measurements taken at multiple locations.

2.1.4 *straightness*—the upward deviation of a pultruded shape when resting on a flat surface measured in a manner that the weight of the pultruded part minimizes the deviation.

*A Summary of Changes section appears at the end of this standard

3. Dimensional Criteria

3.1 Cross-sectional dimensions for standard rods, bars, and shapes shall be prescribed in **Table 1**.

3.1.1 For die struck dimension, if the calculated tolerance as per above table is more than 0.094 in. (2.39 mm), then the die struck dimension tolerance shall be ± 0.094 in. (2.39 mm).

3.1.2 For wall thickness of open shapes and closed shapes and flatsheets of thickness under 0.125 in. (3.175 mm) dimensions, if the calculated tolerance as per above table is less than 0.01 in. (0.25 mm), the thickness tolerance shall be ± 0.01 in. (0.25 mm).

3.1.3 For wall thickness and flatsheets of thickness over 0.125 in. (3.175 mm) dimensions, if the calculated tolerance as per above table is more than 0.05 in. (1.27 mm), the thickness tolerance shall be ± 0.05 in. (1.27 mm).

3.2 Length tolerances for standard rods, bars, and shapes shall be as prescribed in **Table 2**.

3.3 Straightness tolerances shall be as prescribed in **Table 3** (also see 4.2).

TABLE 1 Cross-Sectional Dimensions—Standard Rods, Bars, and Shapes

A Die Struck Dimension ^{A, B}	B Wall Thickness ^B (Open Shape)	Solid Dimensions, \pm in. (mm)		C Wall Thickness ^B (Closed Shape)
		Thickness (Flat Sheets)		
		Thickness 0.125 (3.175) and under	Thickness over 0.125 (3.175)	
$\pm 4\%$ 0.094 (2.39) max	$\pm 10\%$ ± 0.010 (0.25) min	$\pm 15\%$ ± 0.010 (0.25) min	$\pm 10\%$ ± 0.050 (1.27) max	$\pm 20\%$ ± 0.010 (0.25) min

^AThe outside dimension of a part.

^BStandard pultruded section with dimension up to 36-in. (914-mm) diameter.

TABLE 2 Length—Standard Rods, Bars, Shapes, and Flat Sheet

	Allowable Deviation from Specified Length, +, – in. (+, – mm), except as noted		
	Length up to 8 ft (2.44 m) inclusive	Length over 8 to 24 ft (2.44 to 7.32 m) inclusive	Length over 24 ft (7.32 m)
	All Rods, Bars, and Shapes	+0.25, –0 (+6.35, –0)	+0.5, –0 (+12.7, –0)

TABLE 3 Straightness^A—Standard Bars, Rods, Shapes, and Flat Sheet

Product	Allowable Deviation (<i>D</i>) from Straight, in. (mm)		
	Specified Diameter (Rods)	Specified Thickness (Rectangles)	In Total Length of Piece
	Specified Width (Bars)	Minimum Thickness (Shapes)	
Rods and square, hexagonal, and octagonal bars	all	...	0.030 (2.5) \times length, ft (m)
Rectangular bars	Up to 1.499 (38.07), incl	Up to 0.094 (2.4), incl	0.050 (4.17) \times measured length, ft (m)
		0.095 (2.4) and over	0.040 (3.33) \times measured length, ft (m)
Shapes—Open	1.500 (38.10) and over	all	0.040 (3.33) \times measured length, ft (m)
Shapes—Closed	all	all	0.050 (4.17) \times measured length, ft (m)
Flat Sheet	all	all	0.030 (2.5) \times measured length, ft (m)

^AMeasured when weight of pultrusion minimizes the deviation by contact with flat surface.

3.4 Twist tolerances for bars and shapes shall be as prescribed in Table 4 (also see 4.3).

3.5 Flatness (flat surface) tolerances for bars, solid shapes, semihollow shapes, and flat sheet shall be as prescribed in Table 5.

3.6 Flatness (flat surface) tolerances of hollow shapes shall be as prescribed in Table 6.

TABLE 4 Twist^A—Standard Bars and Shapes

Product	Specified Width (Bars) Max Dimension (Shapes)	Specified Thickness (Rectangles) Minimum Thickness (Shapes)	Allowable Deviation from Straight, deg	
			In Lengths Up to 20 ft (6 m)	
Bars	all	all	1°/ft (1°/305 mm)	
Shapes-Open	all	all	1°/ft (1°/305 mm)	
Shapes-Closed	all	all	1°/ft (1°/305 mm); 7° max	

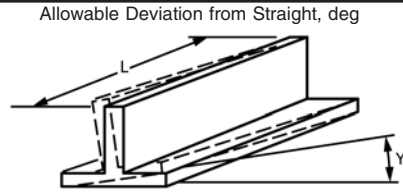

^AMeasured when weight of pultrusion minimizes the deviation by contact with flat surface.

TABLE 5 Flatness (Flat Surfaces)—Standard Bars, Solid Shapes, Semihollow Shapes, and Flat Sheet

Surface Width, in. (mm)	Maximum Allowable Deviation (D), in. (mm)
Up to 1 (25.4), incl	0.008 (0.20)
Over 1 (25.4)	0.008 (0.008) × W, in. (mm)
In any 1 in. (25.4 mm) of width	0.008 (0.20)
Flat Sheet	0.008 (0.008) × W, in. (mm)
	0.25 (6.35) Max

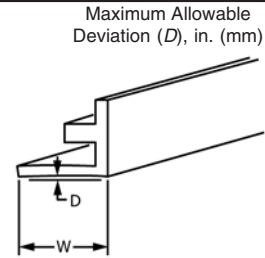
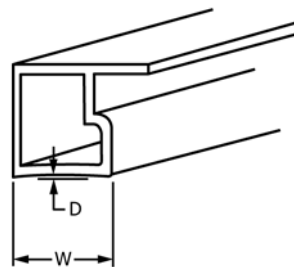

TABLE 6 Flatness (Flat Surfaces)—Standard Hollow Shapes

Minimum Thickness of Composite Forming the Surface, in. (mm)	Maximum Allowable Deviation (D), in. (mm)	
	Widths up to 1 in. (25.4 mm), incl, or any 1-in. (25.4-mm) Increment of Wider Surfaces	Widths over 1 in. (25.4 mm)
Up to 0.187 (4.7), incl	0.012 (0.30)	0.012 (0.012) × W, in. (mm)
0.188 (4.8) and over	0.008 (0.20)	0.008 (0.008) × W, in. (mm)



3.7 Angularity tolerances for bars and shapes shall be as prescribed in **Table 7** (also see 4.4).

3.8 Camber tolerances for shapes can be as prescribed in **Table 8**, if required by the customer. Camber is not specified for standard shapes but will be a special customer requirement.

3.9 The selection, type, and amount of reinforcements, as well as resin system used, directly affect dimensions. Tolerances shall be agreed upon between the supplier and the user.

3.10 Squareness of end cut for bars, solid shapes, semihollow shapes, and flat sheet shall be as prescribed in **Table 9**.

4. Test Methods

4.1 Obtain the specified tolerances with conventional measuring equipment. Measuring procedures, gages, and fixtures shall be agreed upon between the supplier and the user.

4.2 Measure departure from straightness by placing the section on a level table so that the arc or departure from straightness is vertical. Measure the vertical depth of the arc with a feeler gauge, a straightedge, or both.

4.3 Measure twist by placing the pultruded section on a flat surface and using an inclinometer. An inclinometer is a commercially available device used to measure the angle of inclination.

4.4 Measure angles with protractors or gauges.

5. Keywords

5.1 dimensional tolerance; pultruded shapes; thermosetting plastic

TABLE 7 Angularity—Standard Rods, Bars, and Shapes

Minimum Specified Leg Thickness, in. (mm)	Allowable Deviation from Specified Angle, ±°	
	Angles 90° or less	Angles more than 90°
Up to 0.749 (19.02), incl	2°	2°

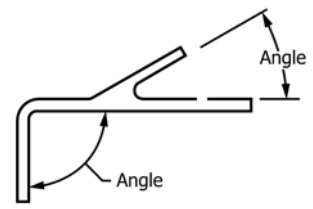
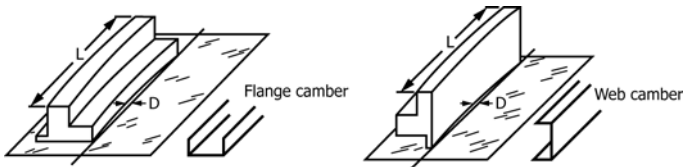

TABLE 8 Camber—Standard Shapes (See 3.8)



Product	Envelope Diameter (Shapes) in. (mm)	Minimum Thickness (Shapes) in. (mm)	Allowable Deviation (D) from Straight, in. (mm) In total length of piece
Shapes	All	Up to 0.094 (2.4), incl	0.050 (4.17) × measured length, ft (m)

TABLE 9 Squareness of End Cut—Standard Rods, Bars, Shapes, and Flat Sheet

Profiles over 2 in. (50.8 mm) in diameter or width	±1°
Profiles 2 in. (50.8 mm) inclusive and under in diameter or width	±2°

SUMMARY OF CHANGES

Committee D20 has identified the location of selected changes to this standard since the last issue (D3917 – 12) that may impact the use of this standard. (April 1, 2015)

- (1) Introduced tolerances for pultruded flat sheets.
- (2) Changed unilateral thickness tolerances to bilateral tolerances.
- (3) Changed the length tolerance from bilateral to unilateral tolerances.
- (4) Added tolerances for squareness of end cut.
- (5) Revised the definition of camber: camber—the deviation of the edge or surface from a reference straight line with the weight of the pultrusion not minimizing the measurement.
- (6) Changed note for **Table 1** to: The minimum tolerances are applicable for thicknesses less than 0.05 in (1.27 mm)
- (7) Eliminated the 1 degree footnote in **Table 7**.
- (8) Removed the web/flange camber drawing in **Table 8** as web and flange cambers cannot be combined.
- (9) Changed the spelling error from enclusive to inclusive in **Table 9**.
- (10) Modified metric conversions (where ever applicable) when a ratio was required to represent a tolerance allowable based on a deviation per length. In addition the mm/mm conversions that were not correct before were addressed.

ASTM International takes no position respecting the validity of any patent rights asserted in connection with any item mentioned in this standard. Users of this standard are expressly advised that determination of the validity of any such patent rights, and the risk of infringement of such rights, are entirely their own responsibility.

This standard is subject to revision at any time by the responsible technical committee and must be reviewed every five years and if not revised, either reapproved or withdrawn. Your comments are invited either for revision of this standard or for additional standards and should be addressed to ASTM International Headquarters. Your comments will receive careful consideration at a meeting of the responsible technical committee, which you may attend. If you feel that your comments have not received a fair hearing you should make your views known to the ASTM Committee on Standards, at the address shown below.

This standard is copyrighted by ASTM International, 100 Barr Harbor Drive, PO Box C700, West Conshohocken, PA 19428-2959, United States. Individual reprints (single or multiple copies) of this standard may be obtained by contacting ASTM at the above address or at 610-832-9585 (phone), 610-832-9555 (fax), or service@astm.org (e-mail); or through the ASTM website (www.astm.org). Permission rights to photocopy the standard may also be secured from the Copyright Clearance Center, 222 Rosewood Drive, Danvers, MA 01923, Tel: (978) 646-2600; <http://www.copyright.com/>