



Standard Test Method for Hydrogen Chemisorption on Supported Platinum Catalysts by Volumetric Vacuum Method¹

This standard is issued under the fixed designation D3908; the number immediately following the designation indicates the year of original adoption or, in the case of revision, the year of last revision. A number in parentheses indicates the year of last reapproval. A superscript epsilon (ϵ) indicates an editorial change since the last revision or reapproval.

1. Scope

1.1 This test method covers the determination of the chemisorption of hydrogen at 298 K (25°C) on supported platinum catalysts that have been reduced in flowing hydrogen at 723 K (450°C). It incorporates a static volumetric vacuum technique at constant volume.

1.2 The test method is intended for use on unused supported platinum on alumina catalysts of loadings greater than 0.3 weight %. Data on other supports and lower platinum loadings were not tested.

1.3 *This standard does not purport to address all of the safety concerns, if any, associated with its use. It is the responsibility of the user of this standard to establish appropriate safety and health practices and determine the applicability of regulatory limitations prior to use.*

2. Referenced Documents

2.1 *ASTM Standards:*²

- D3766 Terminology Relating to Catalysts and Catalysis
- E177 Practice for Use of the Terms Precision and Bias in ASTM Test Methods
- E456 Terminology Relating to Quality and Statistics
- E691 Practice for Conducting an Interlaboratory Study to Determine the Precision of a Test Method

3. Terminology

- 3.1 *Definitions*—See Terminology D3766.
- 3.2 *Quality and Statistics*—See Terminology E456.
- 3.3 *Precision and Bias*—See Practice E177.
- 3.4 *Symbols*—The following symbols are used:

¹ This test method is under the jurisdiction of ASTM Committee D32 on Catalysts and is the direct responsibility of Subcommittee D32.01 on Physical-Chemical Properties.

Current edition approved April 1, 2015. Published June 2015. Originally approved in 1980. Last previous edition approved in 2008 as D3908 – 03 (2008). DOI: 10.1520/D3908-03R15.

² For referenced ASTM standards, visit the ASTM website, www.astm.org, or contact ASTM Customer Service at service@astm.org. For *Annual Book of ASTM Standards* volume information, refer to the standard's Document Summary page on the ASTM website.

P_c	= pressure of gas in calibrated bulb, torr
P_{mc}	= pressure of gas in calibrated bulb and manifold, torr
P_m	= pressure in manifold, torr
P_{md}	= pressure in manifold and dead space, torr
P_{m_x}	= pressure in manifold prior to expansion into sample tube for X equilibration point, torr
P_{e_x}	= equilibrium pressure after expansion for generating X equilibrium point, torr
V_c	= volume of calibrated bulb, cm ³
V_m	= volume of manifold between stopcocks 12 and 2 with only 4 and 1 open, cm ³
V_d	= volume of dead space in sample cell containing catalyst (volume between 2 and 3), cm ³
$V_{ads}(STP)_x$	= volume of gas adsorbed at STP, cm ³
$V_{ads}(STP)_{c,x}$	= cumulative volume of gas adsorbed through X , cm ³
V_S	= monolayer volume of gas adsorbed at STP, cm ³
$T_{m_{Ax}}$	= temperature representative of the manifold prior to expansion into the sample cell, K
$T_{m_{Bx}}$	= temperature representative of the entire system after equilibrium pressure (P_{e_x}) has been established, K
T_m	= temperature of manifold prior to expansion into sample cell for dead space determination, K
T_{m_D}	= temperature of entire system after equilibrium pressure has been established for dead space determination, K
T	= average manifold temperature for a given dose, K = $(T_{m_{Ax}} + T_{m_{Bx}})/2$
W_{cat}	= mass of catalyst, g
X	= weight percent of platinum
%D	= percent platinum atoms on the surface

4. Significance and Use

4.1 This test method sets forth a procedure by which duplicate catalyst samples can be compared either on an interlaboratory or intralaboratory basis. It is anticipated that catalyst producers and users will find this test method of value.

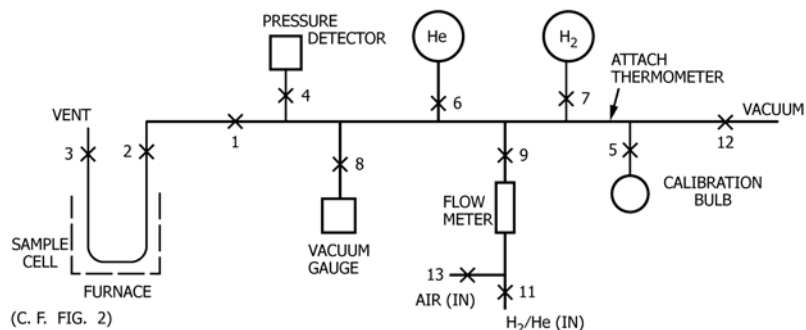

FIG. 1 Schematic: Static Vacuum System

4.2 Discrimination of the samples for which this procedure is recommended must be exercised when considering carrier (support) materials that sorb appreciable quantities of hydrogen or could cause an alteration of the state of the catalyst during pretreatment, or both, (that is, sintering or metal occlusion). These materials must be identified by the user and experimented with to determine the most significant conditions of measurement.

4.3 This test method provides a measure of the total hydrogen uptake (volume of hydrogen at STP, cm^3/g of catalyst) without specifying the nature of the hydrogen-platinum interaction. Persons interested in using hydrogen uptake data to calculate percent platinum dispersion in a specific catalyst should be aware of carrier (support) interactions, spillover effects, and other phenomena related to the hydrogen uptake capabilities of the catalyst in question.

5. Apparatus

5.1 *Gas-Handling System*, as shown in Fig. 1. The components may be either glass or metal. Commercial metal instruments are available. The following components are to be included in the glass system:

5.1.1 *Vacuum System*, capable of attaining pressures below 1 mPa (1×10^{-5} torr). The vacuum can be monitored with any suitable vacuum gauge. A diffusion pump backed by a mechanical pump must be isolated from the system by a trap held at liquid nitrogen temperature. High-vacuum stopcocks using a low-vapor pressure grease can be employed.

5.1.2 *Pressure-Measuring Device*, that operates at constant volume and that is capable of reading in the range from 0 to 66.7 kPa (0 to 500 torr) to the nearest 0.01 kPa (0.1 torr).

5.1.3 *Calibration Bulb*, whose volume has been carefully determined to within 0.1 % prior to attachment to the main manifold. Typically one fills the bulb and stopcock bore with mercury, weighs it, and calculates the volume of the bulb from the density of mercury at the temperature of the measurement. Following careful cleaning, the bulb is attached to the main manifold. One should make sure that the glass blowing is sufficiently far removed from the calibrated volume to avoid distortion.

5.1.4 *Flow-Through Cell*, that can be evacuated and that can be detached from the main manifold as, for example, see Fig. 2. This is accomplished by including a removable joint, if glass, a male cone joint, on the manifold end of the tube. (Other types of joints, that is, Swagelok with TFE-fluorocarbon

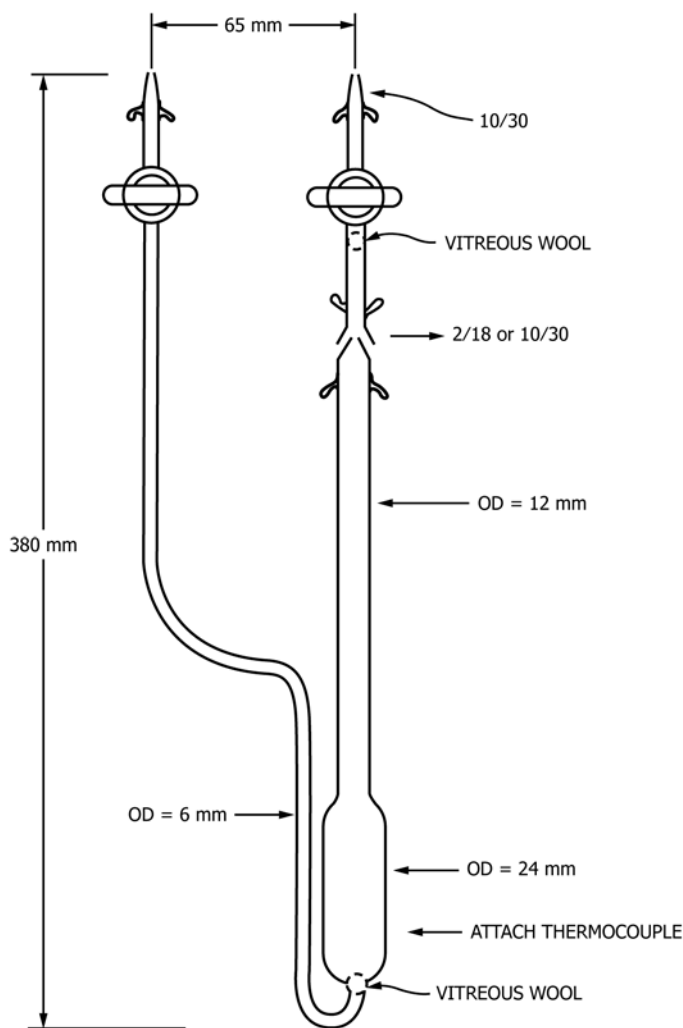

FIG. 2 Suitable Sample Cell

fittings, and so forth, are suitable.) Its mate is attached to the main manifold by a glass vacuum stopcock. A stopcock is also included on the vent side of the cell to allow for vacuum and flow-through procedures.

5.1.5 *Catalyst Sample*, secured by a quartz wool plug upstream of the catalyst and another quartz wool plug downstream (Fig. 2). The sample should be in the form of an extrudate, pellets, or powder greater than 20 mesh.

5.1.6 *Furnace*, capable of maintaining a heating rate of 5 K/min and a temperature-control mechanism capable of maintaining the furnace at temperatures in the range from 673 to 773 ± 10 K (400 to 500°C).

5.1.7 *Thermometer or Thermocouple*, to monitor the furnace temperature to within ± 5 K and two thermometers to register the temperature of the manifold system and sample cell during uptake determination to the nearest ± 0.1 K.

5.1.8 *Balance*, measuring to the nearest 1 mg (± 0.001 g).

5.1.9 *Flowmeter*, for hydrogen capable of measuring a flow rate of between 10 and 25 ± 3 cm³ (STP) gas per minute.

5.2 *Gas Purification Facilities*, for helium and hydrogen.

6. Reagents

6.1 *High-Purity Helium*, purified by passing through a trap containing activated (**Note 1**) molecular sieve of the A type or 13X type, maintained at liquid nitrogen temperature.

NOTE 1—Activation as suggested by manufacturer.

6.2 *High-Purity Hydrogen*, purified by passing first through an oxygen removal catalyst or palladium thimble and then through a trap containing activated molecular sieve of the A type or 13X type maintained at liquid nitrogen temperature.

6.3 *High-Purity Cylinder Air*, purified by passing through a trap containing activated molecular sieve of the A series.

7. Safety Hazards

7.1 Follow the usual precautions associated with handling hydrogen gas. Adequately vent the hydrogen flow at the roughing pump discharge and vent the sample (stopcock 3). A flash arresting check valve and pressure relief valves or safety manometers should be incorporated into the design of the apparatus.

7.2 Adequately tape or otherwise shield glass reservoirs to avoid unrestricted explosion in the event of an over-fill and to avoid flying glass in the event of an implosion during evacuation.

7.3 Eye protection is essential when operating the vacuum system.

7.4 Avoid accidental formation of mixtures of hydrogen and air at all times.

8. Volume Calibrations

8.1 The reliability of any gas adsorption measurement is naturally dependent on the accuracy with which the system volume is known. It is therefore essential that the manifold volume be frequently determined very carefully to ensure accurate hydrogen uptake data. Recalibrate the system if any changes are made to the system. The volume of the standard bulb shown in the diagram was previously measured (see 5.1.3). Expansion of a known pressure of gas into the evacuated system will allow a determination of system volume. The following steps are recommended for system calibration. Refer to **Fig. 1** for location of numbered stopcocks.

8.1.1 Evacuate main manifold by opening stopcocks 1, 4, 5, 8, and 12 with all others closed.

8.1.2 Close stopcocks 12 and 8 and introduce helium to the system by opening 6. After establishment of a pressure of less than one atmosphere, close 6. Record the pressure (P_c).

8.1.3 Close stopcock 5, open 12, and evacuate.

8.1.4 Close stopcock 12 and expand gas in the calibration bulb by opening 5. Record final pressure (P_{mc}).

8.1.5 Repeat Steps 8.1.2 – 8.1.4 ten times and average to obtain the final pressure (P_{mc}).

9. Charging Sample

9.1 The amount of sample to be charged is determined by the expected hydrogen uptake and the maximum capacity of the sample cell. Experience and the platinum loading will dictate the optimum amount, but a minimum of 1 g is considered essential. This mass need not be precisely known since a final weighing will be made after determination of the hydrogen uptake. It may, however, be useful for the determination of volatile or combustible matter present, or both, on the unused catalyst.

9.1.1 Plugs of quartz wool are to be charged to the cell as shown in **Fig. 2**. Weigh the cell and wool plug(s).

9.1.2 Charge at least 1 g of catalyst to the cell.

9.1.3 Connect the cell to the main manifold at stopcock 2 and vent.

9.1.4 Secure the thermocouple to the glass along the outside of the center of the catalyst bed (**Fig. 2**).

10. Air Calcination

10.1 To ensure removal of adsorbed hydrocarbons from the catalyst surface due to ambient contamination a calcination in purified air is recommended.

10.1.1 Close all stopcocks except 3, 2, and 1. Establish a flow of air between 10 and 25 cm³/g of catalyst per minute by opening stopcocks 13 and 9.

10.1.2 Commence heating of the catalyst to 723 K (450°C) at a rate not to exceed 10°C/min. Hold at 723 K (450°C) for 1 h.

10.1.3 Cool to 673 to 698 K (400 to 425°C).

10.1.4 Close stopcocks 3 and 13. Evacuate by opening 12 cautiously to avoid disturbance of the sample. Open 8. Continue to evacuate until a vacuum of about 1 mPa (10^{-5} torr) is established. Close 8.

10.1.5 Remove furnace and cool cell to room temperature. Close stopcock 12.

11. Sample Reduction

11.1 Open stopcocks 11, 9, 4, 2, and 1 and allow the hydrogen pressure to reach atmospheric. Open 3 and adjust the hydrogen flow to between 10 and 25 cm³/g of catalyst per minute. Continue purge for 15 to 30 min or until reasonably confident that the system is essentially free of air.

11.1.1 Replace the furnace and commence heating the sample cell at a rate not exceeding 10°C/min.

11.1.2 Hold at 723 K (450°C) for 1 to 2 h.

11.1.3 Cool to between 673 and 698 K (400 and 425°C).

11.1.4 Close stopcock 3 and then immediately 9, then 2. Open 12 and 8 and evacuate. After a good vacuum (about 1 mPa (10^{-5} torr)) is reached, open 2 slowly to avoid disturbance of the sample.

11.1.5 Continue evacuation until the vacuum gauge reads about 5 mPa (5×10^{-5} torr) or less. If this requires more than 1 h, a vacuum leak may be suspected. Repair it and repeat from 11.1. Remove the furnace, cool the sample rapidly to room temperature, and then close stopcock 2.

11.1.6 After the sample cell is at room temperature close stopcocks 8 and 12.

12. Procedure: Hydrogen Up-Take

12.1 Gradually open stopcock 7 and expand hydrogen into the manifold up to stopcock 2. Experience will dictate a suitable pressure; about 6.67 kPa (50 torr) is usually acceptable. Close 7. Record P_{m_j} . Record $T_{m_{A1}}$, the temperature representative of the manifold prior to expansion into the sample cell.

12.1.1 After thermostating the sample to a desired temperature ~ 295 to 298 K (~ 20 to 25 C) water in a Dewar flask is suitable), open stopcock 2 and expand hydrogen into the sample cell. Note the temperature of the sample, T .

12.1.2 Follow an approach to equilibrium by noting the change in pressure with time. Record the equilibration pressure (P_{e_1}). Typical equilibration times will be 30 to 60 min. Record $T_{m_{B1}}$, the temperature representative of the entire system after pressure equilibrium has been established.

12.1.3 After equilibration, close stopcock 2 and add additional hydrogen to the manifold by carefully opening 7. Record the pressure (P_{m_2}). Record $T_{m_{A2}}$.

12.1.4 Repeat procedure 11.1 – 11.1.4 through a minimum of three times approximately evenly spaced between 13.3 kPa (100 torr) and 40 kPa (300 torr). Record equilibration pressures to P_{e_x} or to P_{e_x} where $x > 3$. Record $T_{m_{Ax}}$ and $T_{m_{Bx}}$ for each dosing.

13. Dead Space

13.1 Open stopcocks 12 and 8 and evacuate cell and manifold to 1.3×10^{-3} Pa (10^{-5} torr).

13.1.1 Close stopcocks 2, 8, and 12 and gradually bleed helium to a pressure of about 53.2 to 66.5 kPa (400 to 500 torr) into manifold by gently opening 6. Close 6. Record the pressure (P_m). Record the temperature T_m .

13.1.2 Open stopcock 2 and expand the gas from manifold into the sample cell. Record the pressure (P_{md}). Record the T_{m_d} .

13.1.3 Repeat 13.1 – 13.1.2 at least three times.

13.1.4 Close stopcock 2 and gradually open 3.

13.1.5 Remove the sample cell from the system.

13.1.6 Weigh the catalyst sample and cell. Subtract the tare mass from 9.1.1 to obtain the sample mass, W_{cat} .

14. Calculation for Manifold Calibration

$$V_m = V_c \left[\frac{P_c}{P_{mc}} - 1 \right] \quad (1)$$

NOTE 2—It is assumed that this measurement is taken in a time element short enough that the temperature of the system is constant.

15. Calculation for Dead Space Volume

$$V_d = V_m \left[\frac{P_m}{P_{md}} - 1 \right] \quad (2)$$

NOTE 3—It is assumed that this measurement is taken in a time element

short enough that the temperature of the system is constant.

16. Calculation for Hydrogen Chemisorption (Adsorption Method)

DOSE 1

$$V_{ads}(STP)_1 = \left[V_m \left(\frac{P_{m_1}/T_{m_{A1}}}{P_{e_1}/T_{m_{B1}}} - 1 \right) - V_d \right] \left(\frac{273}{T} \right) \left(\frac{P_{e_1}}{760} \right) \quad (3)$$

DOSE 2

$$V_{ads}(STP)_2 = \left[V_m \left(\frac{P_{m_2}/T_{m_{A2}}}{P_{e_2}/T_{m_{B2}}} - 1 \right) + V_d \left(\frac{P_{e_1}/T_{m_{B1}}}{P_{e_2}/T_{m_{B2}}} - 1 \right) \right] \left(\frac{273}{T} \right) \left(\frac{P_{e_2}}{760} \right) \quad (4)$$

DOSE 3

$$V_{ads}(STP)_3 = \left[V_m \left(\frac{P_{m_3}/T_{m_{A3}}}{P_{e_3}/T_{m_{B3}}} - 1 \right) + V_d \left(\frac{P_{e_2}/T_{m_{B2}}}{P_{e_3}/T_{m_{B3}}} - 1 \right) \right] \left(\frac{273}{T} \right) \left(\frac{P_{e_3}}{760} \right) \quad (5)$$

DOSE X

$$V_{ads}(STP)_x = \left[V_m \left(\frac{P_{m_x}/T_{m_{Ax}}}{P_{e_x}/T_{m_{Bx}}} - 1 \right) + V_d \left(\frac{P_{e_{x-1}}/T_{m_{B_{x-1}}}}{P_{e_x}/T_{m_{Bx}}} - 1 \right) \right] \left(\frac{273}{T} \right) \left(\frac{P_{e_x}}{760} \right) \quad (6)$$

$$V_{ads}(STP)_{cx} = \sum V_{ads}(STP)_x$$

NOTE 4—If, during the course of the measurements the manifold temperature remains constant within $\pm 2^\circ\text{C}$, one could assume $T_{m_{Ax}} \cong T_{m_{Bx}} = T$ which simplifies Eq 6*.

17. Precision and Bias

17.1 *Test Program*—An interlaboratory study was conducted in which the named property was measured on one material in five separate laboratories. Practice E691, modified for nonuniform data sets, was followed for the data reduction.

17.2 *Precision*—Pairs of test results obtained by a procedure similar to that described in the study are expected to differ in value by less than 2.772 S, where 2.772 S is the 95 % probability limit on the difference between the test results and S is the appropriate estimate of standard deviation.

Test Result (Consensus)	95 % Repeatability Limit	95 % Reproducibility
	(Within Laboratory)	Limit (Between Laboratory)
0.122 cm ³ /g	0.008 (6.8 %)	0.011 (9.1 %)

17.3 *Bias*—This test method described is without known bias.

18. Construction of Isotherm

$$P_{e_x} \text{ versus } \frac{V_{ads}(STP)_{cx}}{W_{cat}} \quad (7)$$

19. Calculation of Monolayer Volume and Dispersion

19.1 Extrapolate the linear portion of the isotherm between 100 and 300 torr to zero pressure. The Y intercept of the extrapolated line is the monolayer volume, V_S .

19.2 Calculate the percent dispersion, %D, using the following equation:

$$\%D = 174 \times V_s / X \quad (8)$$

20. Keywords

20.1 chemisorption; hydrogen chemisorption; platinum catalysts; volumetric method

ASTM International takes no position respecting the validity of any patent rights asserted in connection with any item mentioned in this standard. Users of this standard are expressly advised that determination of the validity of any such patent rights, and the risk of infringement of such rights, are entirely their own responsibility.

This standard is subject to revision at any time by the responsible technical committee and must be reviewed every five years and if not revised, either reapproved or withdrawn. Your comments are invited either for revision of this standard or for additional standards and should be addressed to ASTM International Headquarters. Your comments will receive careful consideration at a meeting of the responsible technical committee, which you may attend. If you feel that your comments have not received a fair hearing you should make your views known to the ASTM Committee on Standards, at the address shown below.

This standard is copyrighted by ASTM International, 100 Barr Harbor Drive, PO Box C700, West Conshohocken, PA 19428-2959, United States. Individual reprints (single or multiple copies) of this standard may be obtained by contacting ASTM at the above address or at 610-832-9585 (phone), 610-832-9555 (fax), or service@astm.org (e-mail); or through the ASTM website (www.astm.org). Permission rights to photocopy the standard may also be secured from the Copyright Clearance Center, 222 Rosewood Drive, Danvers, MA 01923, Tel: (978) 646-2600; <http://www.copyright.com/>