



Standard Test Method for Sampling Amphibole Asbestos¹

This standard is issued under the fixed designation D 3879; the number immediately following the designation indicates the year of original adoption or, in the case of revision, the year of last revision. A number in parentheses indicates the year of last reapproval. A superscript epsilon (ε) indicates an editorial change since the last revision or reapproval.

^{ε1} NOTE—Asbestos warning was moved from 7.1.1 to 1.5 in September 2004.

1. Scope

1.1 This test method describes the procedure for taking a composite sample or a master composite sample (at the mine, at the factory, or from a consignment) from a lot of commercial milled amphibole fibers, conditioning the sample, and reducing it in quantity so as to provide a series of relatively small test specimens of loose asbestos fiber, each of which may be regarded as representative of the lot. (See Appendix X1 for sampling strategy.)

1.2 This test method is suitable for taking test specimens of amphibole asbestos for the following test methods: C 1119, C 1120, C 1121, C 1122, C 1123, C 1124, C 1125, C 1162, D 1118, D 2589, D 2752, D 2947, D 2985, D 2987, D 3639, D 3752, and D 3880.

1.3 For sampling chrysotile asbestos, use Method D 2590.

1.4 The values stated in SI units are to be regarded as the standard. The values given in parentheses are for information only.

1.5 **Warning**—Breathing of asbestos dust is hazardous. Asbestos and asbestos products present demonstrated health risks for users and for those with whom they come into contact. In addition to other precautions, when working with asbestos-cement products, minimize the dust that results. For information on the safe use of chrysotile asbestos, refer to “Safe Use of Chrysotile Asbestos: A Manual on Preventive and Control Measures.”²

1.6 *This standard does not purport to address all of the safety concerns, if any, associated with its use. It is the responsibility of the user of this standard to establish appropriate safety and health practices and determine the applicability of regulatory limitations prior to use.* See 1.5 for a specific hazard warning.

2. Referenced Documents

2.1 ASTM Standards:³

- C 1119 Test Method for Vacuum Drainage of Asbestos-Cement Mixes
- C 1120 Test Method for Wash Test of Asbestos
- C 1121 Test Method for Turner and Newall (T and N) Wet-Length Classification of Asbestos
- C 1122 Test Method for Wet Volume of Asbestos
- C 1123 Test Method for Compressibility and Recovery of Asbestos
- C 1124 Test Method for Kerosene Retention of Asbestos
- C 1125 Test Method for Penetration Index of Asbestos
- C 1162 Test Method for Loose Density of Asbestos
- D 1118 Test Method for Magnetic Rating of Asbestos Fiber and Products
- D 2589 Test Method for McNett Wet Classification of Asbestos Fibers
- D 2590 Test Method of Sampling Chrysotile Asbestos
- D 2752 Test Methods for Air Permeability of Asbestos Fibers
- D 2946 Terminology Relating to Asbestos and Asbestos-Cement Products
- D 2947 Test Method for Screen Analysis of Asbestos Fibers
- D 2985 Test Method for Color of Asbestos
- D 2987 Test Method for Moisture Content of Asbestos Fiber
- D 3639 Test Method for Classification of Asbestos Fibers by Quebec Standard Test
- D 3752 Test Method for Strength Imparted by Asbestos to a Cement Matrix
- D 3880 Test Method for Asbestos Strength Units

3. Terminology

3.1 Definitions of Terms Specific to This Standard:

¹ This test method is under the jurisdiction of ASTM Committee C17 on Fiber-Reinforced Cement Products and is the direct responsibility of Subcommittee C17.03 on Asbestos-Cement Sheet Products and Accessories.

Current edition approved June 1, 2004. Published August 2004. Originally approved in 1980. Last previous edition approved in 1999 as D 3879 – 91 (1999).

² Available from The Asbestos Institute, http://www.chrysotile.com/en/sr_use/manual.htm.

³ For referenced ASTM standards, visit the ASTM website, www.astm.org, or contact ASTM Customer Service at service@astm.org. For *Annual Book of ASTM Standards* volume information, refer to the standard's Document Summary page on the ASTM website.

3.1.1 *accessible bag*—a bag (in a pile of bags of asbestos fiber) of which at least one side or one end is fully exposed.

3.1.2 *accessible surface*—in a pile of bags of asbestos fiber, a side (of the pile) in which all the bags are accessible bags.

3.1.3 *amphibole asbestos, n*—asbestiform amphibole silicate minerals including the orthorhombic anthophyllite series and the monoclinic cummingtonite [grunerite asbestos (amosite)] series, the tremolite-actinolite series, and the alkali amphibole [riebeckite asbestos (crocidolite)] series among others. The amphiboles contain essential (OH) groups in their structure, and the Si:O ratio is 4:11. A considerable amount of elemental substitution can take place in these varieties of asbestos. The crystal structures are composed of strips or ribbons of linked polyhedra that join to form fibrils. The individual strips are made up from three components; these are two double chains of linked (Si, Al) O₄ tetrahedra and a strip of linked MgO₆, FeO₆ or AlO₆ octahedra (see Tables 1 and Tables 2 in Terminology D 2946).

3.1.4 *bag*—any quantity of asbestos fiber corresponding to one particular grade that is packed in a suitable container.

NOTE 1—In the asbestos industry the typical quantity contained in a bag is 45 kg (100 lb approximately).

3.1.5 *composite sample*—a set of unit samples of asbestos fiber (drawn systematically or at random) taken from a lot, comprising not less than 2 and not more than 200 bags, for use in the laboratory as a test sample, that is, as a source of test specimens.

3.1.6 *conditioning*—the process by which the fiber is put into a consistent condition to be tested.

3.1.7 *contaminants*—any foreign matter (other than associated minerals and fines) in a sample of asbestos fiber.

3.1.8 *grade*—asbestos fiber that has the same chemical, physical, and mechanical properties and that is designated by a particular code corresponding to any given specification.

3.1.9 *handful, n—in sampling*, as much fiber as the hand can contain.

3.1.10 *lot*—not less than 2 and not more than 2000 bags of asbestos fiber of the same type and grade offered at any one time for delivery or testing.

3.1.11 *master composite sample*—not less than 2 and not more than 10 composite samples so combined and reduced as to form a test sample that represents a lot that consists of more than 200 bags but not more than 2000 bags.

3.1.12 *milled asbestos, n*—all grades of asbestos that are recovered as a result of mechanical comminution and screen classification or air classification of asbestos ore.

3.1.13 *random composite sample*—a composite sample in which each individual bag in the lot that is being sampled has an equal chance of being included in the composite sample.

3.1.14 *systematic composite sample*—a composite sample that is obtained by taking every *n*th bag in the lot being sampled.

3.1.15 *systematic sample, n—in asbestos*, the sample is systematic if it is formed of every *n*th bag of the lot to be examined.

3.1.16 *test specimen*—the specific portion of a test sample upon which a test is to be performed, and that is obtained by

systematically reducing the size of the sample until a representative fiber specimen of the required mass is obtained.

3.1.17 *unit sample*—a sample drawn from one bag.

3.2 *Definitions*—Definitions of terms relating to asbestos fiber are given in Terminology D 2946.

4. Summary of Test Method

4.1 Lots consisting of more than 200 bags are divided into sublots comprising about 200 bags. From each subplot a composite sample is taken consisting of one handful from each of 20 bags selected either systematically or at random.

4.2 Each composite sample is passed through a fluffer (conditioner) to disperse lumps before combining and mixing with the others. The combined sample is then reduced by coning and quartering.

4.3 Test specimens are drawn from the sample by coning and quartering. Specimens for Test Method D 3639 are further pressed and repassed through the conditioner.

5. Significance and Use

5.1 Sampling and conditioning are equally as important as testing. The reliability of the test results depends primarily upon how well the specimens tested represent the true character and condition of the lot of asbestos fiber. Much care and effort are required to be sure that all the sampling operations are systematic or at random, and are representative. Failure to provide a test specimen that accurately represents the lot from which it is drawn will produce misleading test results regardless of the accuracy and the precision of the test method.

6. Apparatus

6.1 *Fiber Conditioner and Fiber Press*^{4,5}—Refer to Fig. 1 and Fig. 2.

6.2 *Sampling Ring and Cross*—The ring shall be of 3-mm-thick hoop iron and shall have a diameter of approximately 600 mm and a height of about 50 mm. The cross shall be of a suitable metal, plywood, or plastic material, and the arms of the cross shall be of equal length and shall be 75 mm high and 3 mm thick. The length of the arms shall be such that the cross fits loosely in the ring. All surfaces of the ring and of the cross shall have a smooth finish.

6.3 *Fiber Knife*, of a plywood or plastic material, rectangular in shape, and approximately 300 mm long, 75 mm wide, and 3 mm thick.

7. Sampling

7.1 *Obtaining Composite Samples and Master Composite Samples:*

7.1.1 If a lot consists of more than 200 bags, divide it into sublots each comprising about 200 bags. From each lot comprising not less than 20 and not more than 200 bags, or each sub-lot, as relevant, take (preferably as in 7.1.2, or, when

⁴ Information on the fiber conditioner and fiber press is obtainable from the South African Bureau of Standards, Private bag X191, Pretoria 0001, Republic of South Africa.

⁵ Detailed drawings of the fiber conditioner are available from ASTM International Headquarters at a nominal price. Request Adjunct No. 12-425900-00 to Test Method D 2590.

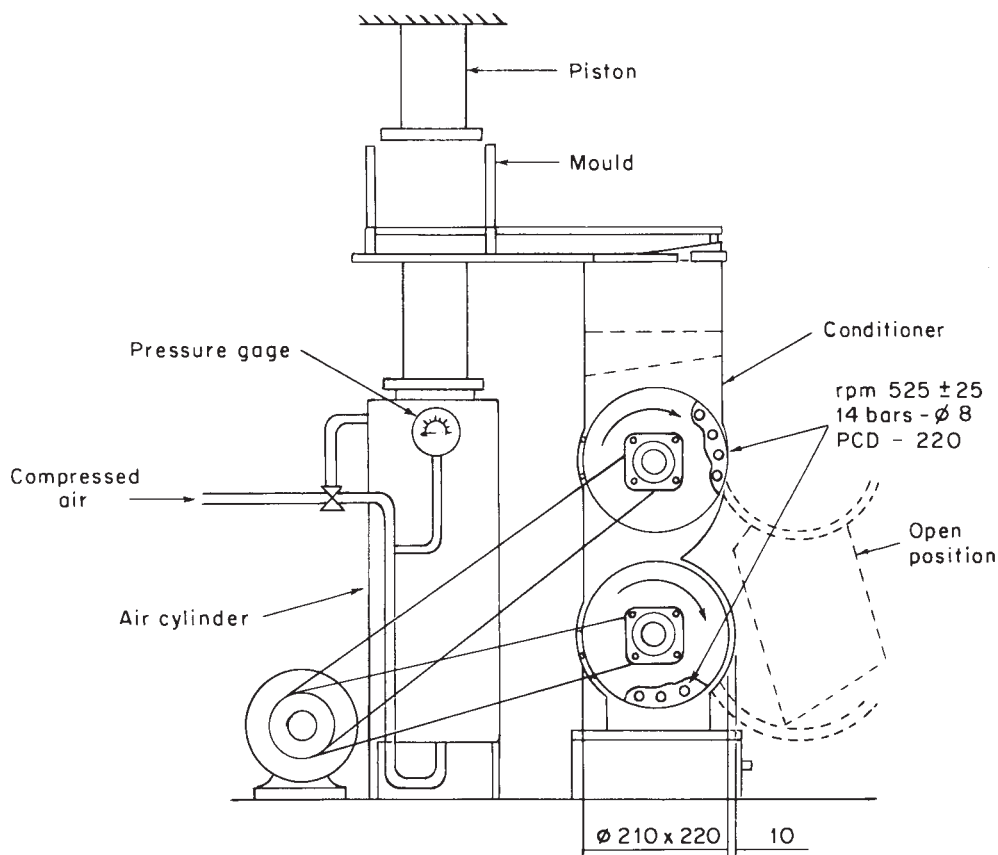

Dimensions in millimetres
FIG. 1 Fiber Conditioner and Fiber Press

applicable, 7.1.3) a composite sample of mass approximately 2.5 kg or, if the need for a larger sample is foreseen, of such larger mass as is required. (**Warning**—see 1.5.)

NOTE 2—A larger composite sample may be obtained by increasing the size of the handfuls of fiber taken from each bag.

NOTE 3—If a lot consists of less than 20 bags, the relevant procedure given in Appendix X1 should be used.

7.1.2 Obtain the composite sample by taking a handful (of mass approximately 125 g) from each of 20 bags chosen as in 7.1.2.1 or, if practicable, as in 7.1.2.2, and combine the handfuls. Take the handfuls from different positions in the bags, avoiding taking the handfuls from the top surfaces of the fiber in the bags.

7.1.2.1 To obtain a systematic sample, designate the number of bags in the lot as N and take a handful from every $N/20$ th bag in the lot (see Appendix X1 for the procedure recommended in cases when $N/20$ is not a whole number).

7.1.2.2 To obtain a random sample, choose the 20 bags at random, preferably using a table of random numbers (see X1.2).

7.1.3 When not all the bags are accessible, and if mutually agreed upon between the parties concerned, obtain the composite sample as in 7.1.3.1 or 7.1.3.2, as relevant.

7.1.3.1 If the accessible surface of the lot or subplot, as relevant (see 7.1.1), comprises 20 bags or more, take a handful of fiber from one bag in each $\frac{1}{20}$ portion of the surface.

7.1.3.2 If the accessible surface of the lot or subplot, as relevant (see 7.1.1), comprises less than 20 bags, take approximately equal portions from each bag.

7.1.4 If the use of a master composite sample has been agreed upon between the parties concerned, prepare this sample as follows:

7.1.4.1 Pass each composite sample through the fiber conditioner without using the press, and then combine and mix the composite samples thoroughly, taking care to break down and distribute any lumps of mass greater than 12.5 g. Exercise care to not break up any fiber agglomerates consisting of fibers in close-packed parallel orientation.

7.1.4.2 Spread the fiber on a smooth, even surface so as to form a flat circular bed of uniform thickness. Divide the fiber bed into four equal quadrants. Remove the fiber from two diametrically opposite quadrants (taking care that all the material in these quadrants is removed) and blend the remaining fiber.

7.1.4.3 Repeat the procedure given in 7.1.4.2 until a master composite sample of mass approximately 2.5 kg is obtained.

NOTE 4—Alternatively, the combined composite samples may be reduced to approximately 2.5 kg by means of a riffle or a sample splitter.

7.1.5 Record the type of sampling procedure used and details of the sampling.

7.2 *Storage of Samples*—Place each test sample (composite or master composite) in a separate closed container and store

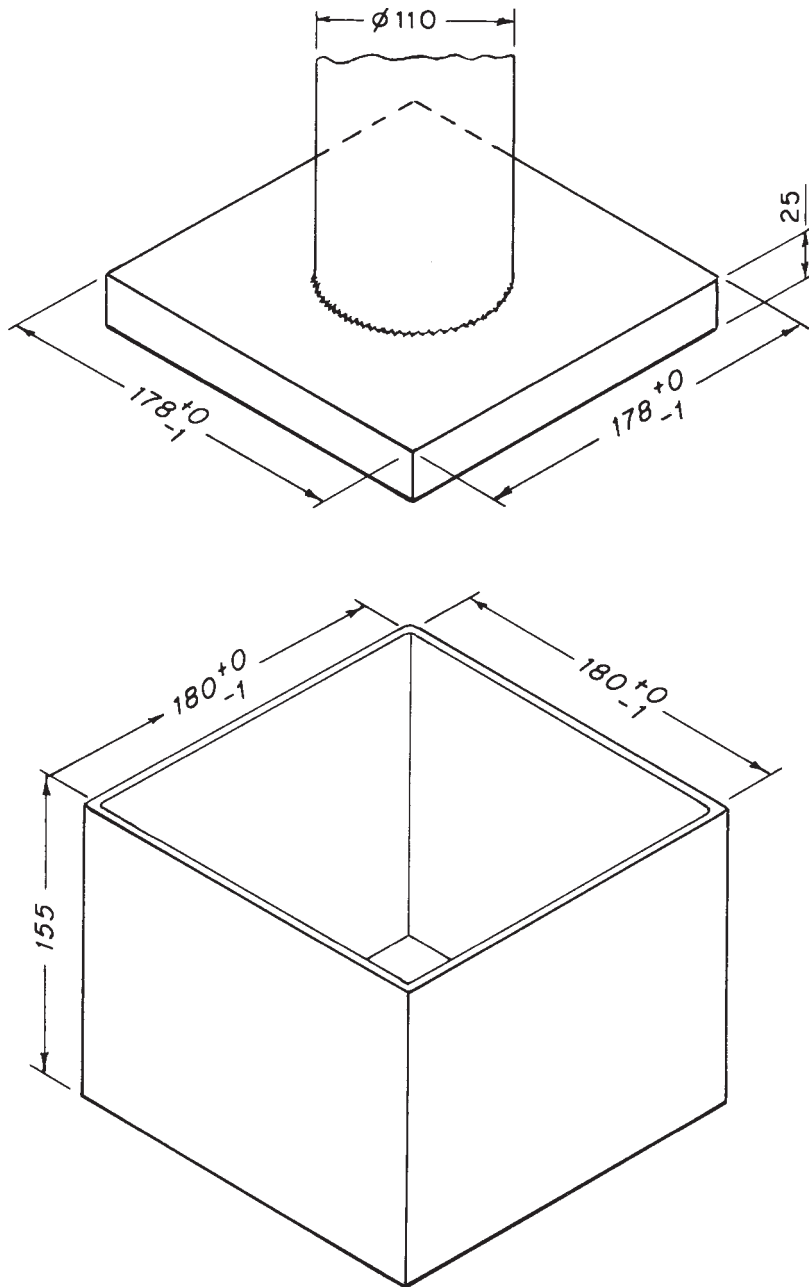

Dimensions in millimetres

FIG. 2 Piston and Mold

under cover until the test specimens are prepared. In the case of samples intended for moisture determinations use moisture-proof containers and protect them from temperature changes.

7.3 Conditioning and Mixing—Before taking test specimens from it, (except specimens for moisture determinations), allow each test sample to reach equilibrium with laboratory temperature and humidity, and ensure that the moisture content of fibers does not exceed 1 % in accordance with Test Method D 2987. Condition the test sample in the laboratory fiber conditioner. If a two stage fiber conditioner is used, pass portions of the composite sample through the conditioner until the whole test sample has been conditioned. If a single-stage conditioner is used, pass the whole test sample twice through the conditioner. Mix the test sample thoroughly.

NOTE 5—Do not pass the test sample through the mold press.

NOTE 6—Put the test specimen for Test Method D 3639 (see C1 and C3 of Fig. 3) into the fiber mold and compress for 1 min at a pressure of 19.4 kPa (pressure gage reading 6 ± 0.5 bar). Pass it through the fiber conditioner two more times (for single stage conditioners) or once for two stage conditioners.

8. Test Specimens

8.1 Use the sampling scheme given in Fig. 3 for the preparation of the test specimens. Carry out the preparation of the test specimens as follows:

8.1.1 Spread the test sample (see 7.1.1 and 7.1.2) on a smooth, clean surface so that it forms a flat even bed with a circular shape approximately 10 cm thick. Remove and record any contaminants present.

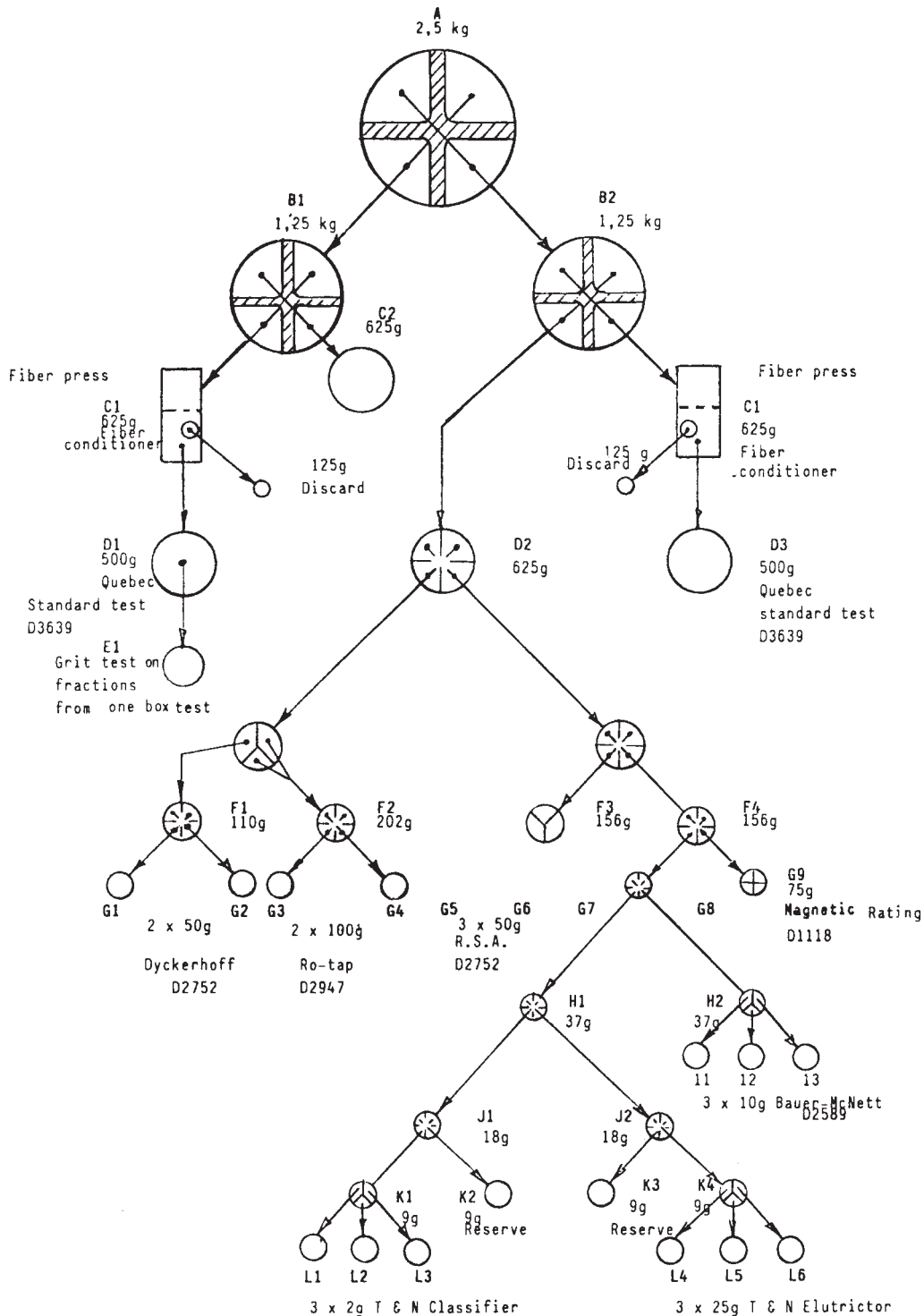

FIG. 3 Sample Scheme

8.1.2 Using the fiber knife, divide the fiber bed into four equal quadrants (see Stage A in Fig. 3). Combine the diametrically opposite quarters.

8.1.3 Place one of these combined portions in the sampling ring, level the fiber and introduce the cross so that the bed of fiber is divided into four equal quarters, and continue the process of quartering using the sampling ring and cross up to Stage F.

8.1.4 After each quartering process, blend the diametrically opposite quarters by gentle mixing with the finger tips, taking care to avoid raising dust or changing the physical structure of the fibers.

8.1.5 At each stage of quartering, progressively reduce the size of any small lumps of fiber by hand, but exercise care that a minimum of opening treatment is given to the fiber (see 7.1.4.1).

8.1.6 After Stage F, again spread the fiber, quarter the fiber using the fiber knife, and combine opposite quarters. Do not use the sampling ring and cross.

8.1.7 When the fiber mass is reduced to the approximate sample mass required for a specific test, carefully adjust the mass using tweezers to remove or add fiber until the correct mass is obtained. When necessary, carry out the adjustment carefully and ensure that the fiber removed or added to the test specimen is similar to the specimen as a whole and does not alter its representative character.

NOTE 7—The sampling scheme given in Fig. 3 represents the technique to be used for a 2.5-kg test sample to obtain test specimens required for the testing of both spinning and shingle grades. In the case of some fibers not all the test specimens are required, but the procedure should be maintained, and those portions not required may be used for other tests,

retained for future reference, or discarded. The letters A to K in Fig. 3 refer to the progressive stages of reduction of the mass of fiber by mixing and quartering.

9. Precision and Bias

9.1 Precision, or sampling error, cannot be determined since this depends mainly upon the homogeneity of the material being sampled, which varies significantly from one type of amphibole to another, and even from grade to grade of a given type.

9.2 Bias cannot be determined for lack of a known standard of comparison.

10. Keywords

10.1 amphibole asbestos; asbestos; sample; sampling; test specimen

APPENDIX

(Nonmandatory Information)

X1. SAMPLING STRATEGY

X1.1 Systematic Sampling

X1.1.1 The principle of systematic sampling requires that 20 handfuls are taken at approximately even intervals throughout the entire lot.

X1.1.2 For example, if the lot comprises 100 bags, then a handful must be taken from every 5th bag ($N/20 = 100/20 = 5$); that is, the 20 handfuls would be taken one from each of the 20 bags distributed evenly throughout the entire lot. Similarly, a handful would be taken from every third bag when sampling a lot comprising 60 bags.

X1.1.3 If the lot comprises only 10 bags, then two handfuls must be taken from each bag, that is, a handful from each half bag ($N/20 = 10/20 = 1/2$). Similarly, four handfuls would be taken from each bag in a lot of five, ten handfuls from each bag in a lot of two, and so on.

X1.1.4 With lots comprising an odd number of bags, the above principles should be followed as far as possible, where necessary supported by random sampling to complete the twenty handfuls; for example, to sample a lot size 15, take one handful from each bag and a further five handfuls at random from the entire lot; or to sample a lot size 7, take two handfuls from each bag and a further six handfuls at random from the entire lot.

X1.1.5 Lots comprising an odd number of bags greater than 20 should be sampled on the assumption that the true lot size N has been reduced or increased to an assumed lot size n where $n/20$ equals the nearest whole number; for example, to sample a lot size $N = 167$, reduce to $n = 160$ by taking one handful from every 8th bag; or to sample a lot size $N = 56$, increase to $n = 60$ by taking one handful from every third bag. However, in the latter case the lot would be able to yield only 18 handfuls, and the remaining two handfuls must be taken at random within the entire lot.

X1.2 Random Sampling

X1.2.1 The objective of random sampling is to try to ensure that any part of the lot has an equal chance of being included in the composite sample; that is, handfuls should be taken at random from any bag included in the lot. The choice must not be influenced by ease of access, appearance, or location and it is therefore important that the entire lot is presented with reasonable access to the inspection.

X1.2.2 Although there can be no assurance that the quality of any particular composite sample will be the same as that of the lot from which it is drawn, it can be expected that in the long run the average quality of samples drawn at random will be approximately the same as the average quality of the parent lots.

X1.2.3 In practice, random samples are often chosen intuitively by an inspector attempting to sample a realistic cross section of the lot. However, as this process is to some extent subject to human error, it is advisable to select the samples with the aid of tables of random numbers. These are lists of numbers written down in random order and are used as follows: If we wished to draw 20 handfuls at random from a lot of 100 bags, we would first allocate to each bag a number from 1 to 100. Then reading down or across a column of random numbers, the first two digits would in each case nominate a bag to be included in the composite sample; that is, if from the table of random numbers we read 5754, 7313, 0354, etc., we would include bags numbered 57, 73, and 3, etc., until we had randomly chosen 20 bags from which to take a handful of fiber to form our composite sample.

 **D 3879 – 91 (2004)^{e1}**

ASTM International takes no position respecting the validity of any patent rights asserted in connection with any item mentioned in this standard. Users of this standard are expressly advised that determination of the validity of any such patent rights, and the risk of infringement of such rights, are entirely their own responsibility.

This standard is subject to revision at any time by the responsible technical committee and must be reviewed every five years and if not revised, either reapproved or withdrawn. Your comments are invited either for revision of this standard or for additional standards and should be addressed to ASTM International Headquarters. Your comments will receive careful consideration at a meeting of the responsible technical committee, which you may attend. If you feel that your comments have not received a fair hearing you should make your views known to the ASTM Committee on Standards, at the address shown below.

This standard is copyrighted by ASTM International, 100 Barr Harbor Drive, PO Box C700, West Conshohocken, PA 19428-2959, United States. Individual reprints (single or multiple copies) of this standard may be obtained by contacting ASTM at the above address or at 610-832-9585 (phone), 610-832-9555 (fax), or service@astm.org (e-mail); or through the ASTM website (www.astm.org).