



Standard Test Method for Strength Properties of Adhesives in Cleavage Peel by Tension Loading (Engineering Plastics-to-Engineering Plastics)¹

This standard is issued under the fixed designation D3807; the number immediately following the designation indicates the year of original adoption or, in the case of revision, the year of last revision. A number in parentheses indicates the year of last reapproval. A superscript epsilon (ϵ) indicates an editorial change since the last revision or reapproval.

1. Scope

1.1 This test method covers the determination of the comparative cleavage/peel strengths of adhesives for bonding engineering plastics when tested on a standard specimen and under specific conditions of preparation and testing.

1.2 The values stated in SI units are to be regarded as the standard. The values given in parentheses are for information only.

1.3 *This standard does not purport to address all of the safety concerns, if any, associated with its use. It is the responsibility of the user of this standard to establish appropriate safety and health practices and determine the applicability of regulatory limitations prior to use.*

2. Referenced Documents

- 2.1 *ASTM Standards*:²
[D907 Terminology of Adhesives](#)

3. Terminology

3.1 *Definitions*—Many of the terms used in this test method are defined in Terminology [D907](#).

3.2 *Definitions of Terms Specific to This Standard*:

3.2.1 *semirigid adherend, n*—an adherend that has dimensions and physical properties that permit bending at designated test temperature through any angle up to 30° without breaking or cracking.

4. Significance and Use

4.1 This test method determines strength properties of adhesives in cleavage peel by tension loading. It allows the

¹ This test method is under the jurisdiction of ASTM Committee [D14](#) on Adhesives and is the direct responsibility of Subcommittee [D14.40](#) on Adhesives for Plastics.

Current edition approved May 1, 2012. Published May 2012. Originally approved in 1979. Last previous edition approved in 2004 as D3807 – 98 (2004). DOI: 10.1520/D3807-98R12.

² For referenced ASTM standards, visit the ASTM website, www.astm.org, or contact ASTM Customer Service at service@astm.org. For *Annual Book of ASTM Standards* volume information, refer to the standard's Document Summary page on the ASTM website.

comparative testing of cleavage/peel strengths of bonded engineering thermoplastic adherends.

4.2 Cleavage/peel forces are common in bonded assemblies. This test method gives information as to the performance of substrate/adhesive combinations under cleavage/peel forces.

5. Apparatus

5.1 *Tension Testing Machine*, capable of applying a tensile load having the following prescribed conditions:

5.1.1 Select the machine and loading range so that the maximum load on the specimen falls between 15 and 85 % of the upper limit of the loading range.

5.1.2 Maintain the rate of movement between heads to be essentially constant under fluctuating loads.

NOTE 1—It is difficult to meet this requirement when loads are measured with a spring-type or pendulum-type weighing device. Gear-driven head separation is recommended.

5.1.3 Equip the machine with suitable grips capable of clamping the specimens firmly throughout the tests.

5.1.4 The machine is autographic, giving a chart that can be read in terms of centimetres (inches) of separation as one coordinate and applied load as the other coordinate.

5.1.5 The applied tension as measured and recorded is to be accurate within ± 1 %.

5.2 *Conditioning Room or Desiccators*, capable of maintaining a relative humidity of 50 ± 5 % at $23 \pm 2^\circ\text{C}$.

6. Test Specimen

6.1 Laminated test panels (see [Fig. 1](#)) consist of two semirigid adherends properly prepared and bonded together in accordance with the manufacturer's recommendations. Specially prepared test specimens shall be 25.4 mm (1 in.) wide by 177.3 mm (7 in.) long, but bonded only over approximately 76 mm (3 in.) of their length. Test specimens of these same dimensions may also be cut from larger, fully laminated panels.

6.1.1 Direct comparisons of different adhesives are made only when specimen construction and test conditions are identical.

NOTE 2—General purpose ABS (acrylonitrile-butadiene-styrene) molded plaques approximately 6.3 mm (0.25 in.) thick have been found

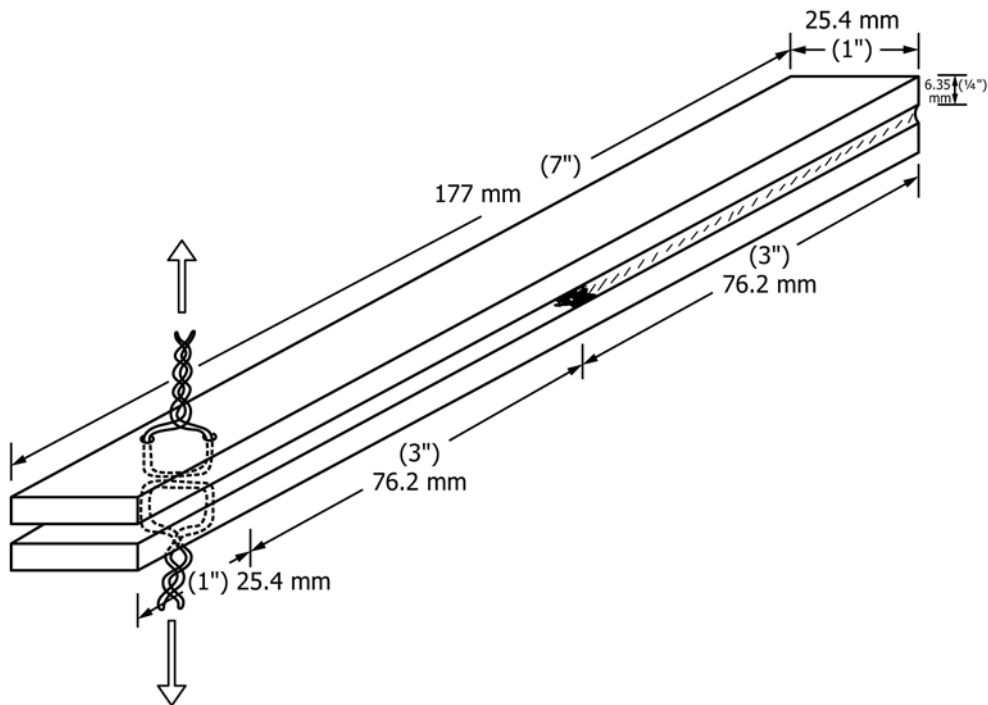

FIG. 1 Cleavage Peel Test Specimen

satisfactory as adherends for structural adhesives. Other engineering plastics and metals have been found satisfactory for specific adhesives.

NOTE 3—The adherend substrate selected must exhibit sufficient toughness and stiffness to resist substrate failure, thus forcing the adhesive layer to absorb the stresses of the testing process. Should the substrate fail cohesively, the ultimate cleavage/peel strength of the adhesive under test has not been determined.

6.2 Cut the bonded panels into 25-mm (1-in.) wide test specimens by a means that is not deleterious to the bond. A suggested cutting process employs a band saw with a 6.3-mm (0.25-in.) thick blade with 18 teeth per 25.4 mm (1 in.) and 12.5 mm (0.5 in.) wide. The feed rate and saw speed is controlled to minimize heat buildup during the sawing process.

6.3 Separate the 101-mm (4-in.) long unbonded ends sufficiently to insert gripping wires for attachment to testing machine jaws.

6.3.1 The gripping wire employed shall be 20-gage steel wire [0.8 mm (0.03 in.) in diameter] attached to the specimen in a manner shown in Fig. 1. Twist the gripping wires together yielding approximately 10 twists per 25 mm (1 in.) of twisted length.

NOTE 4—Alternative methods of gripping wire attachment may be employed if necessary. Sufficient flexibility in the attaching wires must be maintained to allow self-alignment of the gripping wires during the course of the pull testing of the specimens.

6.4 Test at least ten test specimens for each adhesive.

NOTE 5—Within the limitations imposed by 6.1.1 under other specimen widths may be used, provided the test machine grips are of ample width to apply the load uniformly across the width of the adherends.

7. Conditioning

7.1 Condition specimens for three days at a relative humidity of $50 \pm 5\%$ at $23 \pm 2^\circ\text{C}$, except where the adhesive

manufacturer may specify such an aging period to be unnecessary or a shorter period to be adequate.

8. Procedure

8.1 Clamp the connecting wires from the specimen (Fig. 1) in the test grips of the tension-testing machine. Apply the load at a constant crosshead speed of 12.7 mm (0.5 in.)/min.

8.2 During the cleavage/peel test make an autographic recording of load values versus crosshead movement or load versus distance peeled.

8.3 Determine the cleavage/peel resistance over at least a 50.8-mm (2-in.) length of the bond line after the initial peak.

9. Calculation

9.1 Determine the average load (in kilonewtons per metre width of specimen required to separate the adherends) from the autographic curve for the first 50.8 mm (2 in.) of cleavage/peel after the initial peak. It is preferred that the average load be determined from the curve with the use of a planimeter.

NOTE 6—In case a planimeter is not used, the average load may be calculated as the average of load readings taken at fixed increments of crosshead motion. For example, the load may be recorded at each 5-mm (0.2-in.) interval of head motion following the initial peak, until at least seven readings have been obtained.

10. Report

10.1 Report the following information:

10.1.1 Complete identification of the adhesive tested, including type, source, manufacturer code number, batch or lot number, form, etc.

10.1.2 Complete identification of adherends used, including material, thickness, surface preparation, and orientation.

10.1.3 Description of bonding process, including method of application of adhesive, glue-line thickness, drying or pre-curing conditions (where applicable), curing time, temperature, and pressure.

10.1.4 Average thickness of adhesive layer after formation of the joint, within 0.025 mm (0.001 in.). Describe the method of obtaining the thickness of the adhesive layer, including procedure, location of measurement, and range of measurements.

10.1.5 Complete description of test specimens, including dimensions and construction of test specimens, conditions used for cutting individual test specimens, number of test panels represented, and number of individual test specimens.

10.1.6 Conditioning procedure prior to testing.

10.1.7 Type of test machine and crosshead separation rate used.

10.1.8 Method of recording load and determining average load.

10.1.9 Average, maximum, and minimum cleavage/peel load values for each individual specimen.

10.1.10 Average cleavage/peel strength in kilonewtons per metre width for each combination of materials and constructions under test and

10.1.11 Type of failure for each individual specimen.

11. Precision and Bias³

11.1 A precision and bias statement for this test method does not exist because resources necessary for round-robin testing have not been forthcoming.

12. Keywords

12.1 adhesive bonds; cleavage; engineering plastics; peel

³ Results of round-robin tests and supporting data have been filed at ASTM International Headquarters and may be obtained by requesting Research Report RR:D14-1002. Contact ASTM Customer Service at service@astm.org.

ASTM International takes no position respecting the validity of any patent rights asserted in connection with any item mentioned in this standard. Users of this standard are expressly advised that determination of the validity of any such patent rights, and the risk of infringement of such rights, are entirely their own responsibility.

This standard is subject to revision at any time by the responsible technical committee and must be reviewed every five years and if not revised, either reapproved or withdrawn. Your comments are invited either for revision of this standard or for additional standards and should be addressed to ASTM International Headquarters. Your comments will receive careful consideration at a meeting of the responsible technical committee, which you may attend. If you feel that your comments have not received a fair hearing you should make your views known to the ASTM Committee on Standards, at the address shown below.

This standard is copyrighted by ASTM International, 100 Barr Harbor Drive, PO Box C700, West Conshohocken, PA 19428-2959, United States. Individual reprints (single or multiple copies) of this standard may be obtained by contacting ASTM at the above address or at 610-832-9585 (phone), 610-832-9555 (fax), or service@astm.org (e-mail); or through the ASTM website (www.astm.org). Permission rights to photocopy the standard may also be secured from the Copyright Clearance Center, 222 Rosewood Drive, Danvers, MA 01923, Tel: (978) 646-2600; <http://www.copyright.com/>