



Standard Specification for Glass-Fiber-Reinforced Polyester Manholes and Wetwells¹

This standard is issued under the fixed designation D3753; the number immediately following the designation indicates the year of original adoption or, in the case of revision, the year of last revision. A number in parentheses indicates the year of last reapproval. A superscript epsilon (ϵ) indicates an editorial change since the last revision or reapproval.

^ε¹ NOTE—Editorial corrections added in April 2013.

1. Scope*

1.1 This specification covers glass fiber-reinforced polyester manholes and wetwells for use primarily in sanitary and storm sewer applications.

1.2 The values given in inch-pound units are to be regarded as the standard. The values in parentheses are provided for information purposes only.

1.3 The following precautionary caveat pertains only to the test methods portion, Section 8, of this specification: *This standard does not purport to address all of the safety concerns, if any, associated with its use. It is the responsibility of the user of this standard to establish appropriate safety and health practices and determine the applicability of regulatory limitations prior to use.*

NOTE 1—There is no known ISO equivalent to this standard.

2. Referenced Documents

2.1 ASTM Standards:²

- D581 Practice for Determining Chemical Resistance of Thermosetting Resins Used in Glass-Fiber-Reinforced Structures Intended for Liquid Service
- D695 Test Method for Compressive Properties of Rigid Plastics
- D785 Test Method for Rockwell Hardness of Plastics and Electrical Insulating Materials
- D790 Test Methods for Flexural Properties of Unreinforced and Reinforced Plastics and Electrical Insulating Materials
- D883 Terminology Relating to Plastics
- D1600 Terminology for Abbreviated Terms Relating to Plastics

¹ This specification is under the jurisdiction of ASTM Committee D20 on Plastics and is the direct responsibility of Subcommittee D20.23 on Reinforced Plastic Piping Systems and Chemical Equipment.

Current edition approved March 15, 2012. Published April 2012. Originally approved in 1979. Last previous edition approved in 2005 as D3753 – 05^{ε1}. DOI: 10.1520/D3753-12E01.

² For referenced ASTM standards, visit the ASTM website, www.astm.org, or contact ASTM Customer Service at service@astm.org. For *Annual Book of ASTM Standards* volume information, refer to the standard's Document Summary page on the ASTM website.

- D2412 Test Method for Determination of External Loading Characteristics of Plastic Pipe by Parallel-Plate Loading
- D2583 Test Method for Indentation Hardness of Rigid Plastics by Means of a Barcol Impressor
- D2584 Test Method for Ignition Loss of Cured Reinforced Resins
- D3892 Practice for Packaging/Packing of Plastics

3. Terminology

3.1 *General*—Definitions are in accordance with Terminology D883 and the abbreviations are in accordance with Terminology D1600 unless otherwise indicated.

3.2 *bench and invert, n*—internal flow channel with a sloped bench extending from the edge of the flow channel to the manhole wall designed to facilitate the flow of liquid through the manhole between the pipe connectors.

3.3 *bottom, n*—a flat, domed, dished, or other shaped bottom designed to make the manhole or wetwell watertight at its base.

3.4 *expanded base manhole, n*—a manhole with the addition of eccentric or concentric reducers attached to cylinder sections of different diameter than the manhole to allow changes in cylinder diameter.

3.5 *manway reducer, n*—the top portion of the manhole through which entrance to the manhole is made and where the diameter increases from the entrance way to the larger manhole cylinder.

3.6 *manhole, n*—a constant diameter cylinder attached to a manway reducer designed to handle a manhole cover and ring.

3.7 *manhole cover and ring, n*—those accessories used with the manhole to close the manway entrance (includes adjustment rings).

3.8 *manhole cylinder, n*—the portion below the manway reducer that extends in a constant diameter to the manhole base.

3.9 *pipe connectors, n*—connectors that provide access for the sewer pipe into the manhole.

3.10 *resin rich, adj*—describes that portion of the glass fiber-reinforced polyester material where the resin-to-glass ratio is significantly greater than in other portions of the manhole.

*A Summary of Changes section appears at the end of this standard

3.11 *wetwell, n*—a cylinder without a manway reducer, which may be open at the top or may include a flat top.

4. Materials

4.1 *Resin*—The resins used shall be a commercial grade unsaturated polyester resin.

4.2 *Reinforcing Materials*—The reinforcing materials shall be commercial grade of E-type glass fibers in the form of mat, continuous roving, chopped roving, or roving fabric, having a coupling agent that will provide a suitable bond between the glass reinforcement and the resin.

4.3 *Surfacing Material*—If reinforcing material is used on the surface exposed to the contained substance, it shall be a commercial grade chemical-resistant glass or organic surfacing mat having a coupling agent that will provide a suitable bond with the resin.

4.4 *Fillers and Additives*—Fillers, when used, shall be inert to the environment and manhole construction. Additives, such as thixotropic agents, catalysts, promoters, pigments, etc., may be added as required by the specific manufacturing process to be used to meet the requirements of this standard. The resulting reinforced-plastic material shall meet the requirement of this specification.

4.5 *Other*—Polyester continuous roving, polyester scrim, glass scrim, or other material, may be used. The resulting reinforced-plastic material shall meet the requirement of this specification.

4.6 *Ribs*—When used, ribs may be manufactured as a solid construction or with materials applied over a structural or non-structural form. The resulting reinforced-plastic material shall meet the requirement of this specification.

5. Manufacture

5.1 Manhole, wetwells, manway reducers, eccentric or concentric reducers, connectors, and bottoms shall be produced from glass fiber-reinforced polyester resin with construction determined by the particular process of manufacture and configuration. The process may include contact molding, compression molding, pultrusion, filament winding, resin transfer molding, spray up, hand lay-up, centrifugal casting, vacuum bagging, or other methods. Ribs may be attached to the interior or the exterior surface.

5.2 *Interior Access*—All manholes or wetwells shall be designed so that a ladder or step system can be supported by the installed manhole or wetwell.

5.3 *Manway Reducer*—Manway reducers may be eccentric or concentric with respect to the larger portion of the manhole.

5.4 *Cover and Ring Support*—Manholes shall provide an area from which a typical ring and cover plate can be supported without damage to the manhole.

5.5 *Assembly Joints*—Product segments may be joined together to form a complete manhole or wetwell.

5.6 *Manhole or Wetwell Bottom*—Shall be designed to be water tight and withstand the external hydraulic pressure of water to grade. The bottom design may include methods to

anchor the bottom to a concrete base or other external structure to provide the required resistance to external pressure.

5.7 *Bench and Invert*—May be produced from glass fiber-reinforced polyester resin or other material suitable for the contents of the manhole. The bench and invert may include one or more 1/2-in. diameter holes to allow the equalization of pressure between the manhole interior and the area under the bench and invert.

6. Requirements

6.1 Workmanship:

6.1.1 *Exterior Surface*—The exterior surface shall be relatively smooth with no sharp projections. Hand-work finish is acceptable if enough resin is present to saturate all fibers. The exterior surface shall be free of blisters larger than 0.5 in. (12.7 mm) in diameter and delamination. Fibers loosely attached (can be removed with wire brush) are allowed if not excessive.

6.1.2 *Exterior Paint or Pigmentation*—Paint, coatings, or high levels of pigmentation that impair the visual inspection of the laminate for excessive amounts of captured air, blisters, or other defects are not allowed.

6.1.3 *Indentations*—Indentations or other shape imperfections that will not affect performance are allowed.

6.1.4 *Interior Surface*—The interior surface shall be resin rich with no exposed fibers. The surface shall be free of crazing, delamination, blisters larger than 0.5 in. (12.7 mm) in diameter, and wrinkles of 0.125 in. (3.2 mm) or greater in depth. Surface pits shall be permitted up to 6/ft² (60/m²) if they are less than 0.75 in. (19 mm) in diameter and less than 0.0625 in. (1.6 mm) deep. Voids that cannot be broken with finger pressure and that are entirely below the resin surface shall be permitted up to 4/ft² (40/m²) if they are less than 0.5 in. (12.7 mm) in diameter and less than 0.0625 in. (1.6 mm) thick.

6.1.5 *Interior Paint or Pigmentation*—Paint, coatings, or high levels of pigmentation that impair the visual inspection of the laminate for excessive amounts of captured air, blisters, or other defects are not allowed.

6.2 *Repairs*—Any manhole or wetwell may be repaired to meet all requirements of this specification.

6.3 *Dimensions*—The dimensions shall be as shown below when measured in accordance with 8.3.1.

6.3.1 Minimum cylinder internal diameter of the manhole or wetwell shall be 42 in. (1057 mm). The minimum reducer inside diameter shall be 21 in. (533 mm).

6.3.2 Manhole or wetwell lengths shall be in 6-in. (152-mm) increments ± 2 in. (51 mm).

6.3.3 Nominal inside diameters shall be 42 in. (1067 mm), 48 in. (1219 mm), 54 in. (1372 mm), 60 in. (1524 mm), 66 in. (1676 mm) and 72 in. (1829 mm). Tolerance on the inside diameter shall be ± 1 %. Other diameters as agreed upon between the purchaser and the manufacturer are covered by this specification.

6.4 *Manhole Performance Test*—One complete manhole manufactured in a manner consistent in every way with this specification shall meet the performance criteria in 6.4.1 – 6.4.3. If a change in materials or methods of manufacturing is made and that change may affect the results of these tests, then

the testing shall be repeated. These tests are to be conducted on a representative manhole to qualify the finished product characteristics. They are not considered to be a quality control procedure and are not required for production parts.

6.4.1 *Load Rating*—The complete manhole shall have a minimum dynamic-load rating of 16 000 lbf (71 172 N) when tested in accordance with 8.4. To establish this rating, the complete manhole shall not leak, crack, or suffer other damage when load tested to 40 000 lbf (177 929 N) and shall not deflect vertically downward more than 0.25 in. (6.35 mm) at the point of load application when loaded to 24 000 lb (106 757 N).

6.4.2 *Stiffness*—The manhole cylinder shall have the minimum pipe-stiffness values shown in Table 1 when tested in accordance with 8.5. Stiffness requirements for other manhole lengths may be interpolated between the values in Table 1.

6.4.3 *Soundness*—The manholes shall not leak when tested in accordance with 8.6.

6.5 *Wetwell Stiffness*—The wetwell cylinder shall have the minimum pipe-stiffness values shown in Table 1 when tested in accordance with 8.5. Stiffness requirements for other wetwell lengths may be interpolated between the values in Table 1. These tests are to be conducted on a representative wetwell to qualify the finished product characteristics. They are not considered to be a quality control procedure and are not required for production parts.

6.6 *Chemical Resistance*—Manhole or wetwell samples manufactured in a manner consistent in every way with this specification shall be tested in accordance with 8.7. The log of percent retention of each property after immersion testing when plotted against the log of immersion time, and extrapolated to 100 000 h shall assure retention of at least 50 % of initial properties. If a change is made in the manhole construction and that change may affect the results of the chemical resistance testing, then the testing shall be repeated. Chemical testing is conducted to determine the applicability of the materials used in the manufacture of the manhole to the specified use conditions. It is not considered to be a quality control procedure.

6.7 *Material Properties*—The following properties shall be established for each type of construction used in the manhole or wetwell. If a change in materials or methods of manufacturing is made and that change may affect the results of the following tests, then the testing shall be repeated. Material properties tests are conducted to qualify the finished product characteristics. They are not considered to be a quality control procedure and are not required for production parts.

TABLE 1 Stiffness Requirements

Manhole or Wetwell Length, ft (mm)	$F/\Delta Y$, psi (kPa)
6 (1829)	0.72 (4.96)
12 (3658)	1.26 (8.69)
20 (6096)	2.01 (13.86)
25 (7620)	3.02 (20.82)
35 (10668)	5.24 (36.13)

6.7.1 *Material Composition*—The material composition of the manhole or wetwell in percent by weight shall be determined in accordance with 8.8.1.

6.7.2 *Compressive Strength*—The compressive strength in the hoop and axial directions of the manhole or wetwell shall be determined in accordance with 8.8.2.

6.7.3 *Flexural Strength and Modulus*—The flexural strength and flexural modulus of elasticity, in the hoop and axial directions of the manhole or wetwell, shall be determined in accordance with 8.8.3. Where part geometry will adversely affect the test results (an example would be flexural testing on curved samples taken in the hoop direction), hand fabricated samples made consistent with the materials and construction of the manhole or wetwell may be used for testing.

6.8 *Hardness*—The surface hardness of the manhole or wetwell shall be determined in accordance with 8.8.4.

6.9 *Thickness*—The thickness of each manhole or wetwell component part shall be determined in accordance with 8.3.2.

6.10 *Field Vacuum Test Capability*—Each manhole or wetwell shall be capable of withstanding a field applied test vacuum of -5 psi (-34 kPa) gauge.

7. Quality Control

7.1 *Examination*—Each manhole or wetwell component part shall be examined for workmanship dimensions, hardness, and thickness in accordance with Section 6.

7.2 *Composition Control*—Controls on glass and resin content shall be maintained for all manhole or wetwell manufacturing processes. Records shall be maintained as needed to ensure products meet the requirements of the specification. Proper glass content may be shown by glass usage checks, by glass and resin application rate checks, or material composition testing in accordance with 8.8.1.

8. Test Methods

8.1 *Conditioning*—Specimens tested shall be representative of the actual manufacturing process. Conditioning of the specimens is not allowed unless specified by this specification.

8.2 *Test Conditions*—Conduct at ambient temperature without any special controls on temperature unless otherwise specified.

8.3 Dimensions:

8.3.1 Measure dimensions other than thickness with a steel tape with graduations of 0.125 in. (3 mm) or less.

8.3.2 *Thickness*—Measure to the nearest 0.01 in. (0.25 mm) with a micrometer, caliper, gauge, or other suitable instrument. Make a minimum of one thickness reading per 34 ft² (3 m²) of surface in areas of constant thickness. Through regions of wall taper, make sufficient checks to establish the actual thickness.

8.4 Load Rating:

8.4.1 *Load Test*—The manhole tested shall be long enough to include at least one of all unique or repetitive features such as: bonded joints, adhesive seams, gasketed joints, etc., except for reducers and cylinder sections of a different diameter than

the manhole. In any case, the minimum length of the manhole cylinder shall not be less than 36 in. (914 mm) for each cylinder diameter.

8.4.1.1 *Concentric Manholes*—The manhole to be tested shall be complete with cover and supporting ring installed. Apply the specified load eccentrically (see Fig. 1 for typical test model) on a 6 in. by 6 in. by ½ in. (152 mm by 152 mm by 12.7 mm) steel plate resting on the manhole cover. Locate the steel loading plate so that the center of the plate is within 4 in. (102 mm) from the edge of the cover. Load in 2000-lbf (8896-N) increments with close inspection between increases. Maintain the specified load for not less than 15 min.

8.4.1.2 *Eccentric Manholes*—The manhole to be tested shall be complete with cover and supporting ring installed. Apply the specified load eccentrically (see Fig. 2 for typical test model) 6 in. by 6 in. by ½ in. (152 mm by 152 mm by 12.7 mm) steel plate resting on the manhole cover. Locate the steel loading plate so that the center of the plate is within 4 in. (102 mm) from the edge of the cover at a point where the edge of the cover is nearest to the axis of the manhole cylinder. Load in 2000-lbf (8896-N) increments with close inspection between increases. Maintain the specified load for not less than 15 min.

8.4.2 *Deflection Test*—When load tested according to the procedure as outlined in 8.4.1.1 and 8.4.1.2 the top of the manhole(s) shall not deflect vertically downward more than 0.25 in. (6.35 mm) when measured at the point of load application when the specified load is 24 000 lbf (106 757 N).

8.4.3 *Expanded Base Manholes* that have had their manhole portion tested in accordance with 8.4.1 and 8.4.2 may include reducers and attached cylinder sections designed by the manufacturer to carry the loads in 8.4.1 without load testing. Generally accepted design methods may be used including closed form solutions, or finite element analysis (FEA), or

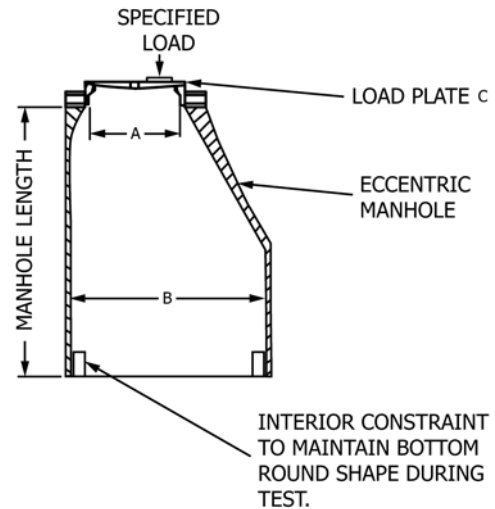

Table of Dimensions

	in.	(mm)
A	21 min	(533 min)
B	42 min	(1067 min)
C	6 by 6 by ½	(152 by 152 by 12.7)

FIG. 2 Eccentric Manhole Load Test Model

both. The calculations shall show that the entire expanded base manhole will meet the requirements of 8.4.2.

8.5 *Manhole or Wetwell Stiffness*—Test a section of the cylinder portion of the manhole or wetwell in accordance with Test Method D2412. The section tested shall be free of any joints, repetitive features, or repairs.

8.6 *Manhole Soundness*—In order to determine soundness, apply an air or water pressure test, or both to the manhole test sample described in 8.4.1. The test pressure shall not be less than 3 psig (20.68 kPa) or greater than 5 psig (34.47 kPa). While holding at the established pressure, inspect the entire manhole for leaks. Any leakage through the laminate, joints, or repairs is cause for failure of the test. (**Warning**—Care shall be taken in the air test ensuring that the test is run in an isolated or confined area. The preferred method is to fill the manhole with water and add air pressure.)

8.7 *Chemical Resistance*—The testing procedure for measuring chemical resistance shall conform with Practice C581 with the exceptions noted below.

8.7.1 *Test Specimen Construction*—Make the basic test specimen in a manner consistent in every way with the manhole or wetwell construction. This includes, among other considerations, percent glass, type of glass, resin type, catalyst system, post-cure (if any), fillers and additives (if any), and the exclusion or not of air from the laminate surfaces. Test specimens shall be tested in their as-manufactured state with no conditioning. Each specimen shall be large enough to allow a minimum of three individual flexural test samples.

8.7.1.1 If the specimen is to be tested in an environment simulating a contained substance, a resin-rich layer may be added to the exterior portion of the specimen. This second

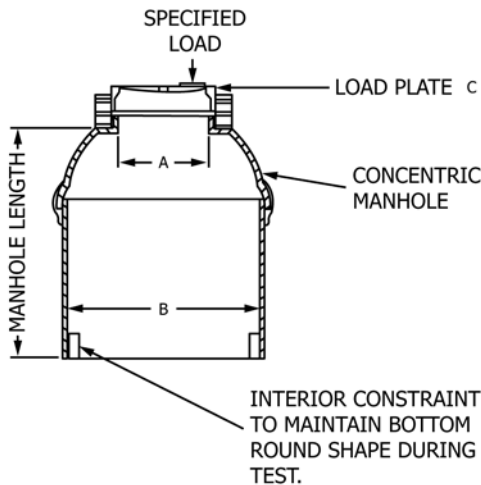

Table of Dimensions

	in.	(mm)
A	21 min	(533 min)
B	42 min	(1067 min)
C	6 by 6 by ½	(152 by 152 by 12.7)

FIG. 1 Concentric Manhole Load Test Model

resin-rich surface, not present in the manhole itself, shall be of the same construction and thickness; and made with the same considerations (that is, exclusion of air) as the primary layer on the opposite side of the specimen. Where a dual-resin construction is used, this second resin-rich layer shall employ the same resin as the primary layer. Seal cut edges with the resin used in the resin-rich surfaces.

8.7.1.2 If the specimen is to be tested in an environment simulating soil conditions, it shall be that described in 8.7.1. Seal cut edges of the specimen with that resin used in the outer surface of the manhole.

8.7.2 *Test Intervals*—Test specimens after one, three, six, and twelve months immersions in each test medium. It may be advisable to include an extra specimen at the time of initial immersion in the event it is necessary to extend the test interval beyond one year because of inconclusive results at that time. Cut each specimen into at least three samples for flexural tests.

8.7.3 *Test Media*—Test media shall represent as completely as possible the actual environment of the manhole or wetwell in service. Throughout the test period, change the test media as required to maintain the properties of the test media.

8.7.3.1 *Interior Surface*—The required test medium for the interior surface shall be the material to be contained in the manhole or wetwell. When raw sewage is the medium, the sewage shall be replenished to maintain initial biochemical oxygen demand (BOD) levels. Raw sewage may also be simulated with 5 % sulfuric acid.

8.7.3.2 *Exterior Surface*—Test the following media representing the exterior surface environment:

- (a) Sodium chloride, saturated solution.
- (b) Standard buffer aqueous solution at 73°F (22.8°C) simulating alkaline soil (pH of 10).
- (c) Standard buffer aqueous solution at 73°F (22.8°C) simulating acidic soil (pH of 4).

8.7.4 *Test Temperatures*—The temperature of each test medium used in corrosion-resistance verification of the manhole or wetwell interior shall be the maximum suggested service temperature for that medium. All media representing soil conditions and sanitary sewage shall be 73°F (22.8°C).

8.7.5 *Interpretation of Results:*

8.7.5.1 Properties to be determined initially and after each test period are flexural strength and flexural modulus (both in accordance with Test Methods D790, Method I, Procedure A), and Barcol hardness (in accordance with Test Method D2583) of the interior of the laminate. The specimen shall not be cured and shall represent the as-manufactured state of cure.

8.7.5.2 Note any effect upon the immersion medium or specimen observed during visual inspection and use to augment physical data in determining the suitability of the manhole or wetwell in any given medium.

8.7.5.3 Plot the average log of percent retention of each property (see 8.7.5.1) for all samples (at least three samples per specimen, see 8.7.3.2) after immersion testing (versus initial) against the log of immersion time in hours (see Fig. 3).

8.8 *Material Properties*—Specimens taken from a manhole or wetwell shall be used, if possible, to establish material properties. If it is not possible to take the specimens from a manhole or wetwell because of dimensional requirements for testing, make the specimens independently but, in any case, they shall be consistent in all respects with the construction of the manhole or wetwell. Test specimens shall be tested in their as-manufactured state with no conditioning.

8.8.1 *Material Composition*—Determine composition in accordance with Test Method D2584. For specimens with fillers or additives, or both, separate the residue into its components (glass, sand, etc.) to determine the glass content.

8.8.2 *Compressive Strength*—Determine compressive strength in accordance with Test Method D695.

8.8.3 *Flexural Strength and Modulus*—Determine flexural strength and flexural modulus of elasticity in accordance with Test Methods D790. Strength property test methods may require flat specimens constructed consistently with the method of fabrication selected for the manhole.

8.8.4 *Hardness*—Determine Rockwell hardness in accordance with Test Method D785 or Barcol hardness in accordance with Test Method D2583. The frequency of checks shall not be less than three random points per component part. The

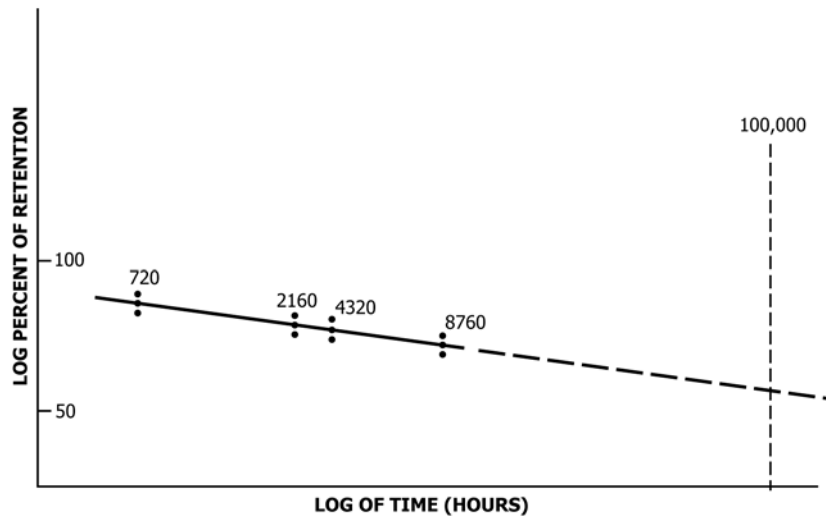

FIG. 3 Chemical Test Property Retention

minimum acceptable value of cure shall not be less than 90 % of the resin manufacturers minimum value for the cured resin.

9. Inspection

9.1 Inspection of finished manholes and wetwells shall be made as agreed upon between the purchaser and the supplier as part of the purchase contract.

10. Rejection and Rehearing

10.1 Manholes or wetwells that fail to conform to the requirements of this specification may be rejected. Rejection shall be reported to the manufacturer or supplier promptly and in writing. In case of dissatisfaction with the results of any test, the manufacturer or supplier may make a claim for a rehearing.

11. Certification

11.1 When requested by the purchaser on his order, a certification shall be made the basis of acceptance. This shall

consist of a copy of the manufacturer's test report or a statement by the supplier, accompanied by a copy of the test results, that the manhole or wetwell has been tested, and inspected in accordance with the provisions of this specification and meets all requirements. Each certification so furnished shall be signed by an authorized agent of the supplier or manufacturer.

12. Packaging and Package Marking

12.1 The manholes shall be marked with the following information:

- 12.1.1 This ASTM designation,
- 12.1.2 Manufacturer's name or trademark,
- 12.1.3 Manufacturing serial number, and
- 12.1.4 Manhole total length.

12.2 All packing, packaging, and marking provisions of Practice **D3892** shall apply to this specification.

SUMMARY OF CHANGES

Committee D20 has identified the location of selected changes to this standard since the last issue (D3753 - 05^{e1}) that may impact the use of this standard. (March 15, 2012)

- (1) Section **3**—Added new definitions used in the standard and clarified differences between manholes and wetwells.
- (2) Section **5**—Added new terms, clarified requirements for paint and pigmentation, separated requirements between those that apply only to manholes from those that apply only the wetwells.

- (3) Section **8**—Included expanded base manholes and separated requirements between those that apply only to manholes from those that apply only the wetwells.
- (4) **Table 1**—Added wetwell to table for required stiffness.

ASTM International takes no position respecting the validity of any patent rights asserted in connection with any item mentioned in this standard. Users of this standard are expressly advised that determination of the validity of any such patent rights, and the risk of infringement of such rights, are entirely their own responsibility.

This standard is subject to revision at any time by the responsible technical committee and must be reviewed every five years and if not revised, either reapproved or withdrawn. Your comments are invited either for revision of this standard or for additional standards and should be addressed to ASTM International Headquarters. Your comments will receive careful consideration at a meeting of the responsible technical committee, which you may attend. If you feel that your comments have not received a fair hearing you should make your views known to the ASTM Committee on Standards, at the address shown below.

This standard is copyrighted by ASTM International, 100 Barr Harbor Drive, PO Box C700, West Conshohocken, PA 19428-2959, United States. Individual reprints (single or multiple copies) of this standard may be obtained by contacting ASTM at the above address or at 610-832-9585 (phone), 610-832-9555 (fax), or service@astm.org (e-mail); or through the ASTM website (www.astm.org). Permission rights to photocopy the standard may also be secured from the Copyright Clearance Center, 222 Rosewood Drive, Danvers, MA 01923, Tel: (978) 646-2600; <http://www.copyright.com/>