



Standard Test Method for Chemical Resistance of “Fiberglass” (Glass–Fiber–Reinforced Thermosetting-Resin) Pipe in a Deflected Condition¹

This standard is issued under the fixed designation D3681; the number immediately following the designation indicates the year of original adoption or, in the case of revision, the year of last revision. A number in parentheses indicates the year of last reapproval. A superscript epsilon (ϵ) indicates an editorial change since the last revision or reapproval.

^ε¹ NOTE—Editorially corrected [Table A1.2](#) in March 2014.

1. Scope*

1.1 This test method covers the procedure for determining the chemical-resistant properties of fiberglass pipe in a deflected condition for diameters 4 in. (102 mm) and larger. Both glass–fiber–reinforced thermosetting resin pipe (RTRP) and glass–fiber–reinforced polymer mortar pipe (RPMP) are fiberglass pipes.

NOTE 1—For the purposes for this standard, polymer does not include natural polymers.

1.2 Inch-pound units are to be regarded as the standard. The values given in parentheses are for information only.

1.3 *This standard does not purport to address all of the safety concerns, if any, associated with its use. It is the responsibility of the user of this standard to establish appropriate safety and health practices and determine the applicability of regulatory limitations prior to use.* Specific precautionary statements are given in [9.5](#).

NOTE 2—There is no known ISO equivalent to this standard.

2. Referenced Documents

2.1 ASTM Standards:²

[D883 Terminology Relating to Plastics](#)

[D1600 Terminology for Abbreviated Terms Relating to Plastics](#)

[D3567 Practice for Determining Dimensions of “Fiberglass” \(Glass-Fiber-Reinforced Thermosetting Resin\) Pipe and Fittings](#)

¹ This test method is under the jurisdiction of ASTM Committee D20 on Plastics and is the direct responsibility of Subcommittee D20.23 on Reinforced Plastic Piping Systems and Chemical Equipment.

Current edition approved April 1, 2012. Published May 2012. Originally approved in 1978. Last previous edition approved in 2006 as D3681 – 06. DOI: 10.1520/D3681-12E01.

² For referenced ASTM standards, visit the ASTM website, www.astm.org, or contact ASTM Customer Service at service@astm.org. For *Annual Book of ASTM Standards* volume information, refer to the standard’s Document Summary page on the ASTM website.

2.2 ISO Standard:

[3 Preferred Numbers—Series of Preferred Numbers](#)³

3. Terminology

3.1 Definitions:

3.1.1 *General*—Definitions are in accordance with Terminology [D883](#) and abbreviations are in accordance with Terminology [D1600](#) unless otherwise indicated.

3.2 Definitions of Terms Specific to This Standard:

3.2.1 *end point*—the passage of the fluid through the pipe wall unless otherwise stated. The failure mode may be catastrophic, characterized by a sudden fracture through the pipe wall in the area of greatest strain, parallel to the axis of the pipe, with the fiber reinforcement cleanly broken at the edge of the fracture. Visual evidence of surface etching or pitting may or may not be present.

3.2.2 *fiberglass pipe*—tubular product containing glass fiber reinforcements embedded in or surrounded by cured thermosetting resin. The composite structure may contain aggregate, granular or platelet fillers, thixotropic agents, pigments, or dyes. Thermoplastic or thermosetting liners or coatings may be included.

3.2.3 *reinforced polymer mortar pipe (RPMP)*—fiberglass pipe with aggregate.

3.2.4 *reinforced thermosetting resin pipe (RTRP)*—fiberglass pipe without aggregate.

3.2.5 *strain-corrosion*—the failure of the pipe wall caused by the exposure of the inside surface, while in a strained condition, to a corrosive environment for a period of time.

4. Summary of Test Method

4.1 This test method consists of exposing the interior of a minimum of 18 specimens of pipe to a corrosive test solution while the pipe is constantly maintained in a deflected condition at differing induced initial ring flexural strain levels, and

³ Available from American National Standards Institute (ANSI), 25 W. 43rd St., 4th Floor, New York, NY 10036, <http://www.ansi.org>.

*A Summary of Changes section appears at the end of this standard

measuring the time to failure for each strain level. Test temperatures are obtained by testing in an air environment where the temperature is controlled.

4.2 The long-term resistance of the pipe to the test solution is obtained by an extrapolation to 50 years of a log-log linear regression line for initial strain level versus time.

NOTE 3—It is the consensus of Subcommittee D20.23 that the log-log linear regression analysis of test data is a conservative approach and is representative of standard industry practice. However, a task group has been formed to evaluate alternative non-linear analysis methods.

5. Significance and Use

5.1 This test method evaluates the effect of a chemical environment on pipe when in a deflected condition. It has been found that effects of chemical environments can be accelerated by strain induced by deflection. This information is useful and necessary for the design and application of buried fiberglass pipe.

NOTE 4—Pipe of the same diameter but of different wall thicknesses will develop different strains with the same deflection. Also, pipes having the same wall thickness but different constructions making up the wall may develop different strains with the same deflection.

6. Apparatus

6.1 Use parallel plate apparatus suitable to maintain a constant deflection on the pipe. In order to achieve uniform strain along the pipe, use 0.25-in. (6-mm) thick elastomeric pads between the parallel plate (channel) surfaces and the pipe ring (see Note 5). Foil type, single element strain gages suitable for strain levels to 1.50 % strain and a length appropriate to the diameter of the pipe are required when initial strain is to be determined by Procedure B (see Note 6). An example of the apparatus required is shown in Fig. 1.

NOTE 5—Elastomeric pads with a hardness of Shore A15 to 70 have been used successfully.

NOTE 6—Strain gages of ¼ and ½-in. (6 and 13-mm) length have been found to be effective for pipe diameters 12 through 24 in. (305 through 610 mm). Consult the strain gage manufacturer for gage length recom-

mendations for other pipe diameters.

7. Test Specimens

7.1 The test specimens shall be ring sections taken from a sample of pipe selected at random from a normal production run. The test specimens shall have a minimum length of one nominal pipe diameter or 12 in. (300 mm) ± 5 %, whichever is less.

8. Test Conditions

8.1 The standard temperature shall be 73.4 ± 3.6°F (23 ± 2°C).

9. Procedure

9.1 *General*—Determine the initial strain level induced in the pipe by calculation, or strain gage measurement, or both. Procedure A describes the determination of initial strain by calculation; Procedure B describes the determination of initial strain as obtained by use of foil-type resistance strain gages.

9.2 *Determination of Test Level:*

9.2.1 *Test Procedure A:*

9.2.1.1 In accordance with Practice D3567 measure the wall thickness to the nearest 0.001 in. (0.025 mm) in at least five equally spaced places along the bottom of the pipe specimen on a line parallel with the pipe axis, and average the measurements.

9.2.1.2 In accordance with Practice D3567 measure the vertical inside diameter to the nearest 0.01 in. (0.25 mm) at both ends prior to deflection and average the measurements.

NOTE 7—It is recommended that the vertical inside diameter be measured with the axis vertical.

9.2.1.3 Place the pipe specimen in the test apparatus (Fig. 1) with the measured wall thicknesses at the bottom and apply force to the apparatus to deflect the specimen while keeping the top and bottom plates (channels) of the apparatus as near

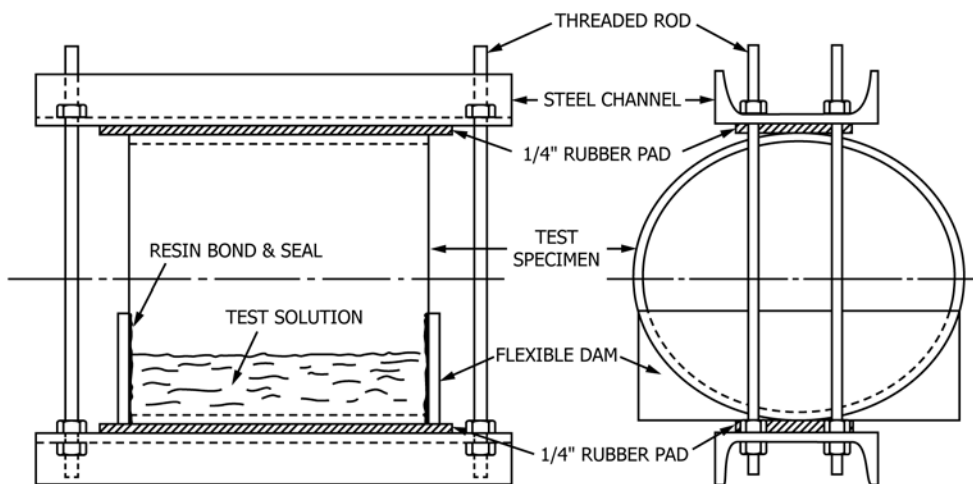

FIG. 1 Strain-Corrosion Test Apparatus

parallel as possible. When the desired deflection is obtained, lock the apparatus to maintain the specimen in the deflected condition.

NOTE 8—Alignment of the specimen within the channels is critical. The channels must not only be parallel with the load points 180° opposite, but the pipe must be centered between the rods.

9.2.1.4 Measure the vertical inside diameter of the deflected pipe specimen at both ends to the nearest 0.01 in. (0.25 mm). Average the measurements and determine the deflection by subtracting the average vertical inside diameter after deflection from the measurement determined in 9.2.1.2.

9.2.1.5 Calculate the initial strain level using the following equation which includes compensation for increased horizontal diameter with increasing deflection.

$$\varepsilon_T = \frac{428(t)(\Delta)}{\left(D_m + \frac{\Delta}{2}\right)^2}$$

where:

- ε_T = initial strain, %,
- t = average wall thickness at bottom, in. (mm),
- Δ = average deflection, in. (mm),
- D_m = mean diameter, in. (mm) $\bar{D} + t$, and
- \bar{D} = average inside pipe diameter, free state, in. (mm).

NOTE 9—The calculation assumes that the neutral axis is at the pipe wall midpoint. For pipe wall constructions that produce an altered neutral axis position, it may be necessary to evaluate results substituting $2\bar{y}$ for t . (\bar{y} is the distance from the inside pipe surface to the neutral axis.) Neutral axis position must be determined with strain gage couples. See also Note 11.

9.2.2 Procedure B:

9.2.2.1 Carefully align and attach three strain gages on the inside bottom surface of the pipe specimen in the circumferential direction to measure initial circumferential strains. Place the gages perpendicular to the pipe axis as follows: one in the middle and the other two at the quarter points along the invert of the specimen. The adhesive used to attach the gages shall not cover more than 37 % of the pipe specimen length along the invert. Zero-in the gages while the pipe is circular in shape.

NOTE 10—It is recommended that the pipe specimen be placed with its axis vertical to maintain roundness when the bridge is balanced to “zero” the instrument.

9.2.2.2 After installing the strain gages, place the specimen in the test apparatus (see Fig. 1) with the strain gages at the bottom. Extreme care should be taken to ensure that the gages are located at the point of maximum strain (6 o’clock position).

NOTE 11—Alignment of the specimen within the channels is critical. The channels must not only be parallel with the load points 180° opposite, but the pipe must be centered between the rods.

9.2.2.3 Apply force to the apparatus to deflect the specimen while keeping the top and bottom plates (channels) of the apparatus as parallel as possible. When the desired strain level is reached, lock the apparatus to maintain the specimen in the deflected condition. Read the gages as soon as the apparatus is locked. Initial strain should be recorded within 2 min after locking the apparatus. At least two gages shall read within 5 %

of each other for a valid experiment. If any gage reads more than 5 % from the average of the other two gages, disregard the indication unless thickness verification implies the strain gage reading was accurate. Average the valid gage indications, and record as initial (indicated) strain. In addition, measure and record the deflection.

9.3 When using Procedure A, verify the strain level by using strain gages as described in Procedure B for at least one specimen in every nine. Conversely, when using Procedure B, verify the strain level by measurement and calculation as described in Procedure A for at least one specimen in every nine. If the calculated strain and the indicated strain do not vary more than 10 %, consider the strain levels accurate within normal experimental error.

NOTE 12—Deflections in excess of 28 % of diameter may cause local flattening of the pipe and lead to erratic strain distribution. For deflections approaching 28 % improved accuracy is obtained by use of strain gages or by establishing, for a typical pipe, a calibration of deflection versus measured strain. This calibration technique is also useful at all deflection levels as a check of the calculations by 9.2.1.5, which assumes neutral axis at pipe wall midpoint.

9.4 After the initial strain is obtained using Procedure A or B, install chemically inert dams using a flexible sealant so that only the interior surface of the pipe will be exposed to the test environment. The dams shall not add support to the pipe specimen.

9.5 Place the apparatus containing the specimen in a chemically resistant trough or pan and introduce the test solution. The solution should be added within 30 min of locking the apparatus and the time should be recorded from the addition of the solution. (**Warning**—Since the failure mode could be catastrophic, precautions should be taken to contain any sudden leakage that may occur. The use of spacers (such as, wooden blocks) under the apparatus is suggested to reduce attack of the apparatus after failure of the sample.)

9.6 Periodically check and maintain the test solution within ± 5 % of the specified strength or concentration for the duration of the test. Maintain the level at a depth of not less than 1 in. (25.4 mm) during the period of the test.

NOTE 13—As some solutions become more concentrated with the evaporation of water, care must be exercised in replenishment to prevent a build-up in strength. It may be necessary, with some reagents, to periodically clean the deflected specimen and replace the test solution with a fresh mixture. The use of plastic film, cut carefully to fit between the dams and floated on the top of the test solution, has been found helpful in reducing evaporation.

9.7 Record the following data:

9.7.1 Average pipe wall thickness,

9.7.2 Average inside pipe diameter before deflection,

9.7.3 Average inside pipe diameter after deflection,

9.7.4 Percent deflection,

9.7.5 Initial strain and method of determination,

9.7.6 Type, location, and time of any distress of the pipe wall, and

9.7.7 Time to end point. Times are measured from the addition of solution.

9.8 To determine the regression line and the lower confidence level for the report, a minimum of 18 samples is required. Distribution of data points should be as follows:

Hours	Failure Points
10 to 1000	at least 4
1000 to 6000	at least 3
After 6000	at least 3
After 10 000	at least 1

9.9 Perform inspection of the test samples as follows:

Hours	Inspect at Least
10 to 20	every 1 h
20 to 40	every 2 h
40 to 60	every 4 h
60 to 100	every 8 h
100 to 600	every 24 h
600 to 6000	every 48 h
After 6000	every week

Record the time to end point for each specimen.

NOTE 14—The use of electronic timers is considered highly desirable in monitoring failure time particularly on short term tests.

9.10 Analyze the test results by using for each specimen, the logarithm of the strain in percent and the logarithm of the time-to-failure in hours as described in **Annex A1**. Calculate the strain at 50 years (YL).

9.11 Those specimens that have not failed after more than 10 000 h may be included as failures to establish the regression line. Use of these data points may result in a lower or higher extrapolated strain. In either case the requirements of **9.14** must be satisfied.

NOTE 15—Non-failed specimens may be left under test and the regression line recalculated as failures are obtained.

9.12 Determine the final line for extrapolation to 50 years by the method of least squares given in **Annex A1**, using all end points along with those non-failure points selected by the method described in **9.11**. Calculate S_{xy} in accordance with **A1.4.2** and the coefficient of correlation, r , in accordance with **A1.4.3**.

9.13 If S_{xy} is greater than 0 (see **A1.4.2**), consider the data unsuitable.

9.14 If the coefficient of correlation value (see **A1.4.3**), r , is less than the applicable minimum value given in **Table A1.1** as a function of n , reject the data.

9.15 Prepare a graph on a log-log diagram in accordance with **9.12** showing time to failure versus strain, with time plotted on the horizontal (x) axis and strain plotted on the vertical (y) axis.

10. Reconfirmation of Strain Corrosion Regression Line

10.1 When a piping product has an existing strain corrosion regression line, any change in material, manufacturing process, construction, or liner will necessitate a screening evaluation as described in **10.2**, **10.3**, **10.4**, **10.5** and **10.6**.

10.2 Obtain failure points for at least two sets of specimens, each set consisting of three or more specimens tested at the same strain level, as follows:

Hours to Failure (Average of Set)	Failure Points
10 to 200	at least 3
More than 1000	at least 3
Total:	at least 6

Include as failures those specimens which have not failed after 3000 h provided they exceed the regression line.

10.3 Calculate and plot the 95 % confidence limits and the 95 % prediction limits of the original regression line in accordance with **A1.4.6** using only data obtained prior to the change.

NOTE 16—Prediction limits define the bounds for single observations, whereas confidence limits define the bounds for the regression line.

NOTE 17—For 95 % confidence limits, there is a 2.5 % probability that the mean value for the regression line may fall above the UCL and a 2.5 % probability that the mean value for the regression line may fall below the LCL. For 95 % prediction limits, there is a 2.5 % probability that individual data points may fall above the UPL and a 2.5 % probability that individual data points may fall below the LPL.

10.4 Consider any changes in material or manufacturing process minor and permissible if the results of **10.2** meet the following criteria.

10.4.1 The average time to failure for each strain level falls on or above the 95 % lower confidence limit of the original regression line.

10.4.2 The earliest individual failure time at each strain level falls on or above the 95 % lower prediction limit of the original regression line.

10.4.3 The failure points are distributed about the originally determined regression line. No more than two-thirds of the individual failure points may fall below the original regression line.

10.5 Alternatively to **10.4**, consider changes in material or manufacturing process permissible if the results of **10.2** meet the following:

10.5.1 All data points fall above the 95 % lower confidence limit of the original regression line, and

10.5.2 At least two points exceed 3000 h failure time.

10.6 Data meeting the criteria of **10.4** or **10.5** may be assumed to be part of the original data set and a new regression line determined using all failure points.

10.7 If the data fails to satisfy the criteria of **10.4** or **10.5**, the changes are considered major and a new regression line must be established. While the new test program is being conducted, an interim strain corrosion value for the material or process change may be taken as the lower of:

10.7.1 The 95 % lower confidence limit of the value obtained by extrapolating the failure points of **10.2** to 438 000 h (50 years) by the procedure in **9.10**.

10.7.2 The 95 % lower confidence limit of the original regression line at 50 years.

11. Report

11.1 The report shall include the following:

11.1.1 Complete identification of the pipe composition, manufacturer's code, size, and minimum wall thickness.

11.1.2 Test procedure used.

11.1.3 Data in **9.7**.

11.1.4 Notations of any type of distress observed in the specimens, whether it be discoloration, leakage, small fracture, surface crazing, or complete cracking, together with the time

and date of occurrence, and the location of distress. Indicate the location of distress using the bottom center as the reference point.

11.1.5 Complete description of the test solution (reagent).

11.1.6 Type of strain gage employed and method of mounting.

11.1.7 Temperature at which the test was run.

11.1.8 Graph of 9.15.

11.1.9 Strains at 50 years.

11.1.10 Coefficient of correlation, r (see 9.12).

12. Precision and Bias

12.1 No precision and bias statement can be made for this test method since controlled round-robin test programs have not been run. This test method is generally used to evaluate large-diameter fiberglass pipe.

13. Keywords

13.1 chemical resistance; constant deflection; extrapolation; fiberglass pipe; regression line; strain-corrosion

ANNEX

(Mandatory Information)

A1. LEAST SQUARES CALCULATION FOR LONG TERM STRAIN CORROSION VALUE

A1.1 General

A1.1.1 The analysis is based on the following relationship:

$$y = a + bx \quad (A1.1)$$

where:

y = one variable,

x = the other variable

b = the slope of the line, and

a = the intercept on the y axis.

A1.1.2 A linear functional relationship analysis (sometimes called “covariance analysis”) is used, subject to tests for the sign (that is, “+” or “-”) of the slope and the coefficient of correlation for the quantity of data available. The relevant equations are given together with example data and results, on the basis of which any other statistical computing package may be used subject to validation by agreement with the example results to within the indicated limits.

A1.1.3 For the purposes of this annex, a design service life of 50 years has been assumed.

A1.2 Procedure for Analysis of Data

A1.2.1 Use a linear functional relationship analysis to analyze n pairs of data values (as y and x) to obtain the following information:

A1.2.1.1 The slope of line, b ,

A1.2.1.2 The intercept on the y axis, a ,

A1.2.1.3 The correlation coefficient, r , and

A1.2.1.4 The predicted mean and the lower 95 % confidence and prediction intervals on the mean value.

A1.3 Assignment of Variables

A1.3.1 Let x be $\log_{10} t$, where t is the time, in hours, and let y be $\log_{10} V$, where V is the strain value.

A1.4 Functional Relationship Equations and Method of Calculation

A1.4.1 *Basic Statistics and Symbols:*

A1.4.1.1 The following basic statistics and symbols are used:

n = the number of pairs of observed data values (V_i, t_i),

y_i = the \log_{10} of V_i , where V_i is the strain at failure of observation i ; $i = 1, \dots, n$,

x_i = the \log_{10} of t_i , where t_i is the time to failure (in hours) of observation i ; $i = 1, \dots, n$,

\bar{y} = the arithmetic mean of all y_i values:

$$= \frac{1}{n} \sum y_i \quad (A1.2)$$

\bar{x} = the arithmetic mean of all x_i values:

$$= \frac{1}{n} \sum x_i \quad (A1.3)$$

A1.4.2 *Relevant Sums-of-Squares:*

A1.4.2.1 Calculate the following sums-of-squares and cross-products:

$$S_{xy} = \frac{1}{n} \sum (x_i - \bar{x})(y_i - \bar{y}) \quad (A1.4)$$

A1.4.2.2 If $S_{xy} > 0$, consider the data unsuitable for evaluating the material; otherwise, calculate also:

$$S_{xx} = \frac{1}{n} \sum (x_i - \bar{x})^2 \quad (A1.5)$$

$$S_{yy} = \frac{1}{n} \sum (y_i - \bar{y})^2 \quad (A1.6)$$

A1.4.3 *Correlation of Data:*

A1.4.3.1 Calculate the coefficient of correlation, r , from the following relationship:

$$r^2 = \frac{(S_{xy})^2}{(S_{xx} \times S_{yy})} \quad (A1.7)$$

$$r = \sqrt{r^2}$$

A1.4.3.2 If the value of r is less than the applicable minimum value given in Table A1.1 as a function of n , reject the data; otherwise, proceed to A1.4.4.

TABLE A1.1 Minimum Values for the Coefficient of Correlation, r , for Acceptable Data From n Pairs of Data

(n - 2)	r minimum	(n - 2)	r minimum
11	0.6835	25	0.4869
12	0.6614	30	0.4487
13	0.6411	35	0.4182
14	0.6226	40	0.3932
15	0.6055	45	0.3721
16	0.5897	50	0.3541
17	0.5751	60	0.3248
18	0.5614	70	0.3017
19	0.5487	80	0.2830
20	0.5386	90	0.2673
21	0.5252	100	0.2540
22	0.5145
23	0.5043
24	0.4952

A1.4.4 Functional Relationships:

A1.4.4.1 To find a and b for the functional relationship line, $y = a + bx$ (Eq A1.1), first set:

$$\lambda = \left(\frac{S_{xy}}{S_{xx}} \right) \tag{A1.8}$$

and then let:

$$b = -\sqrt{\lambda} \tag{A1.9}$$

and then:

$$a = \bar{y} - b\bar{x} \tag{A1.10}$$

NOTE A1.1—Since $y = \log_{10} V$ and $x = \log_{10} t$, hence $V = 10^y$, $t = 10^x$ and the implied relationship for V in terms of t is therefore:

$$V = 10^{(a+b \times \log_{10} t)}$$

A1.4.5 Calculation of Variances:

A1.4.5.1 If t_L is the applicable time to failure, then set:

$$x_L = \log_{10} t_L \tag{A1.11}$$

A1.4.5.2 Calculate, in turn, the following sequence of statistics. For $i = 1$ to $i = n$, the best fit, ξ_i , for true x , the best fit, Y_i , for true y and the error variance, σ_δ^2 , for x using (Eq A1.12), (Eq A1.13), and (Eq A1.14) respectively:

$$\xi_i = \{\lambda x_i + (y_i - a)b\} / 2\lambda \tag{A1.12}$$

$$Y_i = a + b\xi_i \tag{A1.13}$$

$$\sigma_\delta^2 = \left\{ \sum (y_i - Y_i)^2 + \lambda \sum (x_i - \xi_i)^2 \right\} / \{\lambda(n - 2)\} \tag{A1.14}$$

A1.4.5.3 Calculate the following quantities:

$$\tau = b\sigma_\delta / 2S_{xy} \tag{A1.15}$$

$$D = 2\lambda b\sigma_\delta^2 / nS_{xy} \tag{A1.16}$$

$$B = -D\bar{x}(1 + \tau) \tag{A1.17}$$

A1.4.5.4 Calculate the following variances: the variance, C , of b using the formula:

$$C = D(1 + \tau) \tag{A1.18}$$

the variance, A , of a using the formula:

$$A = D \left\{ \bar{x}^2 (1 + \tau) + \frac{S_{xy}}{b} \right\} \tag{A1.19}$$

the variance, σ_n^2 , of the fitted line at x_L using the formula:

$$\sigma_n^2 = A + 2Bx_L + Cx_L^2 \tag{A1.20}$$

the error variance, σ_ϵ^2 , for y using the formula:

$$\sigma_\epsilon^2 = 2\lambda\sigma_\delta^2 \tag{A1.21}$$

the total variance, σ_y^2 , for future values, y_L , for y at x_L using the formula:

$$\sigma_y^2 = \sigma_n^2 + \sigma_\epsilon^2 \tag{A1.22}$$

A1.4.5.5 Calculate the estimated standard deviation, σ_y , for y_L using the equation:

$$\sigma_y = (\sigma_n^2 + \sigma_\epsilon^2)^{0.5} \tag{A1.23}$$

and the predicted value, y_L , for y at x_L using the relationship:

$$y_L = a + bx_L \tag{A1.24}$$

where a and b have the values obtained in accordance with (Eq A1.9) and (Eq A1.10).

A1.4.6 Calculation and Confidence Intervals:

A1.4.6.1 Calculate the lower 95 % prediction interval, $y_{L,0.95}$, predicted for y_L using the equation:

$$y_{L,0.95} = y_L - t_v\sigma_y \tag{A1.25}$$

where:

- y_L = the value obtained in accordance with (Eq A1.24) when x_L is, as applicable, the value in accordance with (Eq A1.11) appropriate to a design life of, for example, 50 years (that is, $x_L = 5.6415$ (in h)) or to a time at which it is desired to predict with 95 % confidence the minimum value for the next observation of V ,
- σ_y = the value obtained in accordance with (Eq A1.23), and
- t_v = the applicable value for Student's t for $v = n - 2$ degrees of freedom, as given in Table A1.2 for a two sided 0.05 level of significance (that is, mean \pm 2.5 %).

TABLE A1.2 Student's "t" Value (Two-Sided 0.05 Level of Significance)

Degrees of Freedom (n - 2)	Student's "t" Value, t_v	Degrees of Freedom (n - 2)	Student's "t" Value, t_v	Degrees of Freedom (n - 2)	Student's "t" Value, t_v
1	12.7062	46	2.0129	91	1.9864
2	4.3027	47	2.0117	92	1.9861
3	3.1824	48	2.0106	93	1.9858
4	2.7764	49	2.0096	94	1.9855
5	2.5706	50	2.0086	95	1.9853
6	2.4469	51	2.0076	96	1.9850
7	2.3646	52	2.0066	97	1.9847
8	2.3060	53	2.0057	98	1.9845
9	2.2622	54	2.0049	99	1.9842
10	2.2281	55	2.0040	100	1.9840
11	2.2010	56	2.0032	102	1.9835
12	2.1788	57	2.0025	104	1.9830
13	2.1604	58	2.0017	106	1.9826
14	2.1448	59	2.0010	108	1.9822
15	2.1315	60	2.0003	110	1.9818
16	2.1199	61	1.9996	112	1.9814
17	2.1098	62	1.9990	114	1.9810
18	2.1009	63	1.9983	116	1.9806
19	2.0930	64	1.9977	118	1.9803
20	2.0860	65	1.9971	120	1.9799
21	2.0796	66	1.9966	122	1.9796
22	2.0739	67	1.9960	124	1.9793
23	2.0687	68	1.9955	126	1.9790
24	2.0639	69	1.9949	128	1.9787
25	2.0595	70	1.9944	130	1.9784
26	2.0555	71	1.9939	132	1.9781
27	2.0518	72	1.9935	134	1.9778

TABLE A1.2 *Continued*

Degrees of Freedom (n - 2)	Student's "t" Value, t _v	Degrees of Freedom (n - 2)	Student's "t" Value, t _v	Degrees of Freedom (n - 2)	Student's "t" Value, t _v
28	2.0484	73	1.9930	136	1.9776
29	2.0452	74	1.9925	138	1.9773
30	2.0423	75	1.9921	140	1.9771
31	2.0395	76	1.9917	142	1.9768
32	2.0369	77	1.9913	144	1.9766
33	2.0345	78	1.9908	146	1.9763
34	2.0322	79	1.9905	148	1.9761
35	2.0301	80	1.9901	150	1.9759
36	2.0281	81	1.9897	200	1.9719
37	2.0262	82	1.9893	300	1.9679
38	2.0244	83	1.9890	400	1.9659
39	2.0227	84	1.9886	500	1.9647
40	2.0211	85	1.9883	600	1.9639
41	2.0195	86	1.9879	700	1.9634
42	2.0181	87	1.9876	800	1.9629
43	2.0167	88	1.9873	900	1.9626
44	2.0154	89	1.9870	1000	1.9623
45	2.0141	90	1.9867	...	1.9600

TABLE A1.3 Example Data for Example Calculation

Data Point	Time, t	Strain, % v	Log Time, x	Log Strain, y
1	25.9	1.151	1.41330	0.06108
2	34.7	1.125	1.54033	0.05115
3	260.4	1.077	2.41564	0.03222
4	424.3	1.041	2.62767	0.01745
5	95.3	1.028	1.97909	0.01199
6	157.1	1.027	2.19618	0.01157
7	46.7	0.911	1.66932	-0.04048
8	124.7	0.902	2.09587	-0.04479
9	766.8	0.885	2.88468	-0.05306
10	1064	0.880	3.02694	-0.05552
11	1013	0.879	3.00561	-0.05601
12	2770	0.794	3.44248	-0.10018
13	12408	0.768	4.09370	-0.11464
14	4981	0.747	3.69732	-0.12668
15	3780	0.706	3.57749	-0.15120
16	4427	0.699	3.64611	-0.15552
17	28272	0.678	4.45136	-0.16877
18	16943	0.657	4.22899	-0.18244

A1.4.6.2 Calculate the corresponding lower 95 % prediction limit for V using the relationship:

$$V_{L\ 0.95} = 10^{Y_{L\ 0.95}} \quad (\text{A1.26})$$

A1.4.6.3 The predicted mean value of V at time t_L , that is, V_L , is given by the relationship:

$$V_L = 10Y_L \quad (\text{A1.27})$$

where:

Y_L = the value obtained in accordance with (Eq A1.24).

A1.4.6.4 Setting $\sigma_y^2 = \sigma_n^2$ in (Eq A1.22) will produce a confidence interval for the line rather than a prediction interval for a future observation.

A1.5 Example Calculation

A1.5.1 *Basic Data*—The example data given in Table A1.3, together with the example analysis given in this subsection, can be used to validate statistical packages or procedures. Because of rounding errors, it is unlikely that there will be exact agreement, but acceptable procedures should agree within $\pm 0.1\%$ of the results given in A1.5.6.

A1.5.2 *Sums of Squares*:

$$\begin{aligned} S_{xx} &= 0.8578342 \\ S_{yy} &= 5.878446 \times 10^{-3} \\ S_{xy} &= -0.064080 \end{aligned}$$

A1.5.3 *Coefficient of Correlation*:

$$r = 0.9023764$$

A1.5.4 *Functional Relationships*:

$$\begin{aligned} \lambda &= 6.852660 \times 10^{-3} \\ b &= -8.278079 \times 10^{-2} \\ a &= 0.1800067 \end{aligned}$$

A1.5.5 *Calculated Variances*:

$$\begin{aligned} D &= 9.266935 \times 10^{-5} \\ B &= -2.839595 \times 10^{-4} \\ C \text{ (variance of } b) &= 9.830865 \times 10^{-5} \\ A \text{ (variance of } a) &= 8.919367 \times 10^{-4} \\ \sigma_n^2 \text{ (error variance for } x) &= 8.168303 \times 10^{-4} \\ \sigma_\epsilon^2 \text{ (error variance for } y) &= 1.29122 \times 10^{-3} \end{aligned}$$

A1.5.6 *Confidence Limits*—For $N = 18$ and Student's t of 2.1199, the estimated mean and confidence and prediction intervals are given in Table A1.4.

TABLE A1.4 Confidence Limits

Time, h	Mean	Lower Confidence Interval	Lower Prediction Interval
1	1.51	1.31	1.20
10	1.25	1.13	1.04
100	1.03	0.97	0.86
1000	0.85	0.82	0.71
10 000	0.71	0.66	0.59
100 000	0.58	0.52	0.47
438 000	0.52	0.45	0.41

SUMMARY OF CHANGES

Committee D20 has identified the location of selected changes to this standard since the last issue (D3681 – 06) that may impact the use of this standard. (April 1, 2012)

- (1) Updated the ISO equivalency statement,
- (2) Improved the presentation relating to **Eq A1.9** in Annex A1 and,
- (3) Corrected a small error found in the data analysis Annex A1 **Eq A1.21** and as a result the example calculation in **A1.5**.

ASTM International takes no position respecting the validity of any patent rights asserted in connection with any item mentioned in this standard. Users of this standard are expressly advised that determination of the validity of any such patent rights, and the risk of infringement of such rights, are entirely their own responsibility.

This standard is subject to revision at any time by the responsible technical committee and must be reviewed every five years and if not revised, either reapproved or withdrawn. Your comments are invited either for revision of this standard or for additional standards and should be addressed to ASTM International Headquarters. Your comments will receive careful consideration at a meeting of the responsible technical committee, which you may attend. If you feel that your comments have not received a fair hearing you should make your views known to the ASTM Committee on Standards, at the address shown below.

This standard is copyrighted by ASTM International, 100 Barr Harbor Drive, PO Box C700, West Conshohocken, PA 19428-2959, United States. Individual reprints (single or multiple copies) of this standard may be obtained by contacting ASTM at the above address or at 610-832-9585 (phone), 610-832-9555 (fax), or service@astm.org (e-mail); or through the ASTM website (www.astm.org). Permission rights to photocopy the standard may also be secured from the Copyright Clearance Center, 222 Rosewood Drive, Danvers, MA 01923, Tel: (978) 646-2600; <http://www.copyright.com/>