



Designation: D365 – 01 (Reapproved 2017)

## Standard Guide for Soluble Nitrocellulose Base Solutions<sup>1</sup>

This standard is issued under the fixed designation D365; the number immediately following the designation indicates the year of original adoption or, in the case of revision, the year of last revision. A number in parentheses indicates the year of last reapproval. A superscript epsilon ( $\epsilon$ ) indicates an editorial change since the last revision or reapproval.

### 1. Scope

1.1 This guide covers the testing of soluble nitrocellulose base solutions that are made by dispersing various kinds and concentrations of soluble nitrocellulose (cellulose nitrate) in various solvent mixtures.

1.2 The values stated in SI units are to be regarded as the standard. The values given in parentheses are for information only.

1.3 *This standard does not purport to address all of the safety concerns, if any, associated with its use. It is the responsibility of the user of this standard to establish appropriate safety and health practices and determine the applicability of regulatory limitations prior to use.* For specific hazard statements see Section 11.

1.4 *This international standard was developed in accordance with internationally recognized principles on standardization established in the Decision on Principles for the Development of International Standards, Guides and Recommendations issued by the World Trade Organization Technical Barriers to Trade (TBT) Committee.*

### 2. Referenced Documents

2.1 *ASTM Standards:*<sup>2</sup>

D301 Test Methods for Soluble Cellulose Nitrate (Withdrawn 2011)<sup>3</sup>

D333 Guide for Clear and Pigmented Lacquers

D1193 Specification for Reagent Water

D1200 Test Method for Viscosity by Ford Viscosity Cup

E300 Practice for Sampling Industrial Chemicals

### 3. Significance and Use

3.1 Since the desired specifications and compositions of soluble nitrocellulose base solutions vary greatly, these meth-

<sup>1</sup> This guide is under the jurisdiction of ASTM Committee D01 on Paint and Related Coatings, Materials, and Applications and is the direct responsibility of Subcommittee D01.55 on Factory Applied Coatings on Preformed Products.

Current edition approved June 1, 2017. Published June 2017. Originally approved in 1933. Last previous edition approved in 2011 as D365 – 01 (2011). DOI: 10.1520/D0365-01R17.

<sup>2</sup> For referenced ASTM standards, visit the ASTM website, www.astm.org, or contact ASTM Customer Service at service@astm.org. For *Annual Book of ASTM Standards* volume information, refer to the standard's Document Summary page on the ASTM website.

<sup>3</sup> The last approved version of this historical standard is referenced on www.astm.org.

ods are used to establish whether limits that shall be as agreed upon between the producer and the user have been met.

### 4. Sampling

4.1 Select the sampling method from those listed in Practice E300.

### CONSISTENCY (VISCOSITY)

### 5. Consistency Tests

5.1 *For Consistencies from 3 to 500 s*—Determine the consistency by falling-ball consistency test described in Test Methods D301 for those solutions having a consistency from 3 to 500 s when tested in that apparatus.

5.2 *For Consistencies Less than 3 s*—Determine the consistency by Test Method D1200 for those solutions having a consistency of less than 3 s when tested in the falling-ball apparatus referred to in 5.1.

5.3 *For Consistencies over 500 s*—Determine the consistency using the apparatus and procedure described in Sections 6 and 7 for those solutions having a consistency greater than 500 s when tested in the falling-ball apparatus referred to in 5.1.

### 6. Apparatus

6.1 The consistency test apparatus, shown in Fig. 1, shall consist of the following:

6.1.1 *Glass Tube* (preferably heat-resistant glass),<sup>4</sup>  $50 \pm 1.5$  mm ( $2 \pm 1/32$  in.) in inside diameter and 255 mm (10 in.) in length, with marks  $177 \pm 1$  mm ( $5 \pm 1/16$  in.) apart, the upper one being 75 mm (3 in.) from the top of the tube.

NOTE 1—The steel ball can be removed (in order to leave the same material in the tube for a check run) by removing the lower stopper. However, a small air bubble is usually introduced in this way. It is preferable to invert the tube, removing the guide to get the ball out. It is often necessary to put a few drops of solvent in the guide lip to loosen it from the tube on account of the solution drying at the edge of the tube. When the latter method is used for removing the ball, a larger bubble traverses the tube than when the former method is used, but a large bubble moves sufficiently fast, even in a very viscous solution, to escape at the top in a few minutes, whereas small bubbles take hours to escape.

<sup>4</sup> Borosilicate glass is satisfactory for this purpose.

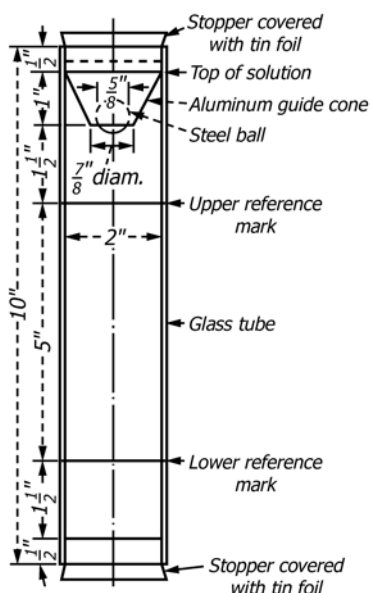

FIG. 1 Apparatus for Consistency (Viscosity) Test of Solutions Having Consistencies over 500 s

6.1.2 *Steel Ball*,  $15.88 \pm 0.02$  mm ( $0.625 \pm 0.001$  in.) in diameter, and weighing  $16.536 \pm 0.10$  g.

6.1.3 *Aluminum Guide Cone* of light gage aluminum (approximately 0.5 mm (0.02 in.) in thickness) as shown in Fig. 1. The orifice of the guide cone shall be 22 mm ( $7/8$  in.) in diameter, the conical portion 25 mm (1 in.) in height, the cylindrical portion 12.7 mm ( $1/2$  in.) in height, and the outside diameter shall be slightly under 50 mm (2 in.) so as to fit snugly into the viscosity tube.

6.1.4 *Stoppers*, made preferably of rubber and covered with tin foil.

## 7. Procedure

7.1 Fill the tube in any convenient manner whereby bubbles do not form and no appreciable amount of solvent is lost. One method is to immerse the lower end of the open tube in the solution and to apply suction at the upper end of the tube. In this manner the tube can be filled in from 5 to 10 s without the introduction of air bubbles or an appreciable loss of solvent. Close the bottom of the tube with a stopper covered with tin foil. Push the aluminum guide cone slowly into the top of the tube and insert a stopper covered with tin foil into the top of the guide.

7.2 Bring the tube and its contents to a temperature of  $25 \pm 0.1^\circ\text{C}$  by placing in a suitable bath. Allow at least 30 min for the solution to reach temperature equilibrium. For accurate measurements keep the tube during the determination either in a thermostat or suspended within a considerably larger cylinder of water at the specified temperature.

7.3 Remove the upper stopper only long enough to place the ball in the center of the tube; this can be done conveniently with crucible tongs. The principal value of the guide cone is to retard the ball sufficiently at the start of its fall so that the solution will close over the ball and not leave on the top of the ball a large "trailer bubble." If the guide is not used a big trailer

bubble usually accompanies the ball, retarding its fall and, if the bubble is off center on the ball, pulling the latter away from the center of the tube.

7.4 Measure the time of fall in seconds from the instant the bottom of the ball is level with the upper reference mark on the tube until it reaches the lower mark on the tube.

## NONVOLATILE MATTER

### 8. Procedure

8.1 Determine the percent of nonvolatile matter in accordance with the procedure described in the Nonvolatile Matter section of Test Methods D333.

## APPEARANCE OF SOLUTION

### 9. Procedure

9.1 Compare the appearance of the soluble nitrocellulose base solution with a reference standard agreed upon between the purchaser and the seller (both the reference standard and sample solutions shall be thoroughly agitated before making observations) in similar bottles for turbidity, hair, grain, and insoluble matter.

## DEPTH OF COLOR

### 10. Apparatus

10.1 The apparatus used for the preparation of the color standards and for the depth of color determinations shall consist of the following:

10.1.1 *Light*—Source of transmitted light.

NOTE 2—Not absolutely necessary but will increase accuracy and be more convenient.

10.1.2 *Bottles*, three dozen 60 mL (2-oz L) screw-cap, square, glass.

10.1.3 *Flasks*, several, 1-L, volumetric.

10.1.4 *Burets*, two, 50-mL.

10.1.5 *Analytical Balance*.

10.1.6 *Colorimeter*—Dubosq colorimeter (see Note 2).

10.1.7 *Color Glass*—Yellow glass about 25 mm square and 10 mm thick.<sup>5</sup>

### 11. Reagents and Materials

11.1 *Purity of Reagents*—Reagent grade chemicals shall be used in all tests. Unless otherwise indicated, it is intended that all reagents shall conform to the specifications of the Committee on Analytical Reagents of the American Chemical Society, where such specifications are available.<sup>6</sup> Other grades may be

<sup>5</sup> The sole source of supply of color glass, signal yellow No. 330, known to the committee at this time is Corning Glass Works, Corning, NY. If you are aware of alternative suppliers, please provide this information to ASTM International Headquarters. Your comments will receive careful consideration at a meeting of the responsible technical committee,<sup>1</sup> which you may attend.

<sup>6</sup> *Reagent Chemicals, American Chemical Society Specifications*, American Chemical Society, Washington, DC. For suggestions on the testing of reagents not listed by the American Chemical Society, see *Analar Standards for Laboratory Chemicals*, BDH Ltd., Poole, Dorset, U.K., and the *United States Pharmacopeia and National Formulary*, U.S. Pharmacopeial Convention, Inc. (USPC), Rockville, MD.

**TABLE 1 Platinum-Cobalt Color Standards**

Platinum-Cobalt Color Standards	Quantity of No. 10 Color Standard, mL	Quantity of Distilled Water, mL
No. 1	5	45
No. 2	10	40
No. 3	15	35
No. 4	20	30
No. 5	25	25
No. 6	30	20
No. 7	35	15
No. 8	40	10
No. 9	45	5
No. 10	50	0

**TABLE 2 Caramel Color Standards**

Caramel Color Standards	Quantity of No. 500 Caramel Color Standard, mL	Quantity of Distilled Water plus Phenol, mL
No. 12	1.2	48.8
No. 15	1.5	48.5
No. 20	2.0	48.0
No. 25	2.5	47.5
No. 30	3.0	47.0
No. 35	3.5	46.5
No. 40	4.0	46.0
No. 45	4.5	45.5
No. 50	5.0	45.0
No. 60	6.0	44.0
No. 70	7.0	43.0
No. 75	7.5	42.5
No. 80	8.0	42.0
No. 90	9.0	41.0
No. 100	10.0	40.0
No. 125	12.5	37.5
No. 150	15.0	35.0
No. 175	17.5	32.5
No. 200	20.0	30.0
No. 250	25.0	25.0
No. 300	30.0	20.0
No. 350	35.0	15.0
No. 400	40.0	10.0
No. 450	45.0	5.0
No. 500	50.0	0.0

used, provided it is first ascertained that the reagent is of sufficiently high purity to permit its use without lessening the accuracy of the determination.

11.2 *Purity of Water*—Unless otherwise indicated, references to water shall be understood to mean reagent water as defined by Type III of Specification **D1193**.

11.3 *Potassium Chloroplatinate*, ( $K_2PtCl_6$ ). **Warning:** This material is hazardous. Carefully review Material Safety Data Sheets supplied by manufacturers for handling and first aid instruction.

11.4 *Cobalt Chloride* ( $CoCl_2 \cdot 6H_2O$ ). (**Warning**—See **11.3**.)

11.5 *Hydrochloric Acid* (*sp gr 1.19*)—Concentrated hydrochloric acid (HCl). (**Warning**—See **11.3**.)

11.6 *Caramel* (sugar coloring).

11.7 *Phenol*. (**Warning**—See **11.3**.)

## 12. Preparation of Color Standards

12.1 *Platinum-Cobalt Color Standards*—Prepare the platinum-cobalt color standards as follows: Weigh out on an

analytical balance exactly 1.245 g of  $K_2PtCl_6$  and 1.000 g of crystallized cobalt chloride ( $CoCl_2 \cdot 6H_2O$ ). Dissolve in distilled water, add 100 mL of HCl (*sp gr 1.19*), and dilute to 1000 mL with distilled water. This solution is color standard No. 10.<sup>7</sup> Prepare color standards Nos. 1 to 10, inclusive, by accurately measuring from burets directly into the square 2-oz (60-mL) bottles the quantities shown in **Table 1** of the No. 10 color standard and distilled water. After preparation of the color standards seal the bottles with corks and paraffin before putting on the screw caps. The platinum-cobalt color standards are permanent for approximately six months. Make the color standards from No. 12 to No. 500, inclusive, from a caramel solution, but the color is based on the platinum-cobalt color standard.

12.2 *Caramel Color Standards*—Prepare the caramel color standards as follows: Dilute caramel (sugar coloring) in the ratio of about 1 mL of caramel to 100 mL of distilled water in a glass vessel. Add 0.5 % phenol and agitate thoroughly. Adjust the concentration of this solution so that when it is diluted in the ratio of 1 mL of solution to 49 mL of distilled water, to which has been added 0.5 % phenol, the solution will match color No. 10 of the platinum-cobalt color standard. This caramel solution before dilution is color No. 500 (**Note 3**). Prepare color standards No. 12 to No. 500, inclusive, by accurately measuring from burets directly into the square 2-oz (60-mL) bottles the quantities shown in **Table 2** of color No. 500 caramel standard and distilled water to which has been added 0.5 % phenol. After preparation of the color standards, seal the bottles with corks and paraffin before putting on the screw caps. All of the caramel color standards are permanent for approximately one month but should be checked semi-monthly if frequently used.

**NOTE 3**—It is more convenient to check the caramel color standard No. 500 against a colored glass that has been previously standardized against the platinum-cobalt color standard; a piece of signal yellow glass (see **10.1.7**) about 25 mm square by 10 mm thick may be standardized and used as a check on the caramel solution. This must be done by use of a colorimeter.

## 13. Procedure

13.1 Fill a square 60-mL (2-oz) glass bottle with the material to be tested and match this against one of the color standards using either direct daylight or indirect artificial transmitted light, the latter being preferred. The number of the color standard matched is the depth of color of the material.

## 14. Precision and Bias

14.1 The precision and bias of these test methods is as described for each of the separate methods cited if available.

## 15. Keywords

15.1 appearance; consistency testing; depth of color; non-volatile matter; soluble nitrocellulose base solutions

<sup>7</sup> This solution has an assigned value of 500 on the Hazen color scale (see *American Chemical Journal*, Vol XIV, p. 300).

*ASTM International takes no position respecting the validity of any patent rights asserted in connection with any item mentioned in this standard. Users of this standard are expressly advised that determination of the validity of any such patent rights, and the risk of infringement of such rights, are entirely their own responsibility.*

*This standard is subject to revision at any time by the responsible technical committee and must be reviewed every five years and if not revised, either reapproved or withdrawn. Your comments are invited either for revision of this standard or for additional standards and should be addressed to ASTM International Headquarters. Your comments will receive careful consideration at a meeting of the responsible technical committee, which you may attend. If you feel that your comments have not received a fair hearing you should make your views known to the ASTM Committee on Standards, at the address shown below.*

*This standard is copyrighted by ASTM International, 100 Barr Harbor Drive, PO Box C700, West Conshohocken, PA 19428-2959, United States. Individual reprints (single or multiple copies) of this standard may be obtained by contacting ASTM at the above address or at 610-832-9585 (phone), 610-832-9555 (fax), or [service@astm.org](mailto:service@astm.org) (e-mail); or through the ASTM website ([www.astm.org](http://www.astm.org)). Permission rights to photocopy the standard may also be secured from the Copyright Clearance Center, 222 Rosewood Drive, Danvers, MA 01923, Tel: (978) 646-2600; <http://www.copyright.com/>*