



Standard Test Methods for Evaporation Rates of Volatile Liquids by Shell Thin-Film Evaporometer¹

This standard is issued under the fixed designation D3539; the number immediately following the designation indicates the year of original adoption or, in the case of revision, the year of last revision. A number in parentheses indicates the year of last reapproval. A superscript epsilon (ϵ) indicates an editorial change since the last revision or reapproval.

This standard has been approved for use by agencies of the U.S. Department of Defense.

1. Scope

1.1 These test methods cover the determination of the rate of evaporation of volatile liquids of low viscosity using the Shell thin-film evaporometer. These test methods have been applied to a wide range of volatile liquids, including paint, varnish, and lacquer solvents and thinners to various hydrocarbons and to insecticide spray-base oils.

1.2 The test methods for the determination of evaporation rate using the thin-film evaporometer are:

	Sections
Test Method A ^{2,3} —Manual Recording	5 – 11
Test Method B—Automatic Recording	12 – 17

1.3 These test methods are limited only by the viscosity of the volatile liquid which must be sufficiently low to permit the dispensing of an accurately measured specimen from a syringe.

1.4 The values stated in SI units are to be regarded as the standard. The values given in parentheses are for information only.

1.5 *This standard does not purport to address all of the safety concerns, if any, associated with its use. It is the responsibility of the user of this standard to establish appropriate safety and health practices and determine the applicability of regulatory limitations prior to use.* Specific hazard statements are given in 5.2 and 5.6.

¹ These test methods are under the jurisdiction of ASTM Committee D01 on Paint and Related Coatings, Materials, and Applications and are the direct responsibility of Subcommittee D01.24 on Physical Properties of Liquid Paints and Paint Materials.

Current edition approved Feb. 1, 2011. Published March 2011. Originally approved in 1976. Last previous edition approved in 2004 as D3539 – 87 (2004). DOI: 10.1520/D3539-11.

² These test methods are essentially the same as the one developed by the New York Society for Paint Technology. The Precision section was added by ASTM Subcommittee D01.24 and is based upon the data of the New York Society for Paint Technology.

³ See “Comparative Evaporation Rates of Solvents: II,” New York Club, Technical Subcommittee No. 66, *Official Digest*, 28, No. 382, 1956, p. 1060.

2. Referenced Documents

2.1 *ASTM Standards*:⁴

D891 Test Methods for Specific Gravity, Apparent, of Liquid Industrial Chemicals

E1 Specification for ASTM Liquid-in-Glass Thermometers

3. Summary of Test Methods

3.1 A known volume of liquid is spread on a known area of filter paper that is suspended from a sensitive balance in a cabinet. Dried air or nitrogen at 25°C is passed through the cabinet at a known rate. The loss of weight of the filter paper/liquid is determined and plotted against time.

4. Significance and Use

4.1 The rate of evaporation of volatile liquids from a solution or dispersion is important because it affects the rate of deposition of a film and flow during deposition, and thereby controls the structure and appearance of the film. In the formulation of paints and related products, solvents are chosen based on the evaporation characteristics appropriate to the application technique and the curing temperature.

TEST METHOD A—EVAPORATION RATE USING THE MANUAL THIN-FILM EVAPOROMETER

5. Apparatus

5.1 *Evaporometer*, thin-film evaporometer⁵ as shown in Fig. 1 (see Annex A1).

5.2 *Constant-Temperature Cabinet* for evaporometer. (**Warning**—In instances with the solvents and other volatile materials normally tested using this apparatus and under the conditions specified in this test method, the concentration of

⁴ For referenced ASTM standards, visit the ASTM website, www.astm.org, or contact ASTM Customer Service at service@astm.org. For *Annual Book of ASTM Standards* volume information, refer to the standard's Document Summary page on the ASTM website.

⁵ The manual Shell thin-film evaporometer is no longer available.

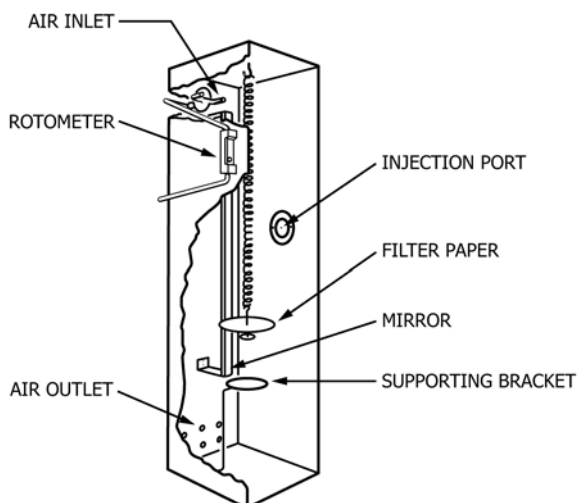

FIG. 1 Details of the Thin-Film Evaporometer

solvent or other flammable material being exhausted into the laboratory atmosphere will be significantly below any concentration that could be hazardous, that is, a lower flammable limit. However, it may be desirable to locate the instrument and cabinet in a laboratory exhaust hood if the routine handling of certain materials may present a hazard due to toxicity, extreme volatility, or flammability.)

5.3 *Interval Timer: Stopwatch or Electric Timer*—A timer that gives an audible signal at 10 or 20-s intervals and that gives a warning signal approximately 3 s before the end of the interval is preferred.

5.4 *Filter Paper Disk*—Fast, open-textured filter paper, 90 mm in diameter, with a circle approximately 60 mm in diameter (and concentric with the edge) lightly drawn on the paper with a pencil.

5.5 *Syringe*—A 1.00-mL hypodermic syringe equipped with a 225-mm needle of 1.3-mm outside diameter stainless steel tubing.⁶ Due to manufacturing variations, the syringe should be calibrated before use.

5.6 *Dehumidification Equipment*—A suggested setup is given in a schematic diagram, Fig. 2. (**Warning**—Use of this dehumidification apparatus requires the safety practices relative to the handling, use, and disposal of hazardous acids and caustics be observed. When handling these materials, protective eye or face shields, or both, and protective clothing are recommended.)

5.7 *Hygrometer (or other humidity-sensing device)*, capable of indicating low humidities.

5.8 *Thermometers*, of suitable accuracy such as ASTM Bomb Calorimeter thermometer 56C having a range from 19 to 35°C, subdivisions 0.02°C or Thermometer 56F (66 to 95°F with 0.05°F subdivisions), and conforming to the requirements of Specification E1. In addition, temperature measuring de-

vices that do not contain mercury such as liquid-in-glass thermometers, thermocouples, or platinum resistance thermometers that provide equivalent or better accuracy and precision and cover the temperature range for thermometers 56C or 56F may be used.

6. Preparation of Evaporometer

6.1 Place the filter paper disk on the wire support, threading the hook through a small hole in the center of the paper. Attach the hook to the steel spring below the sighting disk and allow the paper and the paper support to hang therefrom.

6.2 Close the evaporometer and cabinet doors and allow the temperature in both chambers and the humidity to equilibrate at the following test conditions:

Cabinet and evaporation temperature: $25 \pm 0.25^\circ\text{C}$ ($77 \pm 0.5^\circ\text{F}$)
Evaporometer humidity: 0 to 5 % relative humidity

Approximately 2 h are required for the humidity to drop to less than 5 %.

6.3 Adjust the air flow to 21 L/min (center of ball float opposite correct mark on the rotometer scale).

7. Conditioning

7.1 Bring the sample or a portion of it to an equilibrium temperature of $25 \pm 0.5^\circ\text{C}$ ($77 \pm 1.0^\circ\text{F}$) in a constant-temperature bath. Determine the specific gravity of the sample at this temperature in accordance with Test Methods D891.

8. Procedure

8.1 Record the position of the filter paper as indicated by alignment of the sighting disk with its mirror image. This is the no-load position.

8.2 Raise the wire mesh bracket until the bottom of the disk support rests lightly on it.

8.3 Withdraw into the syringe 0.70 mL of the solvent which is at $25 \pm 0.5^\circ\text{C}$ ($77 \pm 1.0^\circ\text{F}$). Make certain that all air bubbles are expelled from the syringe and the needle before application of the specimen to the filter paper.

8.4 Insert the hypodermic needle into the small opening on the right-hand side of the instrument and position the needle tip so that it almost touches the disk and is just over the line that was drawn.

8.5 Start applying the solvent to the disk. As the first drop hits the disk, start the timer. The solvent should be applied at a uniform rate in ± 2 s and as evenly as possible along the drawn line. To ensure consistent specimen size, touch the tip of the hypodermic needle to the filter paper to dispense the last drop of solvent.

8.6 Immediately lower the wire mesh bracket away from the disk support. Obtain the first reading of the position of the sighting disk at 40 s and then every 20 s. Record the time and the scale reading on the report form. A sample report form is shown in Annex A2.

NOTE 1—With very slow evaporating solvents, it is not necessary to take readings as often as every 20 s. The operator can determine a suitable time interval after the first 200 s.

⁶ Syringe: Becton, Dickinson and Co., No. 1YT available from Fisher Scientific Co. Needle: Special Syringe Needle Type LNR, 18-gage, 9-in. long blunt round end, no bevel available on special order from Becton, Dickinson and Co. through Fisher Scientific Co., 711 Forbes Ave., Pittsburgh, PA 15239.

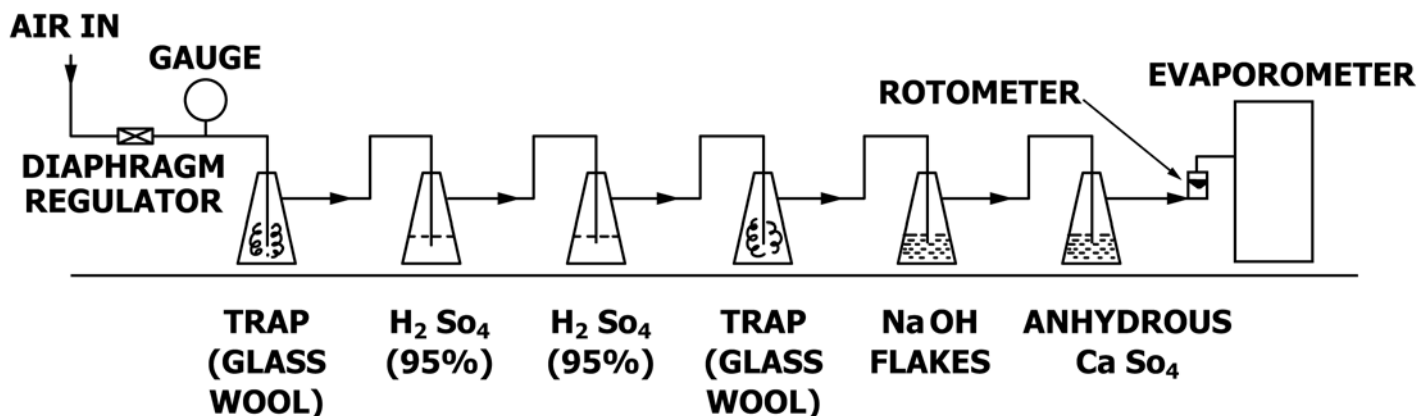

NOTE 1—One-litre flasks should be used throughout.

FIG. 2 Diagram of Dehumidification Apparatus

8.7 Stop the timer when the sighting disk has returned to the original unloaded position.

NOTE 2—The filter paper may be reused provided the solvent leaves no appreciable residue in evaporating.

9. Calculation

9.1 Calculate the evaporation rate as follows:

$$ER = \frac{C}{S} \times 100(B - Z) \quad (1)$$

where:

$S = V \times D$ and $Z = N - (S/C)$

$ER =$ evaporation rate, wt %,

$C =$ spring constant, cm/g elongation,

$S =$ specimen weight,

$V =$ 0.70-mL aliquot volatile liquid at $25 \pm 0.5^\circ\text{C}$ ($77 \pm 1.0^\circ\text{F}$),

$D =$ density of volatile liquid at $25 \pm 0.5^\circ\text{C}$ ($77 \pm 1.0^\circ\text{F}$) (Taken as equivalent to specific gravity but with units of mL/g)

$B =$ scale reading taken during evaporation of aliquot,

$Z =$ zero percent evaporated, scale reading = $N - (S/C)$, and

$N =$ no-load scale reading (100 % evaporated reading).

9.2 Plot the percent evaporated against elapsed time in seconds and draw a smooth curve through the points. From the curve, determine at 10 weight % increments to 90 % and for 95 and 100 % evaporation the time in seconds to the nearest value as follows:

Approximate Elapsed Time to 100 % Evaporated Point, s	Report to Nearest Indicated Value, s
Less than 300	1
300 to 600	5
600 to 1800	10
1800 to 3600	30
3600 to 7200	60
More than 7200	nearest 2 % of indicated value

NOTE 3—The curve drawn through the various points should pass

through zero or the origin. If it passes to the right of the origin, the delivery time was in excess of 12 s or an aliquot larger than that specified was delivered. If it passes to the left of the origin, then the aliquot was smaller than specified.

10. Report

10.1 Report the elapsed time in seconds at 10 weight % intervals through 90 % and for 95 and 100 % evaporation, and the relative evaporation rate (*n*-butyl acetate = 1.0). Relative evaporation rate is calculated from the 90 weight % evaporated times for the test solvent and for *n*-butyl acetate (99 % ester).

11. Precision⁷

11.1 On the basis of an interlaboratory study of the test method in which operators in six laboratories determined the 90 % evaporation point of six solvents covering a broad range in evaporation rate, the between-laboratories coefficient of variation was found to be 6.3 % relative at 24 df after discarding two divergent values. On the basis of the results obtained by three laboratories on three of the solvents having 90 % evaporated times of 200 to 600 s, the within-laboratory coefficient of variation was found to be 0.83 % relative at 18 df. Based on these coefficients, the following criteria should be used for judging the acceptability of results at the 95 % confidence level:

11.1.1 *Repeatability*—For solvents with 90 % evaporation times of 200 to 600 s, two results, each the mean of two determinations, obtained by the same operator on different days should be considered suspect if they differ by more than 2.5 %.

11.1.2 *Reproducibility*—Two results, each the mean of two determinations, obtained by operators in different laboratories should be considered suspect if they differ by more than 18.2 %.

⁷ Supporting data have been filed at ASTM International Headquarters and may be obtained by requesting Research Report RR:D01-1003. Contact ASTM Customer Service at service@astm.org.

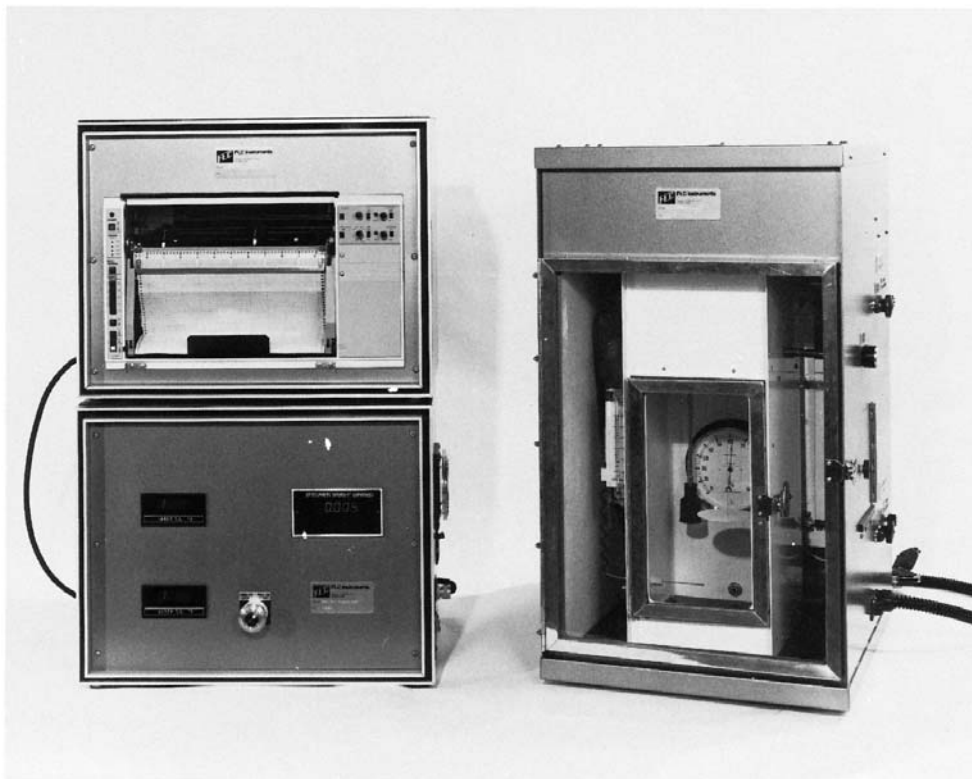

FIG. 3 Automatic Thin-Film Evaporometer

TEST METHOD B—EVAPORATION RATE USING THIN-FILM EVAPOROMETER, AUTOMATIC RECORDING

12. Apparatus

12.1 *Evaporometer*, automatic thin-film evaporometer,⁸ as shown in Fig. 3.

12.2 *Filter Paper Disk*—See 5.4.

12.3 *Syringe*—See 5.5.

12.4 *Dehumidification Equipment*—See 5.6.

12.5 *Strip Chart Recorder*—Any strip chart recorder capable of recording the output signal (0 to 15 mA) from the electronic optical weight-sensing device. The recorder should provide a range of chart speeds including 6.3 to 50 mm (¼ to 2 in.)/min. It is also desirable for the recorder to accommodate 2 or more mA ranges in order to regulate the sensitivity of measurement.

13. Preparation of Evaporometer

13.1 Place the filter paper disk on the wire frame threading the hook through a small hole in the center of the paper. Attach the wire frame to the support hook in the evaporometer.

13.2 Close the evaporometer and cabinet doors and equilibrate both chambers as in 6.2.

13.3 Adjust the air flow to 21 min/L.

14. Conditioning of Sample

14.1 See 7.1.

15. Procedure

15.1 When all components (including the filter paper in place) are at equilibrium, adjust the recording pen to a prominent “zero” position near the edge of the chart on the recorder; then turn the switch for the chart motor to the OFF position. This constitutes the “zero” load and time position for the test.

NOTE 4—The milliamperage range and chart speed should be selected, if possible, so that the dimensions of the weight and time axes of the plotted curve are approximately the same length.

15.2 Measure 0.70 mL of test sample into the hypodermic syringe (see 8.3).

15.3 Open the small side door on the right-hand side of the insulating cabinet and insert the hypodermic needle through the rubber porthole until the needle tip almost touches the disk and is just over the penciled line.

NOTE 5—Care must be exercised to avoid depressing the plunger of the syringe during this operation. Otherwise the solvent will be accidentally and prematurely dispensed onto the paper before the strip chart recorder is started.

15.4 When all is ready turn the strip chart motor switch to the ON position and simultaneously start distribution of the specimen onto the filter paper. The complete specimen should be dispensed uniformly in 10 ± 2 s along the line. The recorder

⁸ The automatic Shell thin-film evaporometer, Apparatus Catalog No. F1522 is available from the Falex Corporation, Inc., 1020 Airpark Drive, Sugar Grove, IL 60554-9585, www.falex.com.

pen will “advance” immediately to an “apex” position equivalent to the total weight of the specimen, less that portion that evaporated during the application period. The pen will gradually return to its original position as the solvent evaporates and the chart advances. The evaporation is complete when the recording pen has returned to its original “no-load” position.

NOTE 6—It is common for the final portion of the curve to exhibit a “tailing-off.” This is due to artifacts of the method such as (1) hydrogen bonding of the last traces of solvent with the cellulose fibers of the filter paper and (2) a gradual diminution of the area of the filter paper wet by solvent (that is, in the final stage of evaporation, drying of the paper progresses from the outer edge toward the center of the disk). Thus, it is common practice for the evaporation cycle to be considered “complete” when the recording pen returns to 99.5 % of the original displacement.

16. Calculations and Reporting

16.1 Determine the evaporation time in seconds at 10 weight % increments to 90 %, and for 95 to 100 % from the evaporation curve as follows:

16.1.1 Divide the theoretical recording pen displacement for the total specimen into ten equal units along the weight axis of the evaporation curve; then project the established 10 % divisions to corresponding intersecting points on the evaporation curve. The 0 % evaporated or full-load point at zero time can be obtained either by extrapolation of the evaporation curve back to zero evaporation time or calculation using the weight of the sample and the calibration data for the instrument (see [Annex A3](#)). The routine calculation of the 0 % evaporated, full-load point is recommended as a check for correct specimen size.

16.1.2 Multiply the distance along the time axis from the zero starting time by the chart speed factor in seconds giving the total elapsed time for each defined point along the curve. For example, at a chart speed of 1 in./min and a 20 % evaporation point at 3.30 in. the evaporation time is 198 s ($60 \times 3.30 = 198$). Use the procedure given in [9.2](#) to round results.

16.2 An alternative method of reporting evaporation results is to express an area evaporation rate in terms of grams evaporated per second per square centimetre of evaporating surface. This method is not exact because the evaporation rate is not linear throughout the complete evaporation period, but it is a useful approximation to represent the general volatility of a solvent. The calculation of evaporation rate is as follows:

$$\text{Area evaporation rate, } R = \frac{C \times D}{A - B} \times 10^8 \quad (2)$$

where:

R = evaporation rate, $\text{cm}^2/\text{s} \times 10^8$,

C = a factor = $0.00438 \text{ mL}/\text{cm}^2$ obtained from:

0.70 mL	= specimen size,
0.80	= increment between the 10 % and 90 % evaporation points (the first and last 10 % increment are disregarded),
128 cm^2	= total evaporating surface of 90-mm diameter filter paper,

$$\text{then } C = \frac{0.70 \times 0.80}{128} = 0.00438 \text{ mL}/\text{cm}^2$$

D = specific gravity of the solvent at 25°C (77°F),

A = 90 % evaporation time, s, and

B = 10 % evaporation time, s.

The multiplicand, 10^8 , is inserted in the equation to avoid decimal fractions.

17. Precision ⁷

17.1 On the basis of an interlaboratory study of the test method in which operators in four laboratories determined the 90 % evaporation point of seven solvents covering a broad range in evaporation rate, the within-laboratory coefficient of variation was found to be 1.78 % relative at 35 df and the between-laboratories coefficient of variation was found to be 3.88 % relative at 28 df. Based on these coefficients, the following criteria should be used for judging the acceptability of results at the 95 % confidence level:

17.1.1 *Repeatability*—Two results, each the mean of two determinations, obtained by the same operator on different days should be considered suspect if they differ by more than 5.1 %.

17.1.2 *Reproducibility*—Two results, each the mean of two determinations, obtained by operators in different laboratories should be considered suspect if they differ by more than 11.25 %.

18. Keywords

18.1 evaporation rate; evaporation rates of solvents; shell thin-film evaporometer

ANNEXES

(Mandatory Information)

A1. CALIBRATION OF THE THIN-FILM EVAPOROMETER, MANUAL RECORDING

A1.1 Remove the filter from its wire support and replace it with a small piece of aluminum foil, about 50 by 50 mm; then again suspend the support from the coil spring. Record the position of the sighting disk. Load the spring by placing a 1-g analytical balance weight onto the aluminum foil and again record the elongation of the spring. Thus, the spring constant, C , in grams per centimetre, is equal to 1.000 g divided by the elongation in centimetres.

A1.2 *Standardization of the Evaporometer*—Since there may be slight variations in manufacture, the evaporometer should be standardized prior to routine usage. The standard solvent, *n*-butyl acetate, (99 % ester), should have a 90 % evaporation time of 470 ± 10 s under the prescribed test conditions. If the evaporation time is outside these limits, a slight increase or decrease of the air flow should be sufficient to bring about the desired results.

A2. SAMPLE EVAPORATION RATE REPORT FORM

A2.1 A sample evaporation rate report form is shown in Table A2.1.

TABLE A2.1 Evaporation Rate Report Form

No. _____ Specimen _____ Date _____

Spring No. _____; Specimen Volume, ^A V , _____ mL

Spring constant, C , _____ g/cm Elongation: Specimen Density, ^A D , _____

No-Load Scale Reading, N , _____ cm; Specimen Weight, $S = V \times D$, _____

Zero %-Scale Reading, $Z = (N - (S/C))$ _____; Spring Elongation, = S/C _____

Calculation: weight percent Evap. = $\frac{C}{S} \times 100 (B - Z)$

Evaporometer Temperature _____
Relative Humidity _____
Cabinet Temperature _____

^A Measured at $77 \pm 1.0^\circ\text{F}$ ($25 \pm 0.5^\circ\text{C}$).

	SCALE READING (B)	SCALE READING (B-Z)	SPECIMEN EVAPORA- TION % (W)		SCALE READING (B)	SCALE READING (B-Z)	SPECIMEN EVAPORA- TION % (W)
TIME, s				TIME, s			

A3. CALIBRATION OF THE THIN-FILM EVAPOROMETER, AUTOMATIC RECORDING

A3.1 The total deflection of the recording pen in chart units divided by the weight added corresponds to the sensitivity of the apparatus. For example, if the total pen deflection is 60 chart divisions for a 0.500-g weight, the sensitivity factor is 120 chart divisions per gram. This value can then be used to establish the 100 % specimen load at “zero” evaporation time and to calculate the percent evaporated at various time intervals. For instance, pure *n*-butyl acetate (99 mol %) has a density of 0.878 at 25°C, so a 070-mL specimen at the cited calibration would deflect the pen 73.75 chart units (that is, $0.878 \times 0.70 \times 120 = 73.75$). Each 10 % increment that evaporates corresponds to 73.75 chart divisions.

A3.2 *Standardization of the Evaporometer*—Since there may be slight unavoidable variations in manufacture, the evaporometer should be standardized prior to routine usage. Normal butyl acetate (99 % ester) should have a 90 % evaporation time of 470 ± 10 s under the prescribed test conditions. If the evaporation time is outside these limits, a small adjustment should be made to the position of the inlet air (or nitrogen) ports within the inner chamber of the evaporometer. **Warning**—The air should *not* be directed above or onto the filter paper.

A4. VAPORATION RATES OF VOLATILE MATERIALS

A4.1 The evaporation values presented in **Table A4.1** are typical of commercial materials. Deviations from the values shown can be expected due to normal variations in test conditions and purity, composition, source, etc. of test samples.

TABLE A4.1 Evaporation Rates of Volatile Materials

	Automatic Evaporometer		Manual Evaporometer	
	Seconds to 90 % Evaporation	Relative Rate <i>n</i> -Butyl Acetate = 1.0	Seconds to 90 % Evaporation	Relative Rate ^A <i>n</i> -Butyl Acetate = 1.0
Acetone	82	5.7	75	6.0
Amyl acetate (ex. Fusel oil) (85 to 88 %)	690	0.68	680	0.66
Amyl acetate, primary, (mixed isomers) (95 %)	1 200	0.39	1 110	0.41
Amyl alcohol, primary (mixed isomers)	2 300	0.20	...	0.3
<i>tert</i> -Amyl alcohol	505	0.93	430	1.0
Benzene	133	3.5
Isobutyl acetate	305	1.5	305	1.5
<i>n</i> -Butyl acetate (90 %)	460	1.0	450	1.0
<i>n</i> -Butyl acetate (99 %)	470	1.0
<i>sec</i> -Butyl acetate (90 %)	260	1.8	241	1.9
Isobutyl alcohol	740	0.64	640	0.70
<i>n</i> -Butyl alcohol	1 080	0.44	1 010	0.45
<i>sec</i> -Butyl alcohol	565	0.83	490	0.92
Isobutyl isobutyrate	970	0.48	980	0.46
Butyl lactate	14 600	0.03	13 600	0.03
Cyclohexanol	9 200	0.05	...	0.1
Cyclohexanone	1 570	0.30	1 720	0.26
DEGMBE ^B	150 000	0.01	...	0.01
DEGMBE acetate	328 000	0.01	...	0.01
DEGMEE ^B	27 800	0.02
DEGMME ^B	26 300	0.02	...	0.01
Diacetone alcohol	3 840	0.12	4 320	0.10
Diethyl ketone	205	2.3	179	2.5
Diisobutyl ketone	2 430	0.19	2 460	0.18
Dimethyl formamide	2 280	0.21	2 400	0.19
Ethyl acetate (85 %)	115	4.1	110	4.1
Ethyl acetate (95 %)	117	4.0	108	4.2
Ethyl acetate (99 %)	117	4.0	100	4.5
Ethyl alcohol (95 %)	330	1.4
Ethyl alcohol (100 %)	280	1.7
Ethyl amyl ketone	1 770	0.27	2 040	0.22
Ethylbenzene	562	0.84
Ethyl butyl ketone	1 080	0.44	1 020	0.44
Ethyl ether	40	11.8
Ethylene glycol	...	0.01
EGMBE ^B	6 780	0.07	8 100	0.06
EGMBE ^B acetate	14 300	0.03	13 300	0.03
EGMEE ^B	1 210	0.39	1 260	0.36
EGMEE ^B acetate (95 %)	2 700	0.17	2 820	0.16
EGMEE ^B acetate (99 %)	2 520	0.19	2 520	0.18
EGMME ^B	880	0.53
2-Ethyl hexanol	25 700	0.02	...	0.01
2-Ethyl hexyl acetate (95 %)	13 400	0.04	...	0.03
Ethyl lactate	2 580	0.18	2 490	0.18
Hexyl acetate	2 580	0.18	2 400	0.19
Hexylene glycol	...	0.01
<i>n</i> -Hexane	60	7.8
Isophorone	20 000	0.02	27 600	0.02
Mesityl oxide	535	0.88	555	0.81
Methyl acetate (80 %)	93	5.0	93	4.8
Methyl alcohol	220	2.1	220	2.0
Methyl amyl acetate (95 %)	1 000	0.47	900	0.50
Methyl ethyl ketone	121	3.9	112	4.0
Methyl isoamyl ketone	1 020	0.46	1 040	0.43
Methyl isobutyl carbinol	710	0.27	1 790	0.25
Methyl isobutyl ketone	280	1.7	277	1.6
Methyl isopropyl ketone	164	2.9
Methyl <i>n</i> -amyl ketone	1 380	0.34	1 250	0.36
Methyl <i>n</i> -propyl ketone	200	2.4
4-Methoxy – 4-methyl pentanone-2	295	1.6
Nitroethane	445	1.1	390	1.2
Nitromethane	360	1.3	330	1.4
1-Nitropropane	645	0.73	600	0.75
<i>n</i> -Octane	295	1.6
Isopropyl acetate (95 %)	134	3.5	125	3.6
<i>n</i> -Propyl acetate	220	2.1	197	2.3
Isopropyl alcohol	320	1.5	290	1.6
<i>n</i> -Propyl alcohol	530	0.89	450	1.0
Propylene glycol	...	0.01
Isopropyl ether	57	8.2
Tetrahydrofuran	97	4.8	90	5.0
Toluene	235	2.0	229	2.0

TABLE A4.1 *Continued*

	Automatic Evaporimeter		Manual Evaporimeter	
	Seconds to 90 % Evaporation	Relative Rate <i>n</i> -Butyl Acetate = 1.0	Seconds to 90 % Evaporation	Relative Rate ^A <i>n</i> -Butyl Acetate = 1.0
Water	1 290	0.36
Xylene	610	0.77	620	0.73

^A These data are based on tests made with commercial-grade *n*-butyl acetate containing 90 % ester.

^B Key—EGMME, Ethylene glycol monomethyl ether (2-methoxy ethanol), EGME, Ethylene glycol monoethyl ether (2-ethoxy ethanol), EGMBE, Ethylene glycol monobutyl ether (2-butoxy ethanol), DEGMME, Diethylene glycol monomethyl ether, DEGMEE, Diethylene glycol monoethyl ether, DEGMBE, Diethylene glycol monobutyl ether.

ASTM International takes no position respecting the validity of any patent rights asserted in connection with any item mentioned in this standard. Users of this standard are expressly advised that determination of the validity of any such patent rights, and the risk of infringement of such rights, are entirely their own responsibility.

This standard is subject to revision at any time by the responsible technical committee and must be reviewed every five years and if not revised, either reapproved or withdrawn. Your comments are invited either for revision of this standard or for additional standards and should be addressed to ASTM International Headquarters. Your comments will receive careful consideration at a meeting of the responsible technical committee, which you may attend. If you feel that your comments have not received a fair hearing you should make your views known to the ASTM Committee on Standards, at the address shown below.

This standard is copyrighted by ASTM International, 100 Barr Harbor Drive, PO Box C700, West Conshohocken, PA 19428-2959, United States. Individual reprints (single or multiple copies) of this standard may be obtained by contacting ASTM at the above address or at 610-832-9585 (phone), 610-832-9555 (fax), or service@astm.org (e-mail); or through the ASTM website (www.astm.org). Permission rights to photocopy the standard may also be secured from the Copyright Clearance Center, 222 Rosewood Drive, Danvers, MA 01923, Tel: (978) 646-2600; http://www.copyright.com/