



Standard Test Method for Softening Point of Asphalt and Pitch (Mettler Cup-and-Ball Method)¹

This standard is issued under the fixed designation D3461; the number immediately following the designation indicates the year of original adoption or, in the case of revision, the year of last revision. A number in parentheses indicates the year of last reapproval. A superscript epsilon (ϵ) indicates an editorial change since the last revision or reapproval.

1. Scope*

1.1 This test method covers the determination of the softening point of asphalt and pitch in the range from 50 °C to 180 °C by the cup-and-ball apparatus, and gives results comparable to those obtained by Test Method D36.

NOTE 1—If the softening point of asphalt by this Mettler cup-and-ball method fails to meet specified requirements, tests may be rerun using the Test Method D36 (ring-and-ball) softening point apparatus as a referee method.

1.2 *This standard does not purport to address all of the safety concerns, if any, associated with its use. It is the responsibility of the user of this standard to establish appropriate safety and health practices and determine the applicability of regulatory limitations prior to use.*

2. Referenced Documents

2.1 *ASTM Standards:*²

A314 Specification for Stainless Steel Billets and Bars for Forging

D36 Test Method for Softening Point of Bitumen (Ring-and-Ball Apparatus)

D140 Practice for Sampling Bituminous Materials

D4296 Practice for Sampling Pitch

3. Summary of Test Method

3.1 In this test method the softening point is defined as the temperature at which the specimen, suspended in a cylindrical cup with a 6.5 mm hole in the bottom and with a lead ball, 8 mm in diameter, centered on top of the sample in the cup, flows downward a distance of 19 mm to interrupt a light beam, as the sample is heated at a linear rate in air.

¹ This test method is under the jurisdiction of ASTM Committee D02 on Petroleum Products, Liquid Fuels, and Lubricants and is the direct responsibility of Subcommittee D02.05 on Properties of Fuels, Petroleum Coke and Carbon Material.

Current edition approved Oct. 1, 2014. Published November 2014. Originally approved in 1976. Last previous edition approved in 2012 as D3461 – 97 (2012). DOI: 10.1520/D3461-14.

² For referenced ASTM standards, visit the ASTM website, www.astm.org, or contact ASTM Customer Service at service@astm.org. For *Annual Book of ASTM Standards* volume information, refer to the standard's Document Summary page on the ASTM website.

4. Significance and Use

4.1 Asphalt and pitch do not go through a solid-liquid phase change when heated, and therefore do not have true melting points. As the temperature is raised, they gradually soften or become less viscous. For this reason, the determination of the softening point must be made by an arbitrary, but closely defined, method if the test values are to be reproducible.

4.2 This test method is useful in determining the consistency as one element in establishing the uniformity of shipments or sources of supply.

5. Apparatus

5.1 A METTLER TOLEDO dropping point cell³ can be used to determine softening points by this test method. These commercially available instruments consist of a control unit with a digital temperature indicator with furnace built in or attached, sample cartridges, and accessories. The control unit automatically regulates the heating rate of the furnace. The softening point is indicated on the readout, and the heating program stopped, when the sample flow triggers the softening point detection. A general view of the components of the METTLER TOLEDO softening point instrument is shown in Fig. 1 (old instrument) and Fig. 2 (new instrument).

5.1.1 *Integrated or Separate Control Unit*—The control unit shall provide a continuous, linear temperature increase from 25 °C to 250 °C at a rate of 2 °C/min. A digital readout shall indicate the temperature to 0.1 °C throughout.

5.1.2 *Integrated or Separate Furnace Unit*—The furnace unit shall be capable of heating one or two sample cup assemblies, as described in 5.1.3, at a linear rate of 2 °C ± 0.3 °C/min. It shall include a sensing system capable of detecting the softening point with a precision of 0.1 °C.

5.1.3 *Sample Cup Assembly*—A cup of chromium-plated brass, or of aluminum, or of stainless steel conforming to the requirements for Type 303 (UNS S30300) stainless steel as

³ The sole source of supply of the apparatus known to the committee at this time is available from Mettler-Toledo, LLC., 1900 Polaris Pkwy, Columbus, OH 43240, www.mt.com. If you are aware of alternative suppliers, please provide this information to ASTM International Headquarters. Your comments will receive careful consideration at a meeting of the responsible technical committee,¹ which you may attend.

*A Summary of Changes section appears at the end of this standard

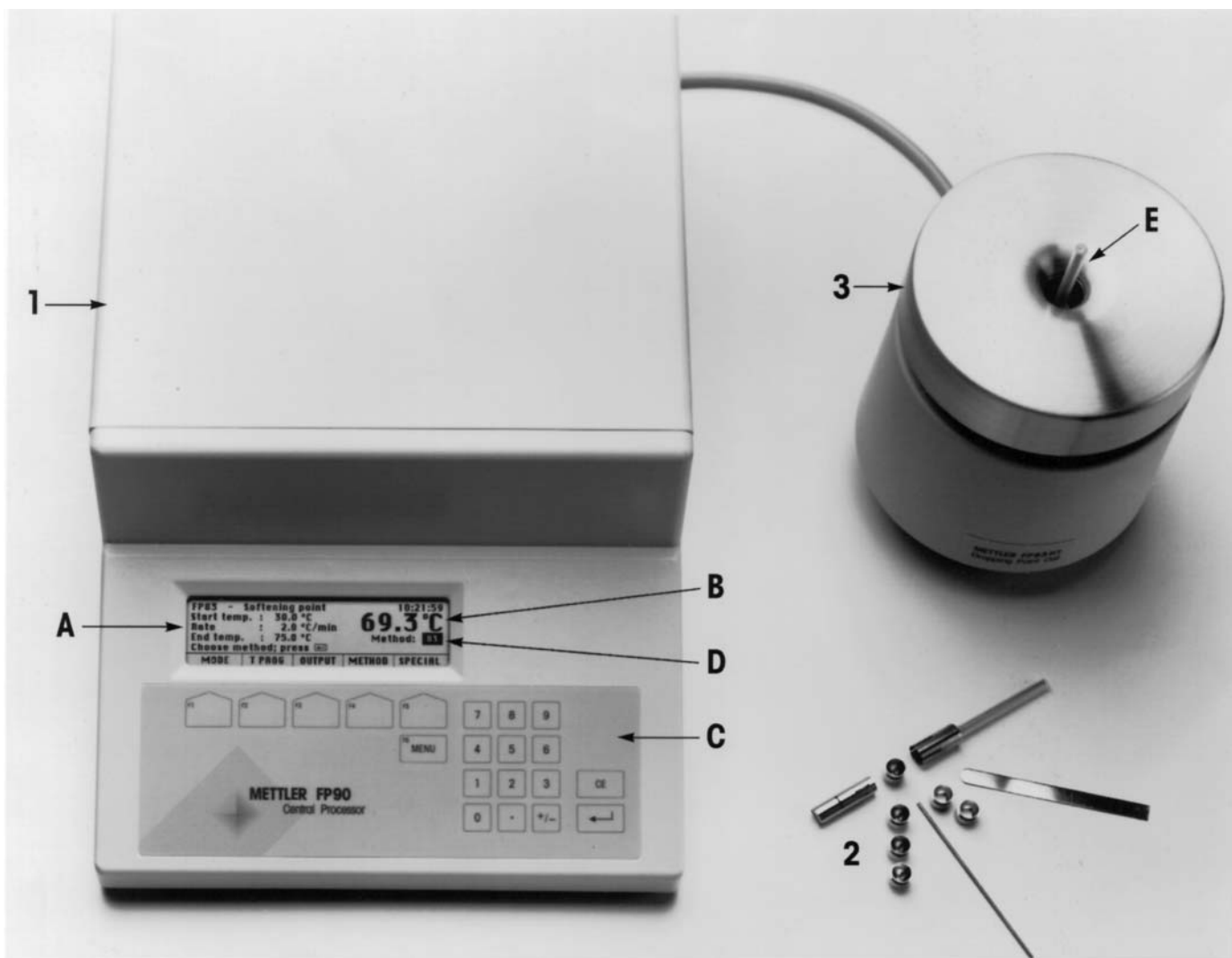

General View of the METTLER TOLEDO FP90/FP83HT

- | | |
|--|--|
| <p>1 Control and evaluation unit
 A LCD with guide for operator
 B Temperature display
 C Keyboard with function keys F1 to F6
 D Selected method number</p> | <p>2 Cartridges with accessories
 3 Measuring cell FP83HT
 E Sample holder</p> |
|--|--|

FIG. 1 General View of the METTLER TOLEDO FP90 Control Unit with Heater FP83HT

prescribed in Specification **A314**, with the dimensions shown in **Fig. 3**. It shall be placed in the assembly so that the pitch sample softening point will be detected when it has flowed down a distance of 19 mm.

5.1.4 *Lead Ball*—A lead ball weighing $3.20 \text{ g} \pm 0.10 \text{ g}$. A 32-caliber lead shot is suitable for this purpose.

6. Reagents

6.1 *Xylene*, industrial grade.

7. Calibration of METTLER TOLEDO Apparatus

7.1 This step, required only occasionally, is designed to establish that the temperature indicated by the instrument is in

agreement with a known standard. A special cup with a bottom orifice of 2.8 mm is used instead of the one prescribed for the testing of pitch.

7.2 *Reagent*—Use either analytical reagent or primary standard grade benzoic acid for the calibration. As this material is hygroscopic it must be stored in a tightly sealed container, and replaced with fresh material from a newly opened supply if hydration or other contamination is suspected.



FIG. 2 General View of the METTLER TOLEDO DP70

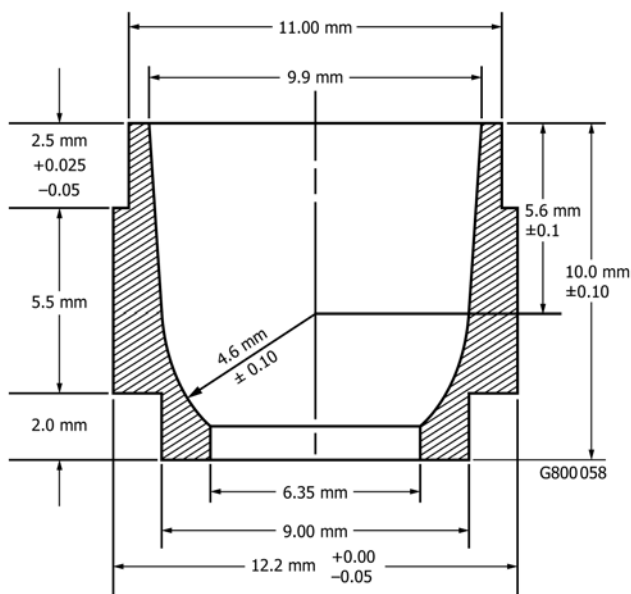

FIG. 3 Specimen Cup

7.3.1 *Filling the Sample Cup*—Place the cup on a clean, flat surface. Add a small amount of benzoic acid crystals and press down with a rod (approximately 4.5 mm in diameter). Check that the bottom orifice is completely filled. Refill and repeat the pressing step until the cup is filled with benzoic acid. Remove any crystals from the exterior of the cup.

7.3.2 *Heating*—Preheat the Mettler furnace to 121 °C, and maintain it at that temperature. Place the cartridge assembly containing the benzoic acid in position in the furnace, taking care that the slits for the light beam are properly positioned. Wait for temperature equilibration, that is, the furnace and the sample are in equilibrium at the preset temperature, but not less than the 30 s after inserting the cartridge, start the automatic heating cycle at 0.2 °C/min. The temperature will rise steadily at the correct rate until the drop point is reached, and then remain steady on the readout.

7.3.3 *Cleaning*—Immediately remove the cartridge assembly. Check to determine that the sample has passed through the light beam and no pre-triggering has occurred. If a malfunction is suspected, the entire procedure must be repeated. Inspect the apparatus carefully to ensure that no residue remains. Use a spatula shaped to the contour of the cup to remove most of the

7.3 Procedure—Old Instruments:

remaining acid from the cup and from the bottom of the cartridge. Wash the cup and cartridge in xylene, or other suitable solvent, to remove the last traces of the residue.

7.4 *Interpretation*—See 7.6.

7.5 *Procedure—New Instruments:*

7.5.1 *Filling the Sample Cup*—Place the cup on a clean, flat surface. Optionally, the sample preparation tool may be used. See Fig. 2. Add a small amount of benzoic acid crystals and press down with a rod (approximately 4.5 mm in diameter). Check that the bottom orifice is completely filled. Refill and repeat the pressing step until the cup is filled with benzoic acid. Remove any crystals from the exterior of the cup. Place a glass collector below the cup and a cup cap on top, and place in the sample carrier. Two cup assemblies may be placed in the sample carrier.

7.5.2 *Heating*—Preheat the furnace to 121 °C and maintain it at that temperature. Place the sample carrier containing the benzoic acid in position in the furnace. Wait for temperature equilibration, that is, the furnace and the sample are in equilibrium at the preset temperature, but not less than 30 s after inserting the cartridge, start the automatic heating cycle at 0.2 °C/min. The temperature will rise steadily at the correct rate until the drop point is reached, and then remain steady on the readout. If there are two samples, heating will continue until both have dropped.

7.5.3 *Cleaning*—Immediately remove the cartridge assembly. Check to determine that the sample has dropped and no pre-triggering has occurred. The video may be viewed to make sure the drop was detected correctly. If a malfunction is suspected, the entire procedure must be repeated. Inspect the apparatus carefully to ensure that no residue remains. Use a spatula shaped to the contour of the cup to remove most of the remaining acid from the cup. Wash the cup and glass collector in xylene, or other suitable solvent, to remove the last traces of the residue. Glass collectors may be treated as disposable items. Aluminum cups may be used which may also be considered to be disposable.

7.6 *Interpretation*—If the result is not $123.5\text{ °C} \pm 0.5\text{ °C}$, repeat the test. If the second value is 0.6 °C above or below 123.5 °C, measure the dropping point of a fresh sample of benzoic acid. If the deviation exceeds 0.6 °C, the instrument requires recalibration or repair. Consult the manufacturer's instruction manual.

8. Sampling

8.1 Samples from shipments shall be taken in accordance with Practice D140 for asphalt and Practice D4296 for pitch and shall be free of foreign substances. Thoroughly mix the sample before removing a representative portion for the determination or for dehydration.

8.2 *Pitch Sample Preparation:*

8.2.1 If a solid bulk sample contains free water, air-dry a representative portion at 60 °C or below.

8.2.2 If the sample is liquid, check for any surface foam which may indicate the presence of water. If foam is found, maintain the sample at a temperature of about 125 °C in an open container until the surface is free of foam. Take care not

to overheat. Remove from the heat source as soon as the foam has subsided. Proceed as directed in 9.1.

8.2.3 Crush air-dry lumps of pitch to a size of 6 mm to 12 mm. Add the material to a container, having a height equal to or exceeding its width, and having a volume of not less than 50 mL, until it is about half full. Place the container on a hot plate, or in an oven or a bath. Do not use an open flame for melting pitch. After melting is complete, stir gently but thoroughly, avoiding incorporation of air bubbles. The maximum temperature of the molten pitch should not exceed the expected softening point by more than 50 °C. Any foam that forms must be skimmed off.

8.3 *Asphalt Sample Preparation:*

8.3.1 Heat the sample, with care to prevent local overheating, constantly stirring until it has become sufficiently fluid to pour. In no case, however, shall the temperature be raised more than 110 °C (200 °F) above the expected softening point for asphalt. Avoid incorporating air bubbles in the sample.

8.3.2 Bring the asphalt sample to the pouring temperature in not more than 2 h.

9. Test Specimen

9.1 Prepare the test specimen by slightly overfilling the specimen cup, which rests on a brass plate. Optionally, the sample preparation tool may be used (see Fig. 2). Keep the lip of the container close to the top of the cup to minimize entrainment of air bubbles. Under-pouring past the blade of a spatula is helpful in this respect. Cool the specimen in the cup until firm, under cold water if necessary. Trim the specimen flush with the top of the cup by pressing with a heated knife or spatula while drawing it toward you. Support the cup with tweezers or forceps or in a wood block with holes sized to fit the cup. Do not trim by cutting across the top with a forward or sideward motion as this tends to lift the specimen out of the mold, thus creating an internal void which is not easily detected, and which significantly alters the result.

9.2 An alternative method which avoids possible loss of volatiles in re-melting, is to press the cold, solid specimen into the specimen cup. Select clean, dry, dust-free lumps from the representative portion of the sample and crush to a size of less than 2 mm. Place a sample cup in the mold (see Fig. 4, Fig. 5, and Fig. 6). Place the assembled mold, with the knockout pin in position, on the bottom plate of a hydraulic press. Pour about 2 g of the crushed specimen into the top of the mold and insert the top ram. Compress the specimen into the cup with a total force on the ram of 22.24 kN (5000 lb). Hold this pressure for a minimum of 15 s. Excessive molding pressure can cause the specimen cup to fail by shearing. Remove the mold assembly from the press and rotate the upper half while keeping the lower half of the mold stationary. This action causes the specimen to shear horizontally at the top of the cup. Separate the two parts of the mold and remove the specimen cup from the bottom half. It may be necessary to dislodge it by pressing against the knockout pin. A small-diameter rod mounted on the base plate may be used for this. Clean the mold of all residual material to avoid misalignment or binding during subsequent use. This procedure does not work well for pitches having

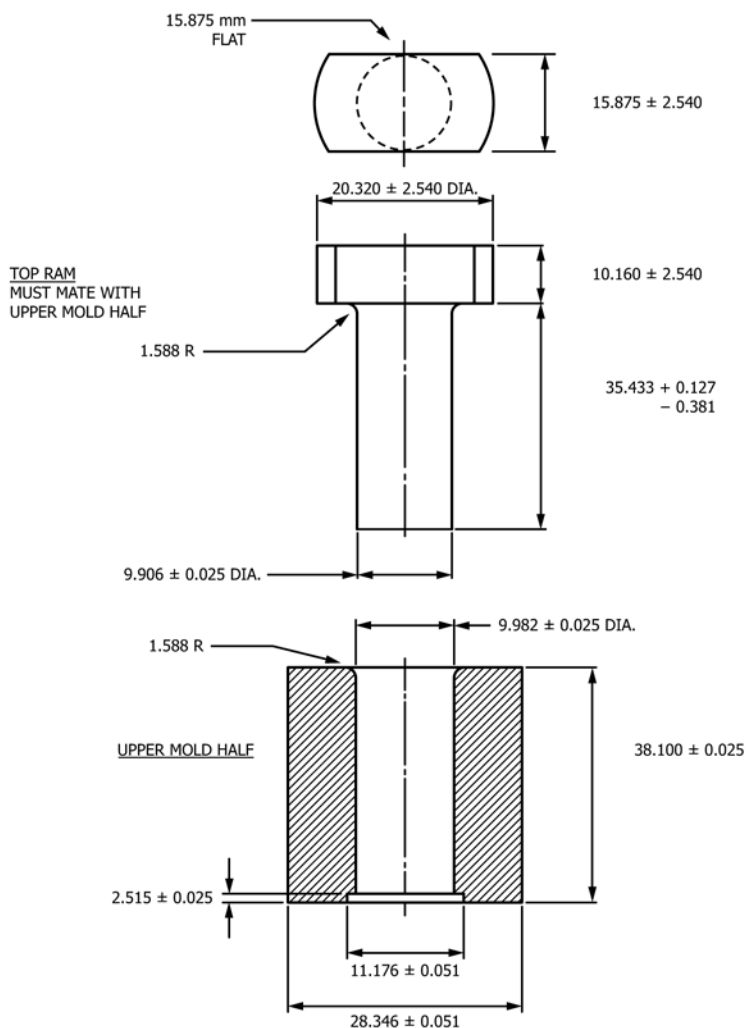

NOTE 1—Diameters are concentric. These two parts will be hardened tool steel and then ground to final dimensions. All dimensions are in millimetres.

FIG. 4 Upper Half of Mold Assembly for Pressure Molding Asphalt and Pitch into a Specimen Cup

softening points below 80 °C unless the mold is precooled below room temperature.

10. Procedure

10.1 The procedure described in this test method for measuring the softening point of asphalts and pitches using either METTLER TOLEDO instruments has been developed to duplicate the results obtained by Test Method D36.

10.2 *Old Instruments*—Preset the temperature of the furnace from 20 °C to 25 °C below the expected softening point of the specimen and maintain at this temperature for a few minutes (see Note 2). Place the specimen cup in the cartridge with the lead ball carefully centered on top of the specimen. The ball may be warmed slightly to form a small indentation and ensure its proper positioning in the furnace during the test. Place the cartridge assembly in the furnace, taking care that the slits for the light beam are properly positioned. Wait for temperature equilibration, that is, the furnace and the sample are in equilibrium at the preset temperature, but not less than 30 s after inserting the cartridge, start the automatic heating cycle at 2 °C/min. Heating will be maintained at this rate until the drop

point is reached, after which a steady temperature will be displayed on the digital readout. Record this temperature as the softening point of the specimen.

NOTE 2—In the event of a dispute, the purchaser and supplier shall agree on the exact starting temperature to be used.

10.3 *Old Instruments*—Immediately remove the cartridge assembly upon completion of the test. Check to ensure that the sample has passed through the light beam and no pre-triggering has occurred. If a malfunction is suspected, reject the result and repeat the test. Inspect the apparatus closely to ensure that no particles of residue remain.

10.4 *New Instruments*—Preset the temperature of the furnace from 20 °C to 25 °C below the expected softening point of the specimen and maintain at this temperature for a few minutes (see Note 3). Place the specimen cup in the sample carrier with the lead ball carefully centered on top of the specimen, a cup cap on top of the cup, and a glass receiver below. The ball may be warmed slightly to form a small indentation and ensure its proper positioning in the furnace during the test. Place the sample carrier in the furnace. Wait for temperature equilibration, that is, the furnace and the sample

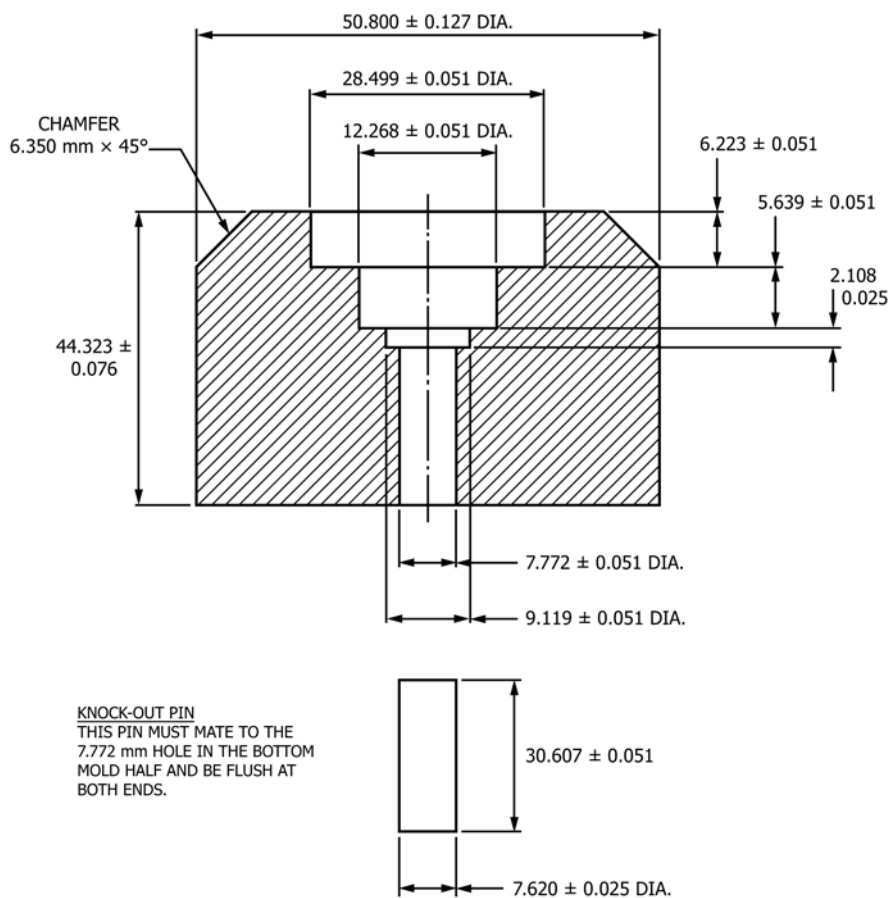

NOTE 1—Diameters are concentric. These two parts will be made of stainless steel. All dimensions are in millimetres.

FIG. 5 Lower Half of Mold Assembly for Pressure Molding Asphalt and Pitch into a Specimen Cup

are in equilibrium at the preset temperature, but not less than 30 s after inserting the cartridge, start the automatic heating cycle at 2 °C/min. Heating will be maintained at this rate until the softening point is reached, after which a steady temperature will be displayed on the digital readout. Record this temperature as the softening point of the specimen.

NOTE 3—In the event of a dispute, the purchaser and supplier shall agree on the exact starting temperature to be used.

10.5 *New Instruments*—Immediately remove the cartridge assembly upon completion of the test. Check to ensure that the sample has dropped and no pre-triggering has occurred. The video may be viewed to make sure the drop was detected correctly. If a malfunction is suspected, reject the result and repeat the test. Inspect the apparatus closely to ensure that no particles of residue remain.

10.6 Clean the specimen cups by placing them upside down on a hard surface and punching out any residual material. Use a spatula, shaped to the contour of the cup, with a swirling motion to remove any remaining particles. Inspect and clean the lead ball to remove any residue. Take care to avoid any distortion during this step. Washing with xylene, or other suitable solvent, may be necessary to get the apparatus completely clean.

11. Report

11.1 Report the softening point, as indicated by the digital readout, to the nearest 0.1 °C. If converting to degrees Fahrenheit, report to the nearest 0.2 °F. Experience indicates that duplicate determinations are unnecessary. If any error occurs, or is suspected, in carrying out the details of this procedure, discard the results and make a second run.

12. Precision

12.1 The following criteria shall be used for judging the acceptability of any result (95 % confidence level):

12.1.1 *Repeatability*—Duplicate values by the same operator shall not be considered suspect unless they differ by more than 0.5 °C.

12.1.2 *Reproducibility*—The values reported by each of two laboratories shall not be considered suspect unless they differ by more than 1.5 °C.

12.1.3 *Bias*—The procedure in Test Method D3461 for softening point has no bias because the value of softening point is defined only in the terms of this test method.

13. Keywords

13.1 asphalt; METTLER TOLEDO; pitch; softening point

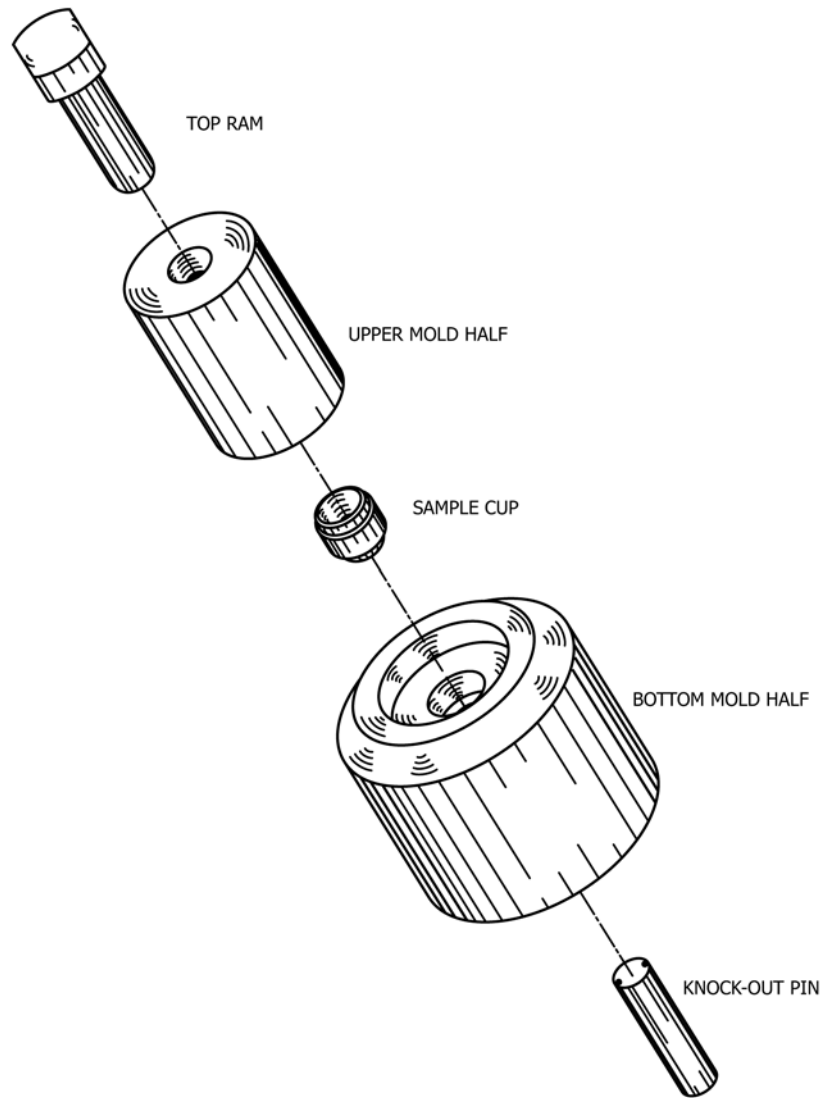

FIG. 6 Assembly of Mold for Pressure Molding Asphalt and Pitch into a Specimen Cup

SUMMARY OF CHANGES

Subcommittee D02.05 has identified the location of selected changes to this standard since the last issue (D3461 – 97 (2012)) that may impact the use of this standard. (Approved Oct. 1, 2014.)

(1) Updated METTLER TOLEDO model number and procedure; added new [Fig. 2](#).

ASTM International takes no position respecting the validity of any patent rights asserted in connection with any item mentioned in this standard. Users of this standard are expressly advised that determination of the validity of any such patent rights, and the risk of infringement of such rights, are entirely their own responsibility.

This standard is subject to revision at any time by the responsible technical committee and must be reviewed every five years and if not revised, either reapproved or withdrawn. Your comments are invited either for revision of this standard or for additional standards and should be addressed to ASTM International Headquarters. Your comments will receive careful consideration at a meeting of the responsible technical committee, which you may attend. If you feel that your comments have not received a fair hearing you should make your views known to the ASTM Committee on Standards, at the address shown below.

This standard is copyrighted by ASTM International, 100 Barr Harbor Drive, PO Box C700, West Conshohocken, PA 19428-2959, United States. Individual reprints (single or multiple copies) of this standard may be obtained by contacting ASTM at the above address or at 610-832-9585 (phone), 610-832-9555 (fax), or service@astm.org (e-mail); or through the ASTM website (www.astm.org). Permission rights to photocopy the standard may also be secured from the Copyright Clearance Center, 222 Rosewood Drive, Danvers, MA 01923, Tel: (978) 646-2600; <http://www.copyright.com/>