



Standard Test Methods for Measurement of Energy and Integrated Charge Transfer Due to Partial Discharges (Corona) Using Bridge Techniques¹

This standard is issued under the fixed designation D3382; the number immediately following the designation indicates the year of original adoption or, in the case of revision, the year of last revision. A number in parentheses indicates the year of last reapproval. A superscript epsilon (ϵ) indicates an editorial change since the last revision or reapproval.

1. Scope*

1.1 These test methods cover two bridge techniques for measuring the energy and integrated charge of pulse and pseudoglow partial discharges:

1.2 Test Method A makes use of capacitance and loss characteristics such as measured by the transformer ratio-arm bridge or the high-voltage Schering bridge (Test Methods D150). Test Method A can be used to obtain the integrated charge transfer and energy loss due to partial discharges in a dielectric from the measured increase in capacitance and $\tan \delta$ with voltage. (See also IEEE 286 and IEEE 1434)

1.3 Test Method B makes use of a somewhat different bridge circuit, identified as a charge-voltage-trace (parallelogram) technique, which indicates directly on an oscilloscope the integrated charge transfer and the magnitude of the energy loss due to partial discharges.

1.4 Both test methods are intended to supplement the measurement and detection of pulse-type partial discharges as covered by Test Method D1868, by measuring the sum of both pulse and pseudoglow discharges per cycle in terms of their charge and energy.

1.5 *This standard does not purport to address all of the safety concerns, if any, associated with its use. It is the responsibility of the user of this standard to establish appropriate safety and health practices and determine the applicability of regulatory limitations prior to use.* Specific precaution statements are given in Section 7.

2. Referenced Documents

2.1 ASTM Standards:²

D150 Test Methods for AC Loss Characteristics and Permit-

tivity (Dielectric Constant) of Solid Electrical Insulation
D1711 Terminology Relating to Electrical Insulation
D1868 Test Method for Detection and Measurement of Partial Discharge (Corona) Pulses in Evaluation of Insulation Systems

2.2 IEEE Documents³

IEEE 286 Recommended Practice for Measurement of Power Factor and Power Factor Tip-up for Rotating Machine Stator Coil Insulation

IEEE 1434 Guide to the Measurement of Partial Discharges in Rotating Machinery

IEEE C57.113 Guide for PD Measurements in Liquid-Filled Power Transformers

IEEE Standard C57.124 Recommended Practice for the Detection of PD and the Measurement of Apparent Charge in Dry-Type Transformers

2.3 AEIC Documents⁴

AEIC T-24-380 Guide for Partial Discharge Procedure

AEIC CS5-87 Specifications for Thermoplastic and Cross-linked Polyethylene Insulated Shielded Power Cables Rated 5 through 35 kV, 9th Edition, 1987

3. Terminology

3.1 Definitions:

3.1.1 *pseudoglow discharge, n*—a type of partial discharge, which takes place within an expanded discharge channel and is characterized by pulses of relatively low magnitude and long rise time.

3.1.1.1 *Discussion*—Pseudoglow discharges occur within a diffused discharge channel, whose emitted glow fills the entire intervening gap or cavity space (1). The discharge rate behavior as a function of applied voltage is similar to that of the rapid rise time pulse (spark-type) discharges. The successive pseudoglow discharge pulses occur over the first quadrant of each half cycle and in some gases, notably helium, their magnitude is found to diminish to zero. At this point, a transition to a pulseless glow discharge can occur. Its occurrence, which is manifest by distortion in the sinusoidal voltage wave, is rare.

¹ These test methods are under the jurisdiction of ASTM Committee D09 on Electrical and Electronic Insulating Materials and are the direct responsibility of Subcommittee D09.12 on Electrical Tests.

Current edition approved Nov. 1, 2013. Published December 2013. Originally approved in 1975. Last previous edition approved in 2007 as D3382 – 07. DOI: 10.1520/D3382-13.

² For referenced ASTM standards, visit the ASTM website, www.astm.org, or contact ASTM Customer Service at service@astm.org. For *Annual Book of ASTM Standards* volume information, refer to the standard's Document Summary page on the ASTM website.

³ Available from Institute of Electrical and Electronics Engineers, Inc. (IEEE), 445 Hoes Ln., P.O. Box 1331, Piscataway, NJ 08854-1331, http://www.ieee.org.

⁴ Available from The Association of Edison Illuminating Companies (AEIC), 600 N. 18th St, Birmingham, AL 35291, www.aeic.org.

*A Summary of Changes section appears at the end of this standard

At discharge inception of a single cavity, the pattern of pseudoglow discharges consists of a single long rise time discharge current pulse in each half-cycle. It has become common practice to refer to this particular type of pattern as that of a glow discharge.

Pseudoglow partial discharges, which occur at low gas pressures, such as in insulating systems of electrical equipment for aerospace applications, have unduly long rise times and a frequency spectrum that falls below the bandwidth of conventional partial discharge pulse detectors (2). As a consequence, they cannot be detected by the partial discharge detectors specified in Test Method D1868; however they can be detected and measured by either Method A or B of Test Methods D3382.

3.1.2 *pulse discharge, n*—a type of partial-discharge phenomenon characterized by a spark-type breakdown which occurs in a narrow constricted channel.

3.1.2.1 *Discussion*—The resultant detected pulse discharge has a short rise time and its Fourier frequency spectrum may extend as far as 1 GHz. Such a pulse discharge may be readily detected by conventional pulse detectors, that are generally designed for partial-discharge measurements within the frequency band from 30 kHz to several megahertz. (See also IEEE 1434, IEEE C57.113, IEEE C57.124, AEIC T-24-380, and AEIC CS5-87.)

3.1.3 *pulseless-glow discharge, n*—an uncommon type of partial discharge, whose existence is manifest not by the usual abrupt voltage fall discontinuities in the sinusoidal voltage wave at each discharge epoch but rather by distortions in the waveform.

3.1.3.1 *Discussion*—It is generally found that the pulseless glow region develops only when preceded by a pseudoglow discharge in which the abrupt voltage collapse magnitudes at each discharge have gradually diminished in the limit to zero. The nature of this pulseless glow region is not fully understood, but it is believed to consist of a very weakly ionized gas volume. Further increases in the applied voltage can lead to more complex partial discharge patterns, consisting of regions of pseudoglow, pulseless and pulse type discharges (3). Pulse type partial discharge detectors of the type described in Test Method D1868 cannot be employed to detect pulseless glow discharges.

3.1.4 See (1) and (3) for more information on the previous definitions.

3.1.5 For definitions of other terms pertaining to this standard refer to Terminology D1711.

3.2 Symbols:

3.2.1 Refer to Annex A1 for symbols for mathematical terms used in this standard.

4. Summary of Test Methods

4.1 It is possible to represent the dielectric characteristics of a specimen of solid insulating material by a parallel combination of capacitance and conductance. The values of capacitance and conductance remain practically constant over the useful range of alternating voltage stress at a fixed frequency. If, however, the specimen contains gaseous inclusions (cavities), incremental increases in capacitance and conductance occur as the voltage stress is raised above the value necessary to initiate

partial discharges in the cavities. The energy loss in the incremental conductance is considered to be that dissipated by the partial discharges.

4.2 In Test Method A an initial measurement is made of the capacitance and loss characteristic of the specimen at an applied voltage below the discharge inception level. The voltage is then raised to the specified test value and a second measurement made. The energy loss due to partial discharges is calculated from the results of the two measurements.

4.3 In Test Method B a special bridge circuit is balanced at a voltage below the discharge inception level. The voltage is then raised to the specified test value, but the bridge is not rebalanced. Any unbalanced voltage at the detector terminals is displayed in conjunction with the test voltage on an oscilloscope. The oscilloscope pattern approximates a parallelogram, the area of which is a measure of the energy loss due to partial discharges.

5. Significance and Use

5.1 These test methods are useful in research and quality control for evaluating insulating materials and systems since they provide for the measurement of charge transfer and energy loss due to partial discharges (4) (5) (6).

5.2 Pulse measurements of partial discharges indicate the magnitude of individual discharges. However, if there are numerous discharges per cycle it is occasionally important to know their charge sum, since this sum can be related to the total volume of internal gas spaces that are discharging, if it is assumed that the gas cavities are simple capacitances in series with the capacitances of the solid dielectrics (7) (8).

5.3 Internal (cavity-type) discharges are mainly of the pulse (spark-type) with rapid rise times or the pseudoglow-type with long rise times, depending upon the discharge governing parameters existing within the cavity. If the rise times of the pseudoglow discharges are too long, they will evade detection by pulse detectors as covered in Test Method D1868. However, both the pseudoglow discharges irrespective of the length of their rise time as well as pulseless glow can be readily measured either by Method A or B of Test Methods D3382.

5.4 Pseudoglow discharges have been observed to occur in air, particularly when a partially conducting surface is involved. It is possible that such partially conducting surfaces will develop with polymers that are exposed to partial discharges for sufficiently long periods to accumulate acidic degradation products. Also in some applications, like turbogenerators, where a low molecular weight gas such as hydrogen is used as a coolant, it is possible that pseudoglow discharges will develop.

6. Sources of Errors

6.1 *Surface Discharges*—All discharges in the test specimen are measured, whether on the surface or in internal cavities. If it is desired to measure only internal cavities, the other discharges must be avoided. In the case of an insulated conductor with an outer electrode on the surface (such as a cable or generator coil), the surface discharges at the end of this outer electrode can be removed from the measurement with a

closely-spaced guard ring connected to ground. See Section 4 of Test Methods D150.

6.2 Since tests will be made at ionizing voltage, all connections making up the complete high-voltage circuit should be free of corona to avoid measurement interference. See Section 5 of Test Method D1868.

6.3 Anomalous changes in insulation losses with changes in voltage stress can occur as a result of phenomena other than partial discharges. Such losses are a source of error in these methods, since they are indistinguishable from discharge losses. However, these losses are often negligible in comparison with partial discharge losses.

6.4 It is possible that any temperature change in the specimen between the times at which the low-voltage and high-voltage measurements are taken will cause a change in the normal losses and appear as changes in discharge energy, thus causing an error in test results. This situation can be recognized in Method B and corrective action taken (see 11.3).

6.5 Paint used to grade potential on the surface of some insulation specimens (for example, generator stator coil) shall not be included in the measurement, since it is possible that the conductance of such paints will change with voltage and affect the accuracy of the method as a measure of discharge energy. It is sometimes possible to exclude the painted surfaces from the measuring circuit by the use of guarding or shielding techniques.

7. Hazards

7.1 **Warning**— *It is possible that lethal voltages will be present during this test. It is essential that the test apparatus, and all associated equipment potentially electrically connected to it, be properly designed and installed for safe operation. Solidly ground all electrically conductive parts that any person might come in contact with during the test. Provide means for use at the completion of any test to ground any parts which: were at high voltage during the test; have the potential to have acquired an induced charge during the test; have the potential to retain a charge even after disconnection of the voltage source. Thoroughly instruct all operators in the proper way to conduct tests safely. When making high voltage tests, particularly in compressed gas or in oil, it is possible that the energy released at breakdown will be sufficient to result in fire, explosion, or rupture of the test chamber. Design of test equipment, test chambers, and test specimens shall be such as to minimize the possibility of such occurrences and to eliminate the possibility of personal injury.*

7.2 **Warning**— *Ozone is a physiologically hazardous gas at elevated concentrations. The exposure limits are set by governmental agencies and are usually based upon recommendations made by the American Conference of Governmental Industrial Hygienists.⁵ Ozone is likely to be present whenever voltages exist which are sufficient to cause partial, or complete, discharges in air or other atmospheres that contain oxygen. Ozone has a distinctive odor which is initially discernible at*

low concentrations but sustained inhalation of ozone can cause temporary loss of sensitivity to the scent of ozone. Because of this it is important to measure the concentration of ozone in the atmosphere, using commercially available monitoring devices, whenever the odor of ozone is persistently present or when ozone generating conditions continue. Use appropriate means, such as exhaust vents, to reduce ozone concentrations to acceptable levels in working areas.

TEST METHOD A

8. Procedure

8.1 Conventional circuits for the measurement of alternating-voltage capacitance and loss characteristics of insulation can be used for this method. The transformer-ratioarm bridge shown in Fig. 1, or the Schering bridge shown in Fig. X4.2 of Test Methods D150 are well suited to this application.

8.2 Energize the test specimen at a low voltage, V_1 , below the discharge-inception voltage, and measure capacitance C_{x1} and dissipation factor $\tan \delta_1$. Raise the voltage to a specified test level, V_2 , and repeat the measurements for C_{x2} and $\tan \delta_2$. Calculate the power loss, ΔP , in watts due to discharges at voltage V_2 as follows:

$$\Delta P = \omega V_2^2 (C_{x2} \tan \delta_2 - C_{x1} \tan \delta_1) \tag{1}$$

$$= P_2 - (P_1 V_2^2 / V_1^2) \tag{2}$$

8.3 The increment of dissipation factor $\tan \delta_2 - \tan \delta_1$, called delta tan delta, and written $\Delta \tan \delta$, is often used as an index of discharge intensity.

9. Precision and Bias

9.1 This test method has been in use for many years, but no statement for precision has been made and no activity is planned to develop such a statement.

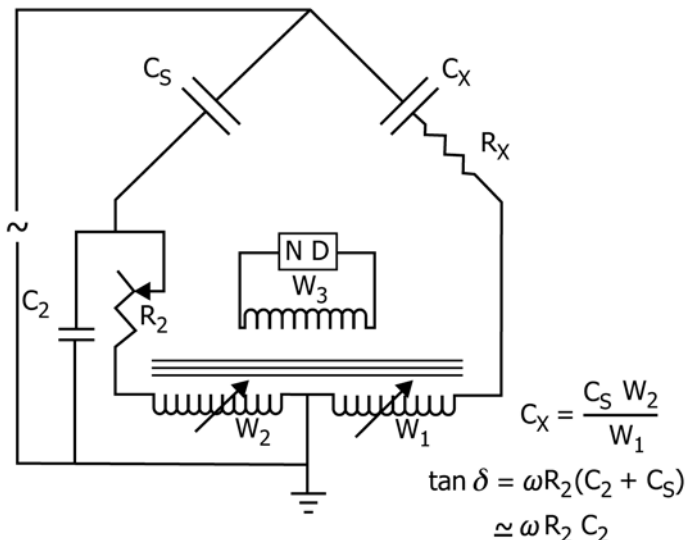

FIG. 1 Typical Transformer-Ratio-Arm Bridge (Method A)

⁵ 1330 Kemper Meadow Drive, Suite 600, Cincinnati, OH 45200.

9.2 A statement of bias is not possible due to the lack of a standard reference material.

10. Interferences

10.1 Harmonics—The test voltage must be reasonably free of harmonics in order to produce the required horizontal line below the inception voltage. Harmonics will produce a wavy rather than a flat line. If the waviness is too severe, the voltage source will have to be filtered to remove the harmonics. The removal of harmonics is more important when the quantities to be measured are small.

TEST METHOD B

11. Procedure

11.1 The test method requires the placing of the test specimen, considered essentially as a high-voltage capacitor, in series with a low-voltage capacitor, across a sinusoidal test-voltage source. See Fig. 2. Two other bridge arms provide a voltage for balancing, at an applied voltage level below inception of partial discharges, the sinusoidal voltage across the low-voltage capacitor. Any partial discharges that occur at higher applied voltages in the specimen will be integrated by the low-voltage capacitor to produce an unbalanced voltage. The unbalanced voltage controls the vertical deflection of an oscilloscope beam, while a voltage proportional to, and in phase with the test voltage, controls the horizontal deflection. A description of a suitable circuit for this test method is detailed in Annex A2.

11.2 The oscilloscope display is simply a horizontal line below the discharge inception voltage where no unbalanced voltages occur. Above the discharge inception voltage the display opens into an approximate parallelogram. The height of the parallelogram represents the sum of the partial discharges per half cycle, and the area represents the energy dissipated per cycle by the discharges. See Fig. 3.

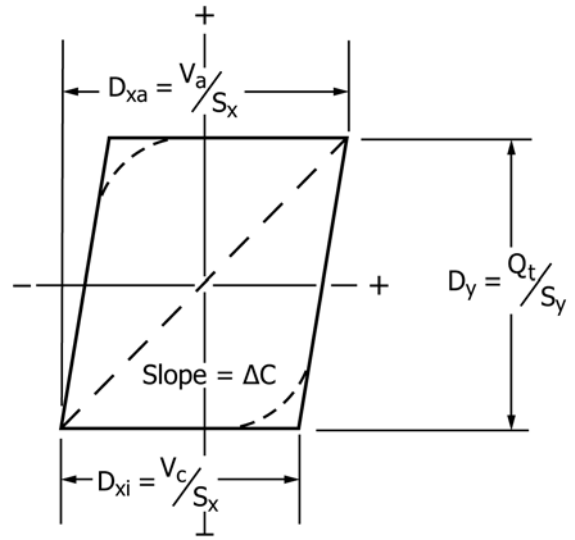

- V_c = discharge inception voltage peak to peak
- V_a = applied voltage peak to peak
- $D_y S_y$ = Q_t coulombs per half cycle
- $S_y S_x A$ = W joules per cycle
- A = area = $D_{xi} D_y$
- ΔC = slope = $C'_x - C_x = D_y S_y / D_{xa} S_x$

FIG. 3 Idealized Loop Trace (Method B)

11.3 If the parallelogram has been tilted or distorted by the increase in voltage, a small adjustment in the capacitance and resistance balance can be made to make the top and bottom of the parallelogram horizontal. This will compensate for some changes in capacitance and $\tan \delta$ due to effects other than partial discharges.

12. Calibration of Oscilloscope Coefficients

12.1 In order to evaluate the parallelogram, it is necessary to determine the deflection sensitivities of the oscilloscope. See Fig. 3. The horizontal-deflection sensitivity, S_x , in volts per

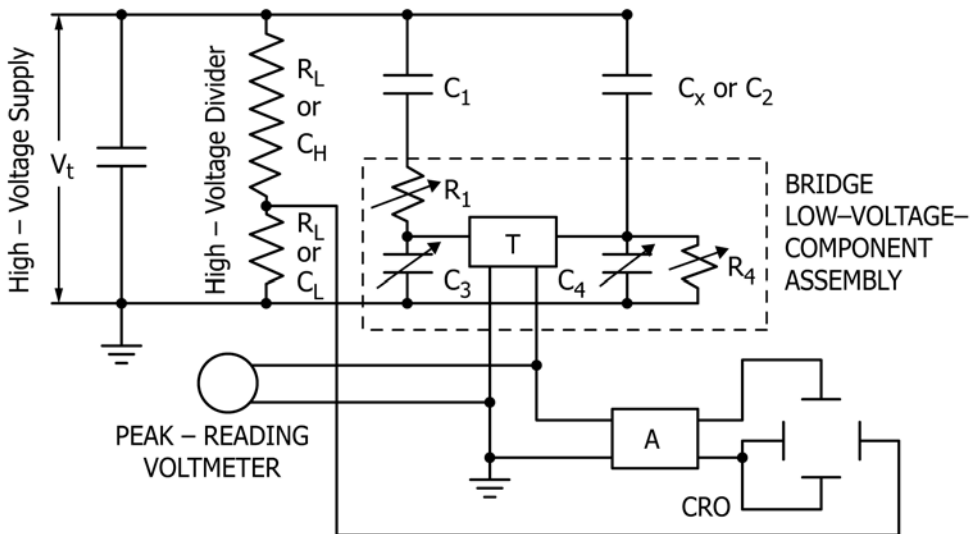

FIG. 2 Typical Charge-Voltage-Trace Bridge (Method B)

centimetre, is found from observing the horizontal deflection, D_{xi} or D_{xa} , in centimetres, to a test voltage having a peak-to-peak value of V_c or V_a as measured by accurate independent means.

$$S_x = V_c/D_{xi} = V_a/D_{xa} \quad (3)$$

12.2 Assess the vertical-deflection sensitivity, S_y , in coulombs per centimetre, by observing the vertical deflection, D_y , in centimetres, to a known charge, Q_c , in coulombs, by a square-wave generator having a peak-to-peak voltage, E_c , coupled to the low-voltage capacitor through a calibrating capacitor, C_c , of a much smaller value. The square-wave frequency needs to be of the same order as the test frequency.

$$S_y = Q_c/D_y = E_c C_c/D_y \quad (4)$$

12.3 Alternatively, determine Q_t , in coulombs, from the turns ratio, n , of the detector transformer, T , and the voltage, V_p , required at the vertical input of the oscilloscope to produce a vertical deflection of the same magnitude as that produced by the discharges. Measure V_p directly by connecting a peak-to-peak voltmeter across the vertical input of the oscilloscope as shown in Fig. 2, and read when the parallelogram is obtained. Then:

$$Q_t = nV_p C_4 \quad (5)$$

where Q_t is the total charge per half cycle, or

$$S_y = nV_p C_4/D_y \quad (6)$$

where D_y is the height of the parallelogram in centimetres.

13. Calculation

13.1 *Integrated Charge*—The integrated-charge transfer per half cycle, Q_t , is the product of the vertical deflection, D_y , of the oscilloscope (the height of the parallelogram) multiplied by the vertical-deflection sensitivity S_y :

$$Q_t = D_y S_y \quad (7)$$

13.2 *Energy*—The energy, W , in joules per cycle, is the area, A , of the parallelogram measured in the same units as the deflection sensitivities:

$$W = AS_x S_y \quad (8)$$

Where the parallelogram is well defined, the area is the product of the parallelogram heights, D_y , and the width, D_{xi} , conveniently measured along the center axis of the oscilloscope raster. Thus

$$W = D_{xi} D_y S_x S_y \quad (9)$$

13.3 *Capacitance Increase*—The increase, ΔC , of the specimen capacitance with voltage, from the voltage below the discharge inception, where the bridge is initially balanced, up to the test voltage is:

$$\Delta C = Q_t/V_a \quad (10)$$

where V_a is the applied peak-to-peak voltage at which the test is being made. This voltage corresponds to the total horizontal projected width of the parallelogram.

13.4 For further analysis of measurements see [Annex A3](#).

14. Report

14.1 Report the following information:

14.1.1 *Identification*—Include information that describes the specimen, so as to permit comparison between similar systems or different production lots of the same system, and to permit other types of comparison between different materials,

14.1.2 *Test Method*—Include a description of the test procedure, test apparatus, test specimen, the test voltages and length of time applied, preconditioning and history, and ambient conditions and any other factors that has the potential to influence the performance of the test and the result obtained, and that will permit exact duplication of the tests at a later time,

14.1.3 Date of test,

14.1.4 Where tests were performed and by whom,

14.1.5 *Test Results*—Include experimental values obtained, number of specimens tested, along with results from appropriate calculations such as average (mean), standard deviation, etc., and

14.1.6 *Observations*—Include information of importance to the understanding or interpretation of the test method and results that have not been included in the foregoing sections.

15. Precision and Bias

15.1 This test method has been in use for many years, but no statement for precision has been made and no activity is planned to develop such a statement.

15.2 A statement of bias is not possible due to the lack of a standard reference material.

16. Keywords

16.1 bridge circuits; bridge techniques; capacitance increase; charge-voltage-trace bridge; corona; discharge energy; discharge inception level; energy; harmonics; integrated charge transfer; internal discharges; ionizing voltage; loop trace; partial discharges; pseudoglow discharge; pulse discharge; pulseless-glow discharge; pulse measurements; solid insulating materials; surface discharge; transformer-ratio-arm bridge

ANNEXES

(Mandatory Information)

A1. LIST OF SYMBOLS

A	area of parallelogram, also amplifier	n	turn ratio of transformer T , see Fig. 2
A_m	measured area of parallelogram	P	power, Test Method B
C_1, C_2, C_3, C_4	capacitances, see Fig. 2	P_1	low-voltage power, Test Method A
C_2	capacitance, see Fig. 1	P_2	high-voltage power, Test Method A
C_x	specimen capacitance	ΔP	power increment, Test Method A
C_{x1}	specimen capacitance, low voltage, Test Method A	Q_t	total charge per half cycle, see Fig. 3
C_{x2}	specimen capacitance, high voltage, Test Method A	R_2, R_4, R_H, R_L	resistances, see Fig. 2
C_x'	specimen capacitance, high voltage, Test Method B	R_2	resistance, see Fig. 1
ΔC	specimen-capacitance increment, Test Method B, see Fig. 3	R_x	specimen resistance, see Fig. 1
C_{+}, C_L	capacitances, see Fig. 2	S_x	CRO x-axis sensitivity, see Fig. 3
C_c	calibrating capacitor	S_y	CRO y-axis sensitivity, see Fig. 3
C_s	standard capacitor, see Fig. 1 and Test Methods D150, Fig. X4.2	T	transformer, see Fig. 2
D_{xi}	CRO deflection, x-axis at discharge inception voltage, see Fig. 3	V_t	supply voltage, see Fig. 2
D_{xa}	CRO deflection, x-axis at applied voltage above inception, see Fig. 3	V_1	low voltage, Test Method A
D_y	CRO deflection, y-axis, see Fig. 3	V_2	high voltage, Test Method A
E_c	square-wave-generator voltage, peak-to-peak, see Eq 4	V_a	applied voltage above discharge inception, Test Method B
f	frequency	V_c	applied voltage at discharge inception, Test Method B
ND	null detector, see Fig. 1	V_p	calibrating voltage, Test Method B, see 11.3
		W	work, energy, Test Method B
		W_1, W_2, W_3	transformer turns, see Fig. 1
		ω	$2\pi f$
		δ	dielectric loss angle

A2. CIRCUIT COMPONENTS AND MEASUREMENT PROCEDURE FOR TEST METHOD B
(SEE Fig. 2)

A2.1. Apparatus

A2.1.1 *Bridge*—The bridge shown in Fig. 2 consists of four essentially capacitive arms. There are two high-voltage arms, as in a high-voltage, Schering-type bridge. One of these, C_x (or C_2), is the specimen to be measured. The second, C_1 , is a high-voltage discharge-free capacitor, usually a 100-pF standard capacitor, with $\tan \delta < 0.001$. The two low-voltage arms, C_3 and C_4 , are capacitance arms, used for balancing the bridge at a voltage just below the discharge-inception voltage. The unbalance voltage above the discharge-inception voltage is proportional to the sum of the discharges in the specimen per half cycle, provided that certain precautions are taken. The unbalance voltage of the bridge is displayed on the vertical axis of an oscilloscope, and the horizontal axis is driven by a voltage proportional to, and in phase with, the high voltage applied to the bridge. The oscilloscope display properly consists of a horizontal line at balance below the discharge-inception voltage. Above the discharge-inception voltage, the display breaks into an approximate parallelogram, with small steps on each sloping side, but with a flat, smooth trace on the top and bottom. The sloping sides of the parallelogram are the

discharging portion of the voltage cycle, and the top and bottom are the nondischarging portions of the cycle.

A2.1.2 Normal losses in the specimen are balanced by a variable resistor, R_1 , in series with C_1 . A convenient range for R_1 is from 0 to 1 M Ω . Further balance is provided by variable resistor R_4 in parallel with C_4 . Resistor R_4 also functions to control the average voltage level across C_4 , which might rise to unacceptable values if the discharges of one polarity recurrently exceed those of the other polarity. Resistor R_4 shall have a sufficiently high value to avoid any significant drain on the charge accumulated on C_4 during one half cycle of the test voltage. Thus $R_4 C_4 > 100/f$ where f is the frequency of the test voltage.

A2.1.3 The loss tangents of variable capacitors C_3 and C_4 need to preferably be less than 0.0001. If greater than 0.0001, and unequal in value, their loss tangents will have to be compensated for by adjustment of R_4 and R_1 . In this latter case, it would not be possible to calculate the loss tangent of C_x from the values of R_1 and C_2 or R_4 and C_4 .

A2.1.4 Transformer T shall have a ratio near unity (3/1 has been used), with the primary having the most turns. The primary shall have a 60-Hz impedance greater than 0.2 M Ω .

A2.2 High-Voltage Divider

A2.2.1 A high-voltage divider consisting of either resistors or series capacitors, giving a negligible phase shift, is required. Since it is desirable to have a maximum voltage of 100 V across the low-voltage series element at the highest test voltage, V_t , the following condition shall be met: $(R_L/R_H) V_t < 100$ or $(C_H/C_L) V_t < 100$, where $V_t = V_a/2\sqrt{2} \cdot R_H$ or C_H shall be selected to withstand the highest test voltage and frequency without excessive heating or corona. The phase angle of R_L and R_H , or C_H and C_L , shall be the same within 1 %.

A2.3 Oscilloscope

A2.3.1 An oscilloscope with vertical, y , and horizontal, x , inputs which are adjustable, is used. The sensitivity of the vertical input needs to preferably be 1 mV/cm or better, with calibrated sensitivity. (It is desirable and convenient to connect a peak-reading meter in parallel with the vertical input to the oscilloscope to read the vertical deflection more conveniently.)

A2.4 High-Voltage Transformer

A2.4.1 The high-voltage transformer shall supply a test voltage with low harmonic content. It will potentially be necessary to filter the test voltage to reduce the harmonic content, especially when low-energy discharges are to be measured. A capacitor (C_2) in Fig. 2, having a capacitance large in comparison with that of the test specimen, shall be connected across the high-voltage winding of the transformer to permit the transfer of discharges from the test specimen C_x to the integrating capacitor C_4 .

A2.5. Measurement Procedure

A2.5.1 Connect the specimen, C_x , in the bridge, as indicated in Fig. 2. Raise the applied voltage to 500 to 1000 V (rms), which is usually below the discharge-inception voltage. With thick specimens, higher voltages are acceptable for use. With very thin specimens, it will potentially be necessary to stay

below 300 V to obtain an initial balance. In balancing the bridge, element C_4 is usually set first so as to achieve maximum sensitivity without exceeding 100 V on the element $C_4 > (V_t/100) C_x$. This requires a knowledge of the approximate capacitance of the specimen. If this is not known, choose a safe high value of C_4 for a preliminary balance. Calculate the value of C_x as follows:

$$C_x = (C_1 C_4 / C_3), \quad (\text{A2.1})$$

and reset C_4 for a second balance. Balance the capacitance by adjusting C_3 after C_4 is set. Balance the $\tan \delta$ of the specimen by adjusting R_4 or R_1 .

A2.5.2 After initial low-voltage balance is achieved, raise the voltage to selected levels above the discharge-onset voltage, which is evident from a sudden change in the oscilloscope trace from a nearly horizontal line to an open (approximate) parallelogram with step sides. Whether or not the steps are apparent depends on the detector sensitivity and the ratio of individual pulse-discharge size to the sum of these per cycle.

A2.5.3 When the voltage is raised above the discharge-onset voltage the parallelogram figure will sometimes tilt so as to have sloping top and bottom sides or develop a curved top. This is due to changing $\tan \delta$ or capacitance of the solid (or liquid) insulation of the specimen with voltage, not due to discharges. If this happens, it is possible that a small adjustment in C_3 , R_1 , or R_4 will correct the orientation and curvature so that the top and bottom are horizontal and flatter.

A2.5.4 In Annex A3 an equation (Eq A3.7) is given for $\Delta \tan \delta$ that involves a magnitude of C_x at some value of V_a above V_c . It is identified as C_x' in Eq A3.7. It can be determined by repeating the procedure given in A2.5.1 at V_1 , that is:

$$C_x' = C_1 C_4 / C_3 \quad (\text{A2.2})$$

or

$$C_x' = C_x + \Delta C \quad (\text{A2.3})$$

where C_x was initially determined as in A2.5.1, and ΔC determined as shown in Fig. 3.

A3. ADDITIONAL MEASUREMENT ANALYSIS (TEST METHOD B)

A3.1 Referring to Fig. 3, and based on the equations given in Sections 12 and 13, the measurement can be further analyzed as follows:

$$P, \text{ watts} = fW = (\omega/2\pi)W \quad (\text{A3.1})$$

$$W, \text{ joules/cycle} = D_{xi} D_y S_x S_y \quad (\text{A3.2})$$

$$P, \text{ watts} = (\omega/2\pi) D_{xi} D_y S_x S_y \quad (\text{A3.3})$$

A3.2 The ideal shape of the parallelogram shown in Fig. 3 by the solid lines applies to cases where the discharge onset in all cavities occurs at the same value of applied voltage. In

practical insulating systems, cavities generally have unequal breakdown or ionization voltages, with the result that at partial-discharge onset not all cavities necessarily undergo ionization. Therefore, as the applied voltage is increased, more cavities begin to discharge, and this effect causes smooth curvatures of the parallelogram corners as shown by the dashed lines in contrast to the sharp corners of the idealized trace shown in Fig. 3. As a result, when a certain degree of accuracy is required, (Eq 1) and (Eq 4) or (Eq 5) cannot be used to calculate energy by (Eq 7). Instead, the discharge-energy-loss

per cycle must be determined by using a planimeter or other area measuring device of equal or greater precision to obtain the area, A_m , of the trace. This procedure will constitute a direct measure of the discharge energy and power loss, that is:

$$W = A_m S_y S_x \quad (\text{A3.4})$$

$$P = (\omega/2\pi) A_m S_y S_x \quad (\text{A3.5})$$

A3.3 It is sometimes desirable to determine the effect of discharges on the dissipation factor, $\Delta \tan \delta$. For the idealized case (Fig. 3):

$$\Delta \tan \delta = 8P/\omega C_x' V_a^2 \quad (\text{A3.6})$$

where $C_x' = C_x + \Delta C$ (see A2.5.4)

$$\Delta \tan \delta = 8\omega A S_y S_x / 2\pi \omega C_x' V_a^2 = 4W/\pi C_x' V_a^2 \quad (\text{A3.7})$$

Where the area of the parallelogram needs to be measured, A in Eq A3.7 shall be replaced with A_m .

REFERENCES

- (1) Bartnikas, R., "Some Observations on the Character of Corona Discharges in Short Gap Spaces," IEEE Trans. on Electrical Insulation, Vol.6, June 1971, pp. 63-75.
- (2) Kasten, D.G., Liu, X., Sebo, S.A., Grosjean, D.F., and Schweickart, D.L., "Partial Discharge Measurements in Air and Argon at Low Pressures with and without a Dielectric Barrier," IEEE Trans. on Dielectrics and Electrical Insulation, Vol.12, 2005, pp. 362-373.
- (3) Bartnikas, R., and Novak, J.P., "On the Character of Different Forms of Partial Discharge and their Related Terminologies," IEEE Trans. on Dielectrics and Electrical Insulation, Vol. 28, 1993, pp. 956-968.
- (4) Bartnikas, R., "Pulsed Corona Loss Measurements in Artificial Voids and Cables," Proc.CIGRE, Report 202, Paris, 1966, pp. 1-37.
- (5) Dakin, T.W., and Malinaric, P.J., "A Capacitance Bridge Method for Measuring Corona Charge Transfer and Power Loss per Cycle," IEEE Trans. on Power Apparatus and Systems, Vol. 79, 1960, pp. 648-653.
- (6) Bartnikas, R., and McMahon, E.J., Engineering Dielectrics, Vol. I, Corona Measurement and Interpretation, ASTM STP 669, ASTM, 1979. (www.astm.org/digitallibrary)
- (7) Dakin, T.W., "The Relation of Capacitance Increase with High Voltages to Internal Discharges and Discharging Void Volume," AIEE Trans. on Power Apparatus and Systems, Vol. 78, 1959, pp. 790-795.
- (8) Symposium on Corona, ASTM STP 198, ASTM, 1956. (www.astm.org/digitallibrary)

SUMMARY OF CHANGES

Committee D09 has identified the location of selected changes to these test methods since the last issue, D3382 – 07, that may impact the use of these test methods. (November 1, 2013)

(I) Revised non mandatory language.

Committee D09 has identified the location of selected changes to these test methods since the last issue, D3382 – 95(2001)^{e1}, that may impact the use of these test methods.

(I) Revised Sections 1, 3, 5, 8, and 11.

ASTM International takes no position respecting the validity of any patent rights asserted in connection with any item mentioned in this standard. Users of this standard are expressly advised that determination of the validity of any such patent rights, and the risk of infringement of such rights, are entirely their own responsibility.

This standard is subject to revision at any time by the responsible technical committee and must be reviewed every five years and if not revised, either reapproved or withdrawn. Your comments are invited either for revision of this standard or for additional standards and should be addressed to ASTM International Headquarters. Your comments will receive careful consideration at a meeting of the responsible technical committee, which you may attend. If you feel that your comments have not received a fair hearing you should make your views known to the ASTM Committee on Standards, at the address shown below.

This standard is copyrighted by ASTM International, 100 Barr Harbor Drive, PO Box C700, West Conshohocken, PA 19428-2959, United States. Individual reprints (single or multiple copies) of this standard may be obtained by contacting ASTM at the above address or at 610-832-9585 (phone), 610-832-9555 (fax), or service@astm.org (e-mail); or through the ASTM website (www.astm.org). Permission rights to photocopy the standard may also be secured from the Copyright Clearance Center, 222 Rosewood Drive, Danvers, MA 01923, Tel: (978) 646-2600; <http://www.copyright.com/>