



Standard Test Method for Flow Rates for Poly(Vinyl Chloride) with Molecular Structural Implications¹

This standard is issued under the fixed designation D3364; the number immediately following the designation indicates the year of original adoption or, in the case of revision, the year of last revision. A number in parentheses indicates the year of last reapproval. A superscript epsilon (ϵ) indicates an editorial change since the last revision or reapproval.

1. Scope

1.1 This test method is an extension of Test Method D1238 specific to the measurement of flow rates of poly(vinyl chloride) (PVC) compounds while detecting and controlling various polymer instabilities associated with the flow rate.

1.2 The values stated in SI units are to be regarded as standard. The values given in parentheses are mathematical conversions to inch-pound units that are provided for information only and are not considered standard.

1.3 *This standard does not purport to address all of the safety concerns, if any, associated with its use. It is the responsibility of the user of this standard to establish appropriate safety and health practices and determine the applicability of regulatory limitations prior to use.*

NOTE 1—There is no known ISO equivalent to this standard.

2. Referenced Documents

- 2.1 *ASTM Standards*:²
 - D883 Terminology Relating to Plastics
 - D1238 Test Method for Melt Flow Rates of Thermoplastics by Extrusion Plastometer
 - D3835 Test Method for Determination of Properties of Polymeric Materials by Means of a Capillary Rheometer
 - E177 Practice for Use of the Terms Precision and Bias in ASTM Test Methods
 - E691 Practice for Conducting an Interlaboratory Study to Determine the Precision of a Test Method

3. Terminology

3.1 *Definitions*—For definitions related to plastics, see Terminology D883.

3.2 *Definitions of Terms Specific to This Standard*:

¹ This test method is under the jurisdiction of ASTM Committee D20 on Plastics and is the direct responsibility of Subcommittee D20.30 on Thermal Properties.

Current edition approved Sept. 1, 2011. Published October 2011. Originally approved in 1974. Last previous edition approved in 2004 as D3364 - 99 (2004). DOI: 10.1520/D3364-99R11.

² For referenced ASTM standards, visit the ASTM website, www.astm.org, or contact ASTM Customer Service at service@astm.org. For *Annual Book of ASTM Standards* volume information, refer to the standard's Document Summary page on the ASTM website.

3.2.1 See Test Method D3835, Sections 5.1, 5.2, and 5.3.

3.2.2 *Flow* is the reciprocal of the viscosity; therefore, the flow is defined as the volumetric displacement through a controlled orifice and is expressed as shear rate over shear stress.

NOTE 2—Since PVC obeys the power law function, the above relationship can be expressed as follows:

(Viscosity) (Shear Rate)^{1-N} = (shear stress) in which the shear rate is expressed as $4Q/\pi R^3$ and depends on the power law exponent N .

Since Q is the volumetric flow rate in terms of cubic millimetres/second and R is the radius of the die, it follows that the flow rate varies much faster than the viscosity as a result of N . This means that the flow is much more sensitive to change than the viscosity. For PVC, N varies from 0.1 to 0.33.

3.2.3 Flow rate by this test method is the rate in milligrams/minute at which polymer flows through a specific die (see Fig. 1) with a total load on the ram of 20 kg at a temperature of 175°C.

4. Summary of Test Method

4.1 Conditions:

4.1.1 In order to test a wide variation of flow rates covering semirigid as well as nonrigid PVC compounds, the following standard conditions are used:

Temperature	175°C (347°F)
Total load on piston	20 000 g
Approximate pressure	2758 kPa (400 psi)
Charge	2.15 ± 0.05 g
Plugged orifice with 120° entrance angle	

4.2 Basis Principles:

4.2.1 The lower temperature (relative to 190°C) is chosen to minimize thermal decomposition, maximize sensitivity of the flow rate to structural changes in the PVC compound, and to allow a wide latitude of useful conditions associated with the load on the piston.

4.2.2 Modern extrusion plastometers have been redesigned to accommodate much higher loads. Current research for multi-weight testing has reached levels of 50 kg and these are particularly good for rigid PVC. Previously, flow rates for rigid PVC were limited to 190°C. Recent research has shown that rigid PVC can be run at 150°C and 50 kg loads. This weight is effective for all semirigid PVC and even some nonrigid compounds. For flow rates in excess of 10 g/10 min (1000

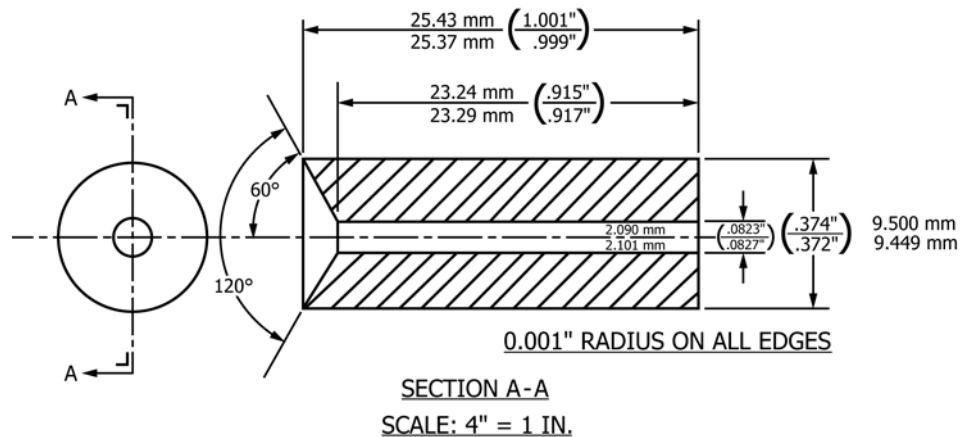

NOTE 1—Specify material when ordering.
FIG. 1 Die Used for Test Method D3364

mg/min), lower weights are used, for example, color concentrates used in PVC extrusion may have flow rates in excess of 100 g/10 min (10 000 mg/min) and will require a 5-kg load on the piston.

4.2.3 When the flow rates become very small as in the case of the stiffest semirigid containing 25 parts of plasticizer (flow rates below 15 mg/min), it may be desirable to use the die (flat entry 8 mm (0.315 in.) long) in Test Method **D1238**. The flow is so slow that little rheological instability exists. By changing the die, approximately a tenfold increase in flow is achieved.

4.2.4 The charge size is important. Many PVC compounds are elastic in nature, causing a severe loss in pressure from the bottom of the piston through the material to the orifice of the die. Evidence indicates that the force to extrude may be reduced by as much as 67 % using a 9-g charge and 4.14 MPa (600 psi) on the piston.

4.2.5 The plugged orifice should be used in all PVC compound work since the amount of charge is limited and since the plugging for various times has been observed to give significant variations in the flow rate.

5. Significance and Use

5.1 This test method is useful for quality-control tests on PVC compounds having a wide range of melt viscosities. Measurements are made at shear rates close to 1 s^{-1} .

5.2 In addition to the properties mentioned in Test Method **D1238**, this technique is sensitive to plasticizer content, polymer molecular weight, polymer stability (both thermally and rheologically), shear instability, and general composition. The sensitivity of the material to temperature necessitates slightly tighter controls than those stated in Test Method **D1238**.

5.3 The sensitivity of this test method makes it useful for correlating with processing conditions and as an aid in predicting changes in processing. However, as a one-point measure of flow relative to shear rate, its one drawback is that the same PVC melt flow values can be obtained for materials having different processibility; the chance of this happening is minimized, however, if the compounds are similar in composition.

5.4 Correlations with a wide range of processing conditions have supported the conclusions that little or no change in composition occurs during the test. Thus, this test is able to detect and follow profound changes which occur during extrusion, injection molding, milling, or mixing. These changes are due to three types of measured instability in polymers:

- 5.4.1 Thermal instability due to temperature effect.
- 5.4.2 Shear instability due to breaking of polymer bonds.
- 5.4.3 Rheological instability due to nonuniform distributions of widely different viscosity or molecular weight elements.

5.4.4 Thus, implications with respect to PVC molecular structural changes can be detected and predicted.

6. Apparatus

6.1 *Plastometer*—The apparatus is identical to that used in Test Method **D1238** except for the die. An alternative thermoregulator is suggested for improved temperature control.

6.2 Die:

6.2.1 The die is approximately three times as long as the one used in Test Method **D1238**, a major factor in controlling any rheological instability in the polymer. If instability still occurs, particularly at high flow rates, dies 2 in. or longer can be used to improve the L/D ratio. The dimensions of the regular die are shown in **Fig. 1**.

6.3 *Thermoregulator*—Although a thermoregulator identical to that used in Test Method **D1238** may be used (provided it regulates to $175 \pm 0.1^\circ\text{C}$), a unit³ coupled with a 90° angle thermometer, divided into 0.1°C is suggested for improved reproducibility. Most regulators designed for Test Method **D1238** cannot control better than $\pm 0.2^\circ\text{C}$. The sensitivity of this test method is illustrated by the fact that a 19 % change in flow rate is observed on a typical PVC compound with a 1°C change in temperatures.

³ The “Thermo Watch” unit, manufactured by Instruments for Research and Industry, 103 Franklin Ave., Cheltenham, PA 19012, has been found satisfactory for this purpose.

TABLE 1 Time Requirements for Cutting Specimens

Flow Rate Range, mg/min	Time Interval Between Cuts	Typical Type
15 to 30	4 min	semirigid
30 to 50	2 min	semirigid
50 to 100	1 min	semirigid
100 to 500	30 s	nonrigid
400 to 1500	15 s	nonrigid
1000 to 2000	10 s	soft

6.4 *Thermometer*, measuring the standard temperature, should rest on the top of the orifice to conform with conditions in accordance with Test Method **D1238** (½ in. above the shorter orifice).

7. Procedure

7.1 Check that the temperature is controlled to $\pm 0.1^\circ\text{C}$ in the range from 174.9 to 175.1°C.

7.2 The apparatus must be clean.

7.3 With the die in place, plug the orifice (a sharpened wood dowel is a satisfactory plug).

7.4 Allow the die and plug to heat at least 3 min.

7.5 Start the stopwatch and charge 2.15 ± 0.05 g of the PVC compound into the bore. When charging is complete, pack down the PVC with the phenolic-coated charging tool by repeated thrusts.

7.6 Place the piston in the bore and add sufficient weights to make the total mass including the piston equal to $20 \text{ kg} \pm 10$ g. The entire time of charging and positioning of weights should take no longer than 1 min and preferably less than ½ min. If charging time is greater than 1 min, clean out the instrument and repeat the procedure.

7.7 When the stopwatch reads exactly 360 s (6 min), pull the plug from the orifice.

7.8 At this time (6 min) and without stopping the stopwatch, cut off the extruded portion very cleanly with the spatula exactly when the second hand of the watch reaches zero. Pass the tip of the spatula upward along one side of the beveled hole, lightly across the bottom of the orifice, and downward along the opposite side. Make the cut quickly and neatly for best precision. A clean sharp cut is desirable so that succeeding portions will extrude straight, not curled. It may be necessary to reshape the end of the cutoff tool to obtain the best results.

7.9 The time for cutting the specimen shall be in accordance with **Table 1**. As a guide, each specimen should be about 20 to 30 mm long.

7.10 Place the cut specimen in the slotted tray in the order taken.

7.11 Continue to take specimens up to and including 42 min or until flow stops, whichever is sooner.

7.12 Weigh and record the results to the closest 1 mg. Average the five successive most stable values near the end of the run and express as milligrams per minute. This average value is the PVC flow rate. Do not use the first two or last two values since these are normally unstable values.

TABLE 2 Measurement Conversion to Milligrams per Minute

Time Interval, min	Factor for Obtaining Flow Rate in mg/min Multiply By
4	0.25
2	0.50
1	1.00
0.50 (30 s)	2.00
0.25 (15 s)	4.00
0.167 (10 s)	6.00

NOTE 3—Occasionally, the values change throughout the run. This may be due to variable lubricant conditions at the metal surfaces or chemical changes in the PVC compound. Under these conditions, average the values after discarding the first three values and the last two. The cause of this unstable condition should be studied and understood.

7.13 Of the five stable specimens, subtract the weight of the fifth from that of the first. Divide the difference by the average and multiply by 100. Report as percent PVC instability. Fluctuations up and down repeatedly during a run can indicate nonuniform mixing or a bad charging technique.

7.14 Determine the diameter of the extrudate for the first and fifth stable specimens with a micrometer. If the difference between the two specimens is greater than 0.15 mm (0.006 in.) (the normal PVC swell, observed for a wide range of PVC compounds), report the total difference as PVC swelling instability. Be careful not to squeeze the specimen; the specimen should fit the micrometer setting easily, but not quite fall free.

7.15 Remove the weights and piston, and clean the piston with a cloth.

7.16 Push the die out of the top of the cylinder with the push-out tool. Push out any molten PVC in the orifice with the orifice broach. Put the die (hot) into methyl ethyl ketone in order to break the PVC skin away from the orifice. Dry off the cooled die with a cloth and inspect to see that the orifice is clean. At least twice a day check the orifice with the “go-no-go” gage.

7.17 Clean up the cylinder, replace the die, and insert the plug. The instrument is now ready for the next test. Return to **7.4**.

8. Calculation

8.1 The simple average of the five values is first posted as the milligrams per time scale. The PVC melt flow value is then obtained by adjusting the value to milligrams per minute (see **Table 2**).

8.2 The instability is measured by subtracting the weight of the fifth or last specimen from the first specimen. The value for the instability will then be positive or negative. Thus,

$$\begin{array}{r} 200 \text{ mg}/15 \text{ s} \quad 4\text{th specimen} \\ 250 \text{ mg}/15 \text{ s} \quad 9\text{th specimen} \end{array}$$

TABLE 3 Summary of Precision Parameters (Values Expressed in Units of Milligrams per Minute)

Material	Average	S_r^A	S_R^B	r^C	R^D
Semirigid	108	3.05	8.00	8.53	22.39
Flexible	293	13.86	31.59	38.80	88.45
Flexible	439	13.58	35.48	38.04	99.35

^A S_r = within-laboratory standard deviation of the average (median/other function).

^B S_R = between-laboratories standard deviation of the average (median/other).

^C r = within-laboratory repeatability limit = 2.8 S_r .

^D R = between-laboratories reproducibility limit = 2.8 S_R .

8.3 Calculate the simple average and the instability value as follows:

$$\text{instability} = -50 \text{ mg/15 s} \quad (1)$$

$$\text{average} = 225 \text{ mg/15 s}$$

$$\frac{-50}{225} = -22.2\%$$

where:

$$\text{instability} = \frac{FR_4 - FR_9}{\text{average } FR} \times 100,$$

FR_4 = flow rate of 4th specimen, and

FR_9 = flow rate of 9th specimen.

NOTE 4—A positive instability probably indicates that crosslinking is occurring. A negative instability indicates either a degradation of the polymer or a change in the lubricant function at the metal surface of the die.

9. Report

9.1 Report the following information:

9.1.1 PVC flow rate, stating the date, any process information, sample identification, weight on the piston, and die,

9.1.2 Percent PVC instability,

9.1.3 PVC swelling instability, and

9.1.4 Any change in color, referenced to the time at which it occurred.

10. Precision and Bias

10.1 *Precision:*

10.1.1 **Table 3** is based on a round robin⁴ conducted in 1991 in accordance with Practice **E691**, involving three materials tested by seven laboratories. For each material, all the samples were prepared at one source, but the individual specimens were prepared at the laboratories which tested them. Each test result

⁴ The round-robin data supporting these values may be obtained from ASTM Headquarters. Request RR:D20-1042.

was the average of five individual determinations. Each laboratory obtained three test results for each material. (**Warning**— The following explanations of r and R (**10.1.2 – 10.1.2.3**) are intended only to present a meaningful way of considering the approximate precision of this test method. The data in **Table 3** should not be rigorously applied to acceptance or rejection of material, as those data are specific to the round robin and may not be representative of other lots, conditions, materials, or laboratories. Users of this test method should apply the principles outlined in Practice **E691** to generate data specific to their laboratory and materials, or between specific laboratories. The principles of **10.1.2 – 10.1.2.3** would then be valid for such data.)

10.1.2 *Concept of r and R* —If S_r and S_R have been calculated from a large enough body of data and for test results that were averages from testing five specimens, the following applies:

10.1.2.1 *Repeatability Limit, r* —In comparing two test results for the same material obtained by the same operator using the same equipment on the same day, the two test results should be judged not equivalent if they differ by more than the r value for that material.

10.1.2.2 *Reproducibility Limit, R* —In comparing two test results for the same material obtained by different operators using different equipment in different laboratories, the two test results should be judged not equivalent if they differ by more than the R value for that material.

10.1.2.3 Any judgment made in accordance with **10.1.2.1** or **10.1.2.2** would have an approximate 95 % (0.95) probability of being correct.

10.1.2.4 Experience has shown that the single-laboratory precision can be improved by a factor of two or more by careful operator control of the systematic errors such as the dimensions of the components of the melt indexer, when truly uniform samples are used for the determinations, and when the operator becomes experienced in observing differences in a single formulated compound. This statement further defines the repeatability of this measurement in accordance with Practice **E177**.

10.2 *Bias*—The procedure in this test method has no bias because the value of the melt flow rate is defined only in the terms of the test method.

11. Keywords

11.1 chain shearing; crosslinking; degradation; fragmentation; melt flow rate; poly(vinyl chloride); rheology; shear instability

 **D3364 – 99 (2011)**

ASTM International takes no position respecting the validity of any patent rights asserted in connection with any item mentioned in this standard. Users of this standard are expressly advised that determination of the validity of any such patent rights, and the risk of infringement of such rights, are entirely their own responsibility.

This standard is subject to revision at any time by the responsible technical committee and must be reviewed every five years and if not revised, either reapproved or withdrawn. Your comments are invited either for revision of this standard or for additional standards and should be addressed to ASTM International Headquarters. Your comments will receive careful consideration at a meeting of the responsible technical committee, which you may attend. If you feel that your comments have not received a fair hearing you should make your views known to the ASTM Committee on Standards, at the address shown below.

This standard is copyrighted by ASTM International, 100 Barr Harbor Drive, PO Box C700, West Conshohocken, PA 19428-2959, United States. Individual reprints (single or multiple copies) of this standard may be obtained by contacting ASTM at the above address or at 610-832-9585 (phone), 610-832-9555 (fax), or service@astm.org (e-mail); or through the ASTM website (www.astm.org). Permission rights to photocopy the standard may also be secured from the Copyright Clearance Center, 222 Rosewood Drive, Danvers, MA 01923, Tel: (978) 646-2600; <http://www.copyright.com/>