



Standard Test Method for Film Hardness by Pencil Test¹

This standard is issued under the fixed designation D3363; the number immediately following the designation indicates the year of original adoption or, in the case of revision, the year of last revision. A number in parentheses indicates the year of last reapproval. A superscript epsilon (ε) indicates an editorial change since the last revision or reapproval.

This standard has been approved for use by agencies of the U.S. Department of Defense.

¹ NOTE—Figure 1 was corrected editorially in August 2011.

^{ε2} NOTE—Figure 2 and Section 7 were corrected editorially in March 2012.

1. Scope*

1.1 This test method covers a procedure for rapid, inexpensive determination of the film hardness of an organic coating on a substrate in terms of drawing leads or pencil leads of known hardness.

1.2 This test method is similar in content (but not technically equivalent) to ISO 15184.

1.3 The values stated in SI units are to be regarded as the standard. The values given in parentheses are for information only.

1.4 *This standard does not purport to address all of the safety concerns, if any, associated with its use. It is the responsibility of the user of this standard to establish appropriate safety and health practices and determine the applicability of regulatory limitations prior to use.*

2. Referenced Documents

2.1 Other Standards:

ISO 15184 Determination of film hardness by pencil test.²

3. Summary of Test Method

3.1 A coated panel is placed on a firm horizontal surface. The pencil is held firmly against the film at a 45° angle (point away from the operator) and pushed away from the operator in a 6.5-mm (1/4-in.) stroke. The process is started with the hardest pencil and continued down the scale of hardness to either of two end points: one, the pencil that will not cut into or gouge the film (pencil hardness), or two, the pencil that will not scratch the film (scratch hardness).

¹ This test method is under the jurisdiction of ASTM Committee D01 on Paint and Related Coatings, Materials, and Applications and is the direct responsibility of Subcommittee D01.23 on Physical Properties of Applied Paint Films.

Current edition approved June 1, 2011. Published June 2011. Originally approved in 1974. Last previous edition approved in 2005 as D3363 – 05. DOI: 10.1520/D3363-05R11E02.

² Available from American National Standards Institute (ANSI), 25 W. 43rd St., 4th Floor, New York, NY 10036, <http://www.ansi.org>.

4. Significance and Use

4.1 Pencil hardness measurements have been used by the coatings industry for many years to determine the hardness of clear and pigmented organic coating films. This test method has also been used to determine the cure of these coatings, especially when forced dried using heat.

4.2 This test method is especially useful in developmental work and in production control testing in a single laboratory. It should be recognized that the results obtained may vary between different laboratories when different pencils as well as panels are used. Every effort should be made to standardize the hardness of the lead used and the technique followed.

4.3 If this test method is used as a basis for purchase agreement, maximum precision will be achieved if a given set of referee pencils be agreed upon between the purchaser and the seller.

5. Apparatus

5.1 A set of calibrated drawing leads (preferred) or equivalent calibrated wood pencils meeting the following scale of hardness:

$$\frac{6B-5B-4B-3B-2B-B-HB-F-H-2H-3H-4H-5H-6H}{\text{Softer} \qquad \qquad \qquad \text{Harder}} \quad (1)$$

The difference between two adjacent leads shall be considered one unit of hardness.

5.2 *Mechanical Lead Holder*, for drawing leads if used.

5.3 *Mechanical Sharpener*, draftsman-type, is helpful for trimming wood pencils if used.

5.4 *Abrasive Paper*, grit No. 400.

6. Test Specimens and Conditions

6.1 Apply the surface coating by appropriate means to a smooth rigid substrate and cure properly, or use representative panels cut from coated stock. The panels used, the curing conditions, and the age of the coating prior to the test shall be within the limits agreed upon between the purchaser and the seller.

*A Summary of Changes section appears at the end of this standard

6.2 The film thickness of the coating shall be as specified or as agreed upon between the purchaser and the seller.

6.3 Conduct the test at $23 \pm 2^\circ\text{C}$ ($73.5 \pm 3.5^\circ\text{F}$) and $50 \pm 5\%$ relative humidity.

7. Procedure

7.1 For wood pencils, remove approximately 5 to 6 mm ($\frac{3}{16}$ to $\frac{1}{4}$ in.) of wood from the point of each pencil using a draftsman-type mechanical sharpener, being careful to leave an undisturbed, unmarked, smooth cylinder of lead. Holding the pencil holder (when using drawing leads) at an angle of 90° to the abrasive paper, rub the lead against the paper maintaining an exact angle of 90° to the abrasive paper until a flat, smooth and circular cross section is obtained, free of chips or nicks in the edge of the cross section. For wood pencils, see Fig. 1 for an illustration. For mechanical pencil holders with drawing leads, see Fig. 2 as the illustration. The desired edge may be obtained by cementing the abrasive paper to a flat motor-driven disk. By supporting the pencil at 90° to the rotating disk a uniform flat lead end may be obtained more reproducibly.

7.2 Place the coated panel on a level, firm, horizontal surface. Starting with the hardest lead, hold the pencil or lead holder firmly with the lead against the film at a 45° angle (point away from the operator) and push away from the operator. Exert sufficient uniform pressure downward and forward either to cut or scratch the film or to crumble the edge of the lead. It is suggested that the length of the stroke be 6.5 mm ($\frac{1}{4}$ in.).

7.3 Repeat the process down the hardness scale until a pencil is found that will not cut through the film to the substrate (either metal or a previous coat) for a distance of at least 3 mm ($\frac{1}{8}$ in.) (see 8.1.1).

NOTE 1—The operator must watch closely for cutting into or scratching the film. Some finishes contain compounds that may tend to lubricate the film. Checks should be made by close visual inspection and by fingernail feel.

NOTE 2—In conducting the test, if the sharp edge of the lead is slightly chipped or crumbled, the lead must be resharpened.

7.4 Continue the process until a pencil is found that will neither cut through nor scratch the surface of the film. Any defacement of the film other than a cut (gouge) is considered a scratch. Record each end point (if applicable) for gouge and scratch hardness (see 8.1).

NOTE 3—With some films, the two end points will be identical.

7.5 Make a minimum of two determinations for gouge hardness (7.3) and scratch hardness (7.4) for each pencil or lead.

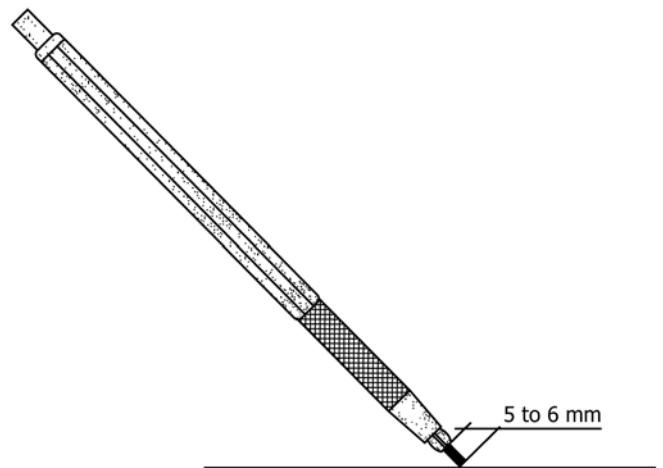

FIG. 2 View of Mechanical Holder with Sharpened Drawing Lead

8. Report

8.1 Report the following information:

8.1.1 The two end points as follows:

8.1.1.1 *Gouge Hardness*—The hardest pencil that will leave the film uncut for a stroke length of at least 3 mm ($\frac{1}{8}$ in.).

8.1.1.2 *Scratch Hardness*—The hardest pencil that will not rupture or scratch the film.

8.1.2 The make and grade of lead or pencil used, and

8.1.3 Any deviation from standard conditions, including roughness in the finish.

9. Precision and Bias

9.1 *Precision*—In an interlaboratory test of this test method with three different films on panels, ten laboratories and operators, and repeated by switching leads and panels between laboratories, the within-laboratory standard deviation was found to be 0.52 and the between-laboratory standard deviation was found to be 0.61. Based on these standard deviations, the following criteria should be used for judging the acceptability of results at a 95 % confidence level:

9.1.1 *Repeatability*—Two results obtained by two operators within a laboratory using the same pencils and panels should be considered suspect if they differ by more than one pencil unit on the scale described in 5.1.

9.1.2 *Reproducibility*—Two results, each the mean of at least two determinations, obtained by operators in different laboratories using the same pencils and panels or different pencils with the same panels should be considered suspect if they differ by more than one pencil unit on the scale described in 5.1.

9.1.3 *Bias*—Since there is no acceptable material suitable for determining the bias for the procedure in this test method for measuring pencil hardness, bias cannot be determined.

10. Keywords

10.1 hardness (scratch); pencil hardness

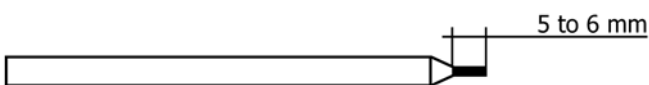

FIG. 1 View of Wood Pencil after Sharpening

SUMMARY OF CHANGES

Committee D01 has identified the location of selected changes to this standard since the last issue (D3363 – 00) that may impact the use of this standard.

(1) **Figs. 1 and 2** were added to make it clearer to the user of this standard how the trimmed wood from wood pencil and geometry of the lead tip should appear.

ASTM International takes no position respecting the validity of any patent rights asserted in connection with any item mentioned in this standard. Users of this standard are expressly advised that determination of the validity of any such patent rights, and the risk of infringement of such rights, are entirely their own responsibility.

This standard is subject to revision at any time by the responsible technical committee and must be reviewed every five years and if not revised, either reapproved or withdrawn. Your comments are invited either for revision of this standard or for additional standards and should be addressed to ASTM International Headquarters. Your comments will receive careful consideration at a meeting of the responsible technical committee, which you may attend. If you feel that your comments have not received a fair hearing you should make your views known to the ASTM Committee on Standards, at the address shown below.

This standard is copyrighted by ASTM International, 100 Barr Harbor Drive, PO Box C700, West Conshohocken, PA 19428-2959, United States. Individual reprints (single or multiple copies) of this standard may be obtained by contacting ASTM at the above address or at 610-832-9585 (phone), 610-832-9555 (fax), or service@astm.org (e-mail); or through the ASTM website (www.astm.org). Permission rights to photocopy the standard may also be secured from the Copyright Clearance Center, 222 Rosewood Drive, Danvers, MA 01923, Tel: (978) 646-2600; <http://www.copyright.com/>