



Designation: D3349 – 17

# Standard Test Method for Absorption Coefficient of Ethylene Polymer Material Pigmented with Carbon Black<sup>1</sup>

This standard is issued under the fixed designation D3349; the number immediately following the designation indicates the year of original adoption or, in the case of revision, the year of last revision. A number in parentheses indicates the year of last reappraisal. A superscript epsilon ( $\epsilon$ ) indicates an editorial change since the last revision or reappraisal.

## 1. Scope\*

1.1 This test method measures the amount of light transmitted through a film of carbon black pigmented ethylene polymer.

1.2 After calculation of the amount of light and film thickness, an absorption coefficient is calculated.

1.3 Whenever two sets of values are presented, in different units, the values in the first set are the standard, while those in parentheses are for information only.

1.4 *This standard does not purport to address all of the safety concerns, if any, associated with its use. It is the responsibility of the user of this standard to establish appropriate safety and health practices and determine the applicability of regulatory limitations prior to use.*

## 2. Referenced Documents

2.1 *ASTM Standards:*<sup>2</sup>

**E60 Practice for Analysis of Metals, Ores, and Related Materials by Spectrophotometry**

**D1248 Specification for Polyethylene Plastics Extrusion Materials for Wire and Cable**

## 3. Summary of Test Method

3.1 The transmission of light of a specified wavelength through thin ethylene polymer film is measured. The result is used to calculate an absorption coefficient that is a reciprocal function of transmission after correction for thickness.

## 4. Significance and Use

4.1 The absorption coefficient of polyolefin polymer pigmented with carbon black is useful to judge the degree and uniformity of dispersion of the pigment, and the adequacy of

<sup>1</sup> This test method is under the jurisdiction of ASTM Committee D09 on Electrical and Electronic Insulating Materials and is the direct responsibility of Subcommittee D09.07 on Electrical Insulating Materials.

Current edition approved March 1, 2017. Published March 2017. Originally approved in 1974. Last previous edition approved in 2012 as D3349 – 12. DOI: 10.1520/D3349-17.

<sup>2</sup> For referenced ASTM standards, visit the ASTM website, www.astm.org, or contact ASTM Customer Service at service@astm.org. For *Annual Book of ASTM Standards* volume information, refer to the standard's Document Summary page on the ASTM website.

the quantitative level of pigment addition. These factors are used to predict the performance of the polymer material in response to prolonged exposure to ultraviolet light as evidenced by minimal changes in specific properties.

NOTE 1—This test method was developed to evaluate ethylene polymer materials pigmented with small particle size carbon blacks suitable for UV protection. It is not known how accurate and reproducible the test would be with larger (35 nm or greater) particle size blacks.

## 5. Apparatus

5.1 *Spectrophotometer*—An instrument in accordance with Practice E60 is required.

NOTE 2—Consult the spectrophotometer's operation manual or consult the manufacturer of the instrument for the calibration procedure.

5.2 *Mold*—A mold in accordance with Figs. 1 and 2. Make the mold of Ketos steel (or equivalent) hardened to Rockwell C45, with mold surfaces chromium plated to 0.005-mm (0.0002-in.) minimum thickness.

5.3 *Specimen Holder*—Cut two concentric rings from phenolic-paper laminate or other suitable material to the dimensions shown in Fig. 3. Slip fit the rings snugly one within the other.

5.4 *Reference Material*—A reference material is required having an absorbance value of 1.0 to 1.2 at 375 nm as measured by the instrument used for testing.

5.4.1 *Neutral Density Filter*,<sup>3</sup> M-type carbon 0.85 density, laminated between cellulose acetate sheets has been found satisfactory. Since this material is furnished as a rigid sheet, it cannot be mounted as described in Section 7. Instead, a special mount must be prepared by cutting Ring 1 of Fig. 3 in half around its circumference to give two rings about 2 mm (0.08 in.) thick. Cut a 22-mm (0.87-in.) circle from the laminated filter, sandwich this between the two 2-mm rings, and slide the outer ring (Ring 2 of Fig. 3) over this composite.

5.4.2 An alternative reference material can be prepared by any user of this test method. Prepare an alternative reference

<sup>3</sup> The sole source of supply of the apparatus known to the committee at this time is The Kodak neutral density filter, No. 5, available from the Eastman Kodak Co.. If you are aware of alternative suppliers, please provide this information to ASTM International Headquarters. Your comments will receive careful consideration at a meeting of the responsible technical committee,<sup>1</sup> which you may attend.

\*A Summary of Changes section appears at the end of this standard

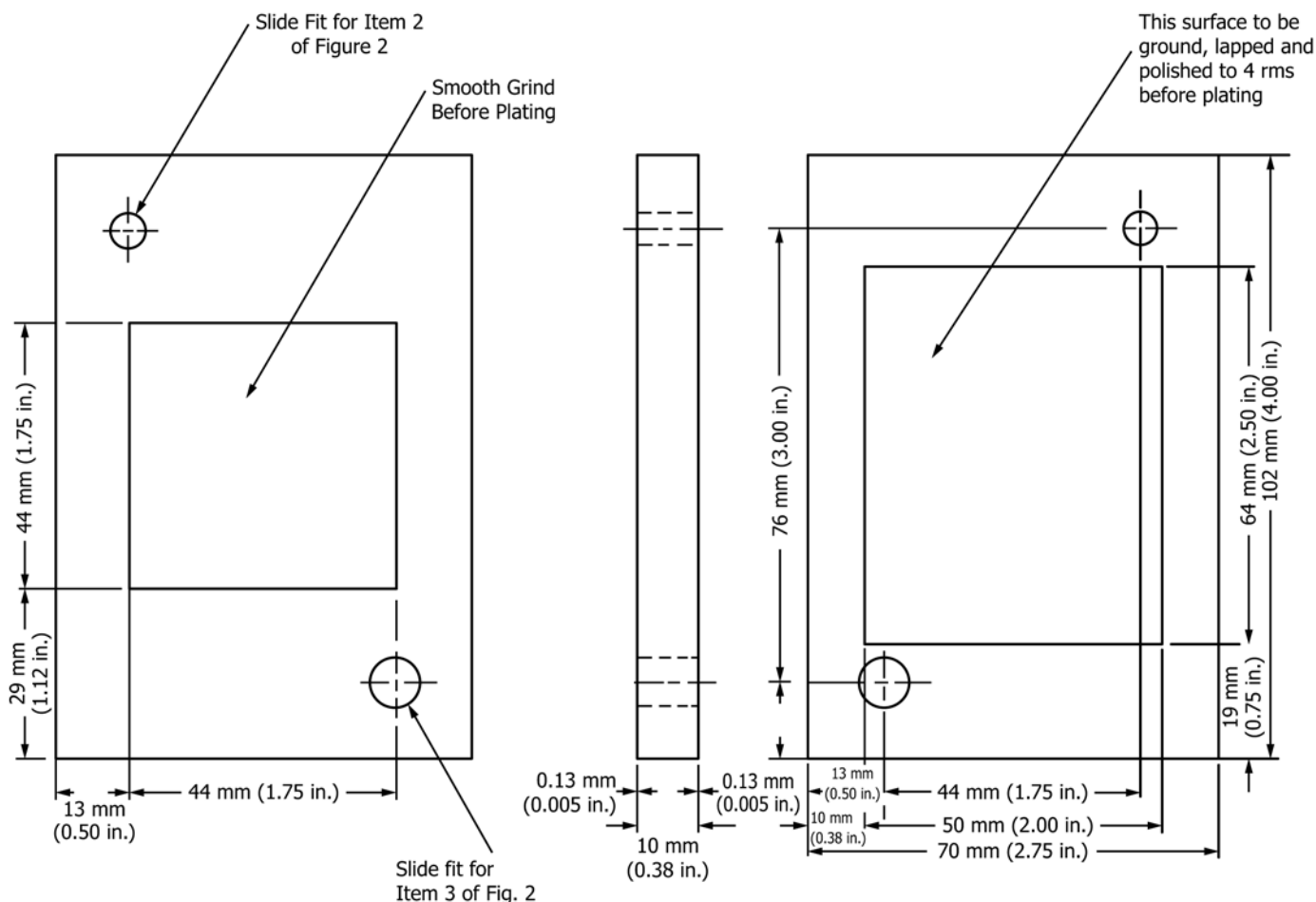

FIG. 1 Mold, Top Platen

material consisting of a highly uniform sample of ASTM Type I polyethylene (see Specification D1248) containing about 1 % of a 20-nm carbon black (either channel or furnace type). Press out a uniform film of this material and mount as in Section 8 to meet the above requirements. Reference materials so prepared shall show no more than  $\pm 4$  % variation from the average absorbance value when measured at any point at 375 nm in the instrument used for testing.

## 6. Calibration and Standardization

6.1 Allow the spectrophotometer to stabilize. Using the spectrophotometer manufacturer's instructions, set the zero and infinity values on the absorbance scale.

6.2 Insert the mounted reference material in the spectrophotometer and place it into the light beam. Read and record the absorbance value using the conditions that bring the value nearest to zero on the absorbance scale. With the reference material still in the beam, readjust the slit width to bring the reading back to zero. Recheck the infinity value.

## 7. Conditioning

7.1 No special conditioning is required.

## 8. Specimen Preparation

8.1 Prepare three test specimens from each lot of material by hot-pressing the ethylene polymer at a suitable temperature between highly polished plates, such as those shown in Figs. 1 and 2, using a charge sufficient to yield a specimen 40 to 50 mm in diameter and approximately 0.01 mm in thickness. Double pressing expedites the preparation of satisfactory specimens, that is, pressing to approximately 0.05 mm thickness and then pressing a section of that sheet to the required 0.01 mm thickness. Use of a silicone mold release agent is also recommended. For each specimen in turn, carefully transfer the specimen to the inner ring of the specimen holder (Ring 1, Fig. 3). With the specimen positioned concentrically over the inner ring, carefully press the outer ring (Ring 2, Fig. 3) down over it to complete the mounting operation. Mount the specimen firmly, taut, and wrinkle-free. Visually examine the mounted

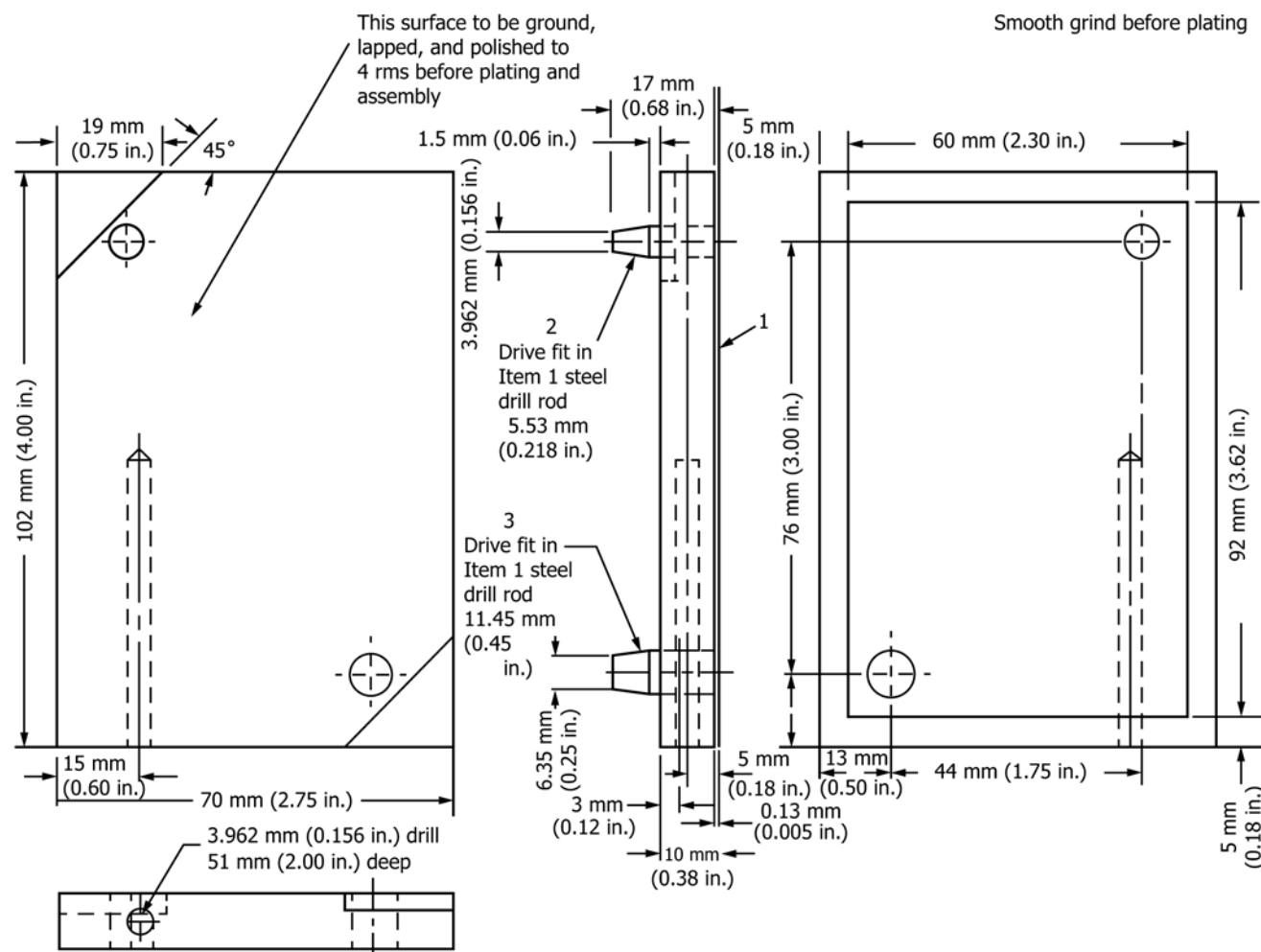

FIG. 2 Mold, Bottom Platen

test specimen against a suitable light source. It must be uniform in color and free of clear spots or holes. Mark and identify three points approximately 120° apart on the outer ring of each specimen.

**9. Procedure**

9.1 Bring the first mounted specimen into measuring position using the remaining outer position of the specimen holder, keeping the specimen as close to the receiver as possible. Position the specimen with one of the 120° marks at the top. Open the shutter, read and record the absorbance value  $v_1$ . The absorbance value recorded is equal to that indicated on the meter plus the measured value for the reference material.

9.2 Close the shutter and recheck the reference material. Rotate the specimen to bring the next 120° mark to the top and obtain the absorbance value  $v_2$ . Repeat the procedure with the third 120° mark at the top to obtain the value  $v_3$ . Average the values  $v_1$ ,  $v_2$ , and  $v_3$  to obtain the average absorbance  $\bar{v}$ . If any value of  $v$  differs from  $\bar{v}$  by more than 10 %, discard the specimen and replace it.

9.3 Remove the film from the specimen mounting rings by cutting it carefully along the boundary between the two rings and weigh it to the nearest 0.0001 g. The No. 11 Bard-Parker

scalpel blade<sup>4</sup> in a suitable handle has been found very effective for the cutting operation. Measure the diameter and calculate the area of the specimen. Calculate average specimen thickness as follows:

$$t = (10^{-2} \cdot W)/(D \cdot A) \tag{1}$$

where:

- $t$  = thickness, m,
- $W$  = weight, g,
- $D$  = density, g/cm<sup>3</sup>, and
- $A$  = area, cm<sup>2</sup>.

NOTE 3—The nominal density value for black low density ethylene polymer is 0.923 g/cm<sup>3</sup>.

9.4 Repeat 9.1 – 9.3 for the second and third specimens.

**10. Calculation**

10.1 Calculate the absorption coefficient of each specimen, in turn, as follows:

<sup>4</sup> The sole source of supply of the apparatus known to the committee at this time is the No. 11 Bard-Parker scalpel blade, available from most laboratory supply houses. If you are aware of alternative suppliers, please provide this information to ASTM International Headquarters. Your comments will receive careful consideration at a meeting of the responsible technical committee,<sup>1</sup> which you may attend.

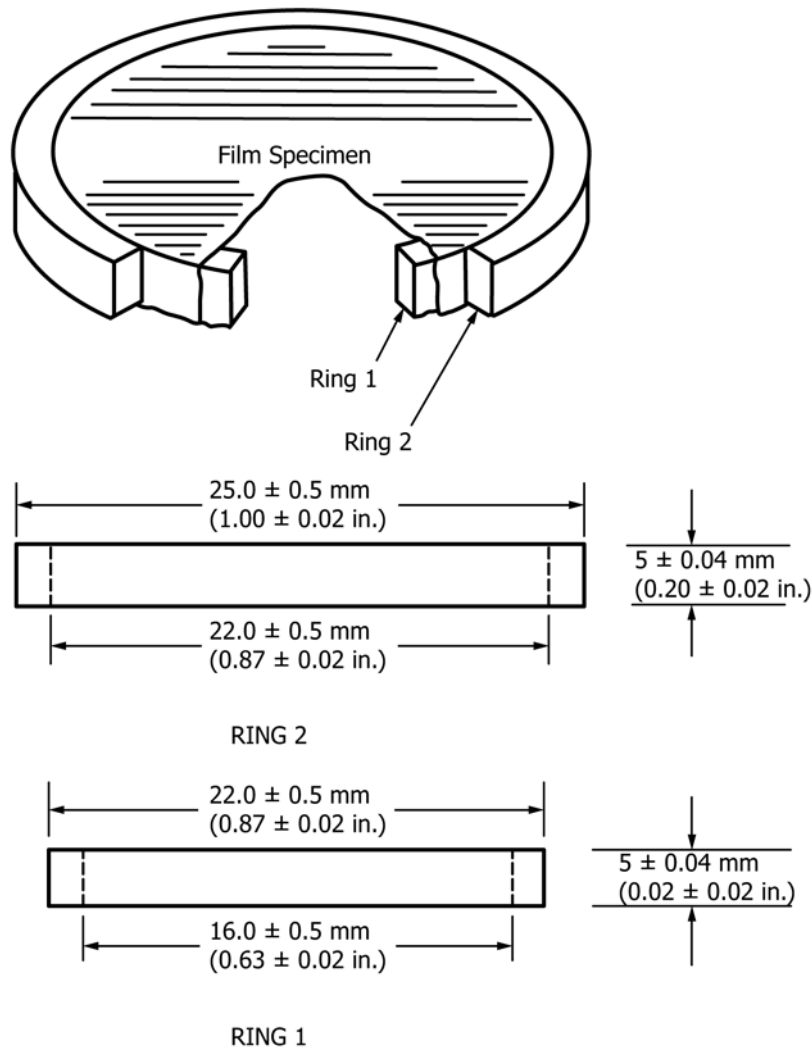

RING 1

NOTE 1—If required, adjust either the inside diameter of Ring 2 or outside diameter of Ring 1 to obtain a snug fit of pressed film.

FIG. 3 Specimen Mounting Rings

$$a = (10^{-3} \cdot 2.303 \cdot \bar{v}) / (t) \quad (2)$$

where:

$a$  = absorption coefficient, 1000 (absorbance/metre), at 375 nm,

$\bar{v}$  = average absorbance as found in 9.2, and

$t$  = thickness,  $m$ , as found in 9.3.

10.2 Average the three values,  $a$ , for the three specimens to obtain the value for the sample.

## 11. Report

11.1 Report the following:

11.1.1 Complete identification of the material tested,

11.1.2 Nominal density of the material tested,

11.1.3 Calculated absorption coefficient of each specimen tested,

11.1.4 Average absorption coefficient of three specimens tested, which is the value for the sample, and

11.1.5 Type and model of spectrophotometer used.

11.1.6 Date of test

11.1.7 Name of operator

## 12. Precision and Bias

12.1 Precision:

12.1.1 In the early 1970's, a round-robin study was conducted by five laboratories using one sample of carbon black-pigmented ethylene polymer and the same make and model of spectrophotometer. Each laboratory molded from two to five test specimens from the sample and determined the absorption coefficient of each. The following statistics, each expressed in the units of 1000 (absorbance/metre), were derived from the data submitted for this one sample.

Mean = 443  
 $S_r$  = 24  
 $S_R$  = 43

12.1.2 Interpretation of the data for the intervals  $S_r$  and  $S_R$  given above are as follows.

12.1.2.1 *Repeatability*—In comparing two averages (of three specimens each) for the sample obtained in one laboratory by one operator on the same day, the averages are judged as not equivalent if they differ by more than  $S_r$ .

12.1.2.2 *Reproducibility*—In comparing two averages (of three specimens each) for the sample obtained in different laboratories by different operators on different days, the averages are judged as not equivalent if they differ by more than  $S_R$ .

12.1.2.3 The judgments in 12.1.2.1 and 12.1.2.2 will be correct in approximately 95 % of such comparisons.

#### 12.2 *Bias*:

12.2.1 In the round-robin study, it was found that different makes and models of spectrophotometer can produce system-

atically different results for the average absorbance of a specimen, with the maximum consistent difference being 6 % relative for the four types of instrument used in the study.

12.2.2 In critical applications, such as conformance of a material to a specification, it is necessary for the buyer and seller to agree upon the instrument that is to be used or to establish a correlation between the two types of instruments in use.

### 13. Keywords

13.1 absorption coefficient; carbon black; ethylene polymer

## SUMMARY OF CHANGES

Committee D09 has identified the location of selected changes to this standard since the last issue (D3349 – 12) that may impact the use of this standard. (Approved March 1, 2017.)

(1) The density of low density polyethylene was corrected to 0.923 g/cm, based upon Test Method D1238.

(2) Spelling of spectrophotometer was corrected in 6.1 and 6.2.

*ASTM International takes no position respecting the validity of any patent rights asserted in connection with any item mentioned in this standard. Users of this standard are expressly advised that determination of the validity of any such patent rights, and the risk of infringement of such rights, are entirely their own responsibility.*

*This standard is subject to revision at any time by the responsible technical committee and must be reviewed every five years and if not revised, either reapproved or withdrawn. Your comments are invited either for revision of this standard or for additional standards and should be addressed to ASTM International Headquarters. Your comments will receive careful consideration at a meeting of the responsible technical committee, which you may attend. If you feel that your comments have not received a fair hearing you should make your views known to the ASTM Committee on Standards, at the address shown below.*

*This standard is copyrighted by ASTM International, 100 Barr Harbor Drive, PO Box C700, West Conshohocken, PA 19428-2959, United States. Individual reprints (single or multiple copies) of this standard may be obtained by contacting ASTM at the above address or at 610-832-9585 (phone), 610-832-9555 (fax), or service@astm.org (e-mail); or through the ASTM website (www.astm.org). Permission rights to photocopy the standard may also be secured from the Copyright Clearance Center, 222 Rosewood Drive, Danvers, MA 01923, Tel: (978) 646-2600; http://www.copyright.com/*