



Designation: D3342 – 90 (Reapproved 2017)

## Standard Test Method for Dispersion Stability of New (Unused) Rolling Oil Dispersions in Water<sup>1</sup>

This standard is issued under the fixed designation D3342; the number immediately following the designation indicates the year of original adoption or, in the case of revision, the year of last revision. A number in parentheses indicates the year of last reapproval. A superscript epsilon ( $\epsilon$ ) indicates an editorial change since the last revision or reapproval.

### 1. Scope

1.1 This test method covers determination of the dispersion stability of dispersions of rolling oils in water. It is applicable to oils whose water dispersions are stable under moderate agitation, but which show at least some separation upon standing quiescent for ½ h, by rising of the oil particles.

1.2 The values stated in SI units are to be regarded as standard. No other units of measurement are included in this standard.

1.3 *This standard does not purport to address all of the safety concerns, if any, associated with its use. It is the responsibility of the user of this standard to establish appropriate safety and health practices and determine the applicability of regulatory limitations prior to use.* For specific warning statements, see 6.2, A2.1, and A2.5.

1.4 *This international standard was developed in accordance with internationally recognized principles on standardization established in the Decision on Principles for the Development of International Standards, Guides and Recommendations issued by the World Trade Organization Technical Barriers to Trade (TBT) Committee.*

### 2. Referenced Documents

2.1 *ASTM Standards:*<sup>2</sup>

D1126 Test Method for Hardness in Water

D1293 Test Methods for pH of Water

### 3. Summary of Test Method

3.1 The rolling oil is dispersed in a standard test water, in a standard container, under standard conditions of time, agitation, and concentration. When the agitation is stopped, the

resulting decrease in oil concentration at a specified point near the bottom of the container is measured at certain time intervals and plotted.

### 4. Significance and Use

4.1 Each steel rolling mill and operation is particular as to the degree of stability of dispersion required to effect maximum efficiency of lubrication and cooling. This test method is designed to differentiate between coolants for this use. A similar situation is encountered with aluminum rolling mills, but significant differences in designated settling times be required outside the parameter of times used herein. Precision data have only been obtained relative to metastable dispersions for steel mill rolling oils.

### 5. Apparatus

5.1 *Mixing Beaker*,<sup>3,4</sup> 5800 mL capacity, made of stainless steel, modified as shown in Annex A2.

5.2 *Combination Agitator and Temperature Control Device*.<sup>4,5</sup>

5.3 *Babcock Centrifuge Bottles*<sup>4,6</sup>—The 165 mm cream test bottle, with 5 mL-neck permitting oil concentration readings from 0 % to 10 % is preferred. These bottles should be marked for filling to the 50 mL level which will normally be found close to the junction of body and neck. Sulfonation bottles may also be used.

5.4 *Centrifuge*, capable of whirling the Babcock bottles at sufficient speed to give a clean separation of oil and water under the test conditions. A centrifuge giving a relative centrifugal force (rcf) of 5009 at the bottle tips has been found to give good separations in 10 min.

<sup>1</sup> This test method is under the jurisdiction of ASTM Committee D02 on Petroleum Products, Liquid Fuels, and Lubricants and is the direct responsibility of Subcommittee D02.L0.04 on Metal Deformation Fluids and Lubricants.

Current edition approved June 1, 2017. Published July 2017. Originally approved in 1990. Last previous edition approved in 2012 as D3342 – 90 (2012). DOI:10.1520/D3342-90R17.

<sup>2</sup> For referenced ASTM standards, visit the ASTM website, www.astm.org, or contact ASTM Customer Service at service@astm.org. For *Annual Book of ASTM Standards* volume information, refer to the standard's Document Summary page on the ASTM website.

<sup>3</sup> The sole source of supply of the apparatus (beaker #2-584F) known to the committee at this time is Fisher Scientific.

<sup>4</sup> If you are aware of alternative suppliers, please provide this information to ASTM International Headquarters. Your comments will receive careful consideration at a meeting of the responsible technical committee,<sup>1</sup> which you may attend.

<sup>5</sup> The sole source of supply of the apparatus (the Porta-temp) known to the committee at this time is Precision Scientific Co.

<sup>6</sup> The sole source of supply of the apparatus (cream test bottle No. 12-705 or sulfonation bottle No. 6-904) known to the committee at this time is Fisher Scientific.

5.5 To calculate the rpm required to achieve the stated rcf, use the following formula:

$$\text{rpm} = 1335\sqrt{\text{rcf}/d} \quad (1)$$

where:

- rcf = relative centrifugal force,
- d = diameter of swing measured between tips of opposite tubes when in rotating position, mm, and
- rpm = revolutions per minute.

5.6 *Stop Watch*, or similar timing device.

## 6. Reagents

6.1 *Buffered Synthetic Hard Water*, prepared in accordance with [Annex A2](#).

6.2 *Sulfuric Acid*, 30 % by volume in water. Lower acid concentrations may be used if clean separations are obtained. (**Warning**—Sulfuric acid is poison, corrosive, and a strong oxidizer.)

## 7. Procedure

7.1 The flow rate of the combination agitator and temperature control device should be between 3500 mL/min and 4500 mL/min. The flow rate should be measured with a piece of 6.35 mm inside diameter bore plastic tubing temporarily attached to the pump outlet and removed after this measurement. During the test, do not use attachments such as tubing, stopcocks, pinch clamps, etc. on the pump outlet.

7.2 Add 4275 mL of test water to the beaker, install the agitator-temperature control device, and adjust it for 60 °C temperature. When the water reaches this temperature, add 225 mL of the rolling oil to be tested. (The oil sample should be sufficiently agitated to assure complete mixing of oil components. With most materials, sufficient heat to melt all of the components will also be required, however, at no time should the temperature exceed 60 °C.) Continue controlled temperature agitation for 30 min.

7.3 While agitation continues, fill one Babcock bottle for an emulsion concentration control test, as follows: Open the pinch clamp on the beaker sample tap for 2 s to 3 s. Discard about 20 mL of emulsion to flush the tap, and attempt to come as cleanly as possible to the end. Close the pinch clamp, place the hose tip in a Babcock bottle, and fill it at a rapid flow rate to the 50 mL mark.

7.4 Stop agitation and restart the stop watch at zero time. Fill Babcock bottles as described above at 30 s and 1 min, 2 min, 4 min, 8 min, 16 min, and 32 min elapsed time. It is permissible to stop sampling sooner or later (such as at 16 min or 64 min) if such data are desired, but earlier sample times may not be omitted even for very stable emulsions, because the sampling process slightly affects further settling rates. For each sample, purge the sample tap several seconds ahead of time so that filling the Babcock bottle starts at the correct time.

7.5 Fill each Babcock bottle to the upper graduation line with 30 % by volume sulfuric acid. Swirl while filling. Spin in

the centrifuge for 10 min, or until a clean separation is obtained. It may be necessary to use a different mineral acid or to heat the filled Babcock bottles to facilitate a clean separation. (If however, none of these methods results in a clean separation, the test method cannot be considered applicable for that particular oil.) Read the difference in levels in terms of the Babcock bottle calibration scale at the top and bottom of the oil layer.

## 8. Calculation

8.1 For the sample bottle taken as a control during agitation, calculate the percent of oil found. Since the calibrations on the neck of the Babcock bottle usually range from 0 to 50, and correspond to 10 % oil in this test method, the difference in scale reading between the top and bottom of the oil layer divided by 5 equals the percent oil. If this result is not close to 5 %, the results are suspect until repeat runs verify the reproducibility of the discrepancy. Significant amounts of water soluble compounds in the oil sample might explain low concentrations, for example. If, by the end of the 30 min agitation period, any significant amount of free oil or inverted emulsion remains floating on the surface without being repeatedly drawn down into the water layer, the oil is probably too difficult to disperse for the test method to be applicable.

8.2 For each sample taken after agitation was stopped, calculate the amount of oil found as a percent of the amount found in the sample.

8.3 A single number used to describe the rolling oil emulsion stability is the slope of a straight line, fit by the method of least squares, to the base ten logarithms of both time, in minutes, and the measured concentrations in percent. In practice, to avoid taking the of zero, use the concentration plus 1 %.

8.4 The estimate of the Slope *b*, for an experimental trial is easily obtained by completing the following worksheet.

Time	Log <sub>10</sub> Time		Log <sub>10</sub> Concentration + 1 %	
	Actual	Coded (X)	(Y)	XY
0.5	-0.30103	-0.90309		
1.0	0.0	-0.60206		
2.0	0.30103	-0.30103		
4.0	0.60206	0.0		
8.0	0.90309	0.30103		
16.0	1.20412	0.60206		
32.0	1.50515	0.90309		

8.5 Enter the log of the test result plus 1 on the appropriate line. Form the product of each coded time (*X*) and the corresponding concentration (*Y*). Add the seven resulting values. The slope is then calculated by the following formula:

$$b = \sum XY / 2.53733 \quad (2)$$

## 9. Report

9.1 The test result should be reported by the form in [Fig. 1](#), or equivalent. Calculations of Slope *b* (see [8.4](#)) are to be used to test the precision of test method and define the stability of the dispersion by a single number.

Sample Designation _____	
Water Hardness (EDTA Method) _____	(Test Method D 1126 Method B)
Water pH _____	(Test Method D 1293)
Original Concentration Control Check (from 7.2 method) _____	%

Elapsed Time of Settling, min.	Relative Concentration, %
0.5	
1.0	
2.0	
4.0	
8.0	
16.0	
32.0	

**FIG. 1 Tentative Dispersion Stability Test Report Form**

**10. Precision and Bias**

10.1 *Precision*<sup>7</sup>—The precision of the test method as obtained by statistical examination of interlaboratory test results is as follows:

10.1.1 *Repeatability*—The difference between successive test results, obtained by the same operator with the same apparatus under constant operating conditions on identical test material, would in the long run, in the normal and correct operation of the test method, exceed the following value only in one case in twenty:

0.0736 slope

10.1.2 *Reproducibility*—The difference between two single and independent results, obtained by different operators working in different laboratories on identical test material, would in the long run, in the normal and correct operation of the test method, exceed the following value in only one case in twenty:

0.3028 slope

NOTE 1—The precision statement is based on the results from seven laboratories on six samples (see Table 1).

10.2 *Bias*—Since there is no accepted reference material suitable for bias determination of this test method, no statement on bias is being made.

**11. Keywords**

11.1 coolant; dispersion stability; emulsion; rolling oil

<sup>7</sup> Supporting data have been filed at ASTM International Headquarters and may be obtained by requesting Research Report RR:D02-1108.

**ANNEXES**

**(Mandatory Information)**

**A1. PREPARATION OF MIXING BEAKER**

A1.1 The mixing beaker<sup>3,4</sup> is a modification of a 5800 mL stainless beaker approximately 185 mm in diameter by 220 mm high (see Fig. A1.1).

A1.2 A piece of 6.35 mm outside diameter by 0.89 mm wall stainless tube is cut to 50 mm length, and the ends freed of burrs or other irregularities. It is then brazed horizontally

**TABLE 1 Slope b**

Laboratory	Test	H	I	G	K	L	J
A	1	0.0	-0.0031	-0.9192	-0.7188	-0.4935	-0.4822
	2	-0.0031	0.0	-0.8757	-0.6991	-0.4986	-0.4443
B	1	0.0	0.0	-0.5750	-0.5264	-0.7584	-0.7938
	2	0.0	0.0	-0.5660	-0.5410	-0.6426	-0.9548
C	1	-0.0274	0.0025	-0.6133	-0.8275	-0.5725	-0.6068
	2	0.0046	-0.0099	-0.6759	-0.8007	-0.5949	-0.4718
D	1	-0.0124	-0.0513	-0.8456	-0.7530	-0.4856	-0.3427
	2	-0.0500	0.0	-0.8077	-0.7399	-0.4047	-0.5714
E	1	-0.0169	-0.0128	-0.3988	-0.5793	-0.6145	-0.6970
	2	-0.0237	-0.0169	-0.3832	-0.6152	-0.5540	-0.6970
F	1	-0.0158	-0.0154	-0.6050	-0.5580	-0.6640	-0.9734
	2	-0.0338	-0.0097	-0.6377	-0.5653	-0.9630	-0.6779
G	1	-0.0428	-0.0032	-0.6393	-0.5600	-0.5111	-0.4668
	2	-0.0301	0.0041	-0.6531	-0.5856	-0.5458	-0.5017

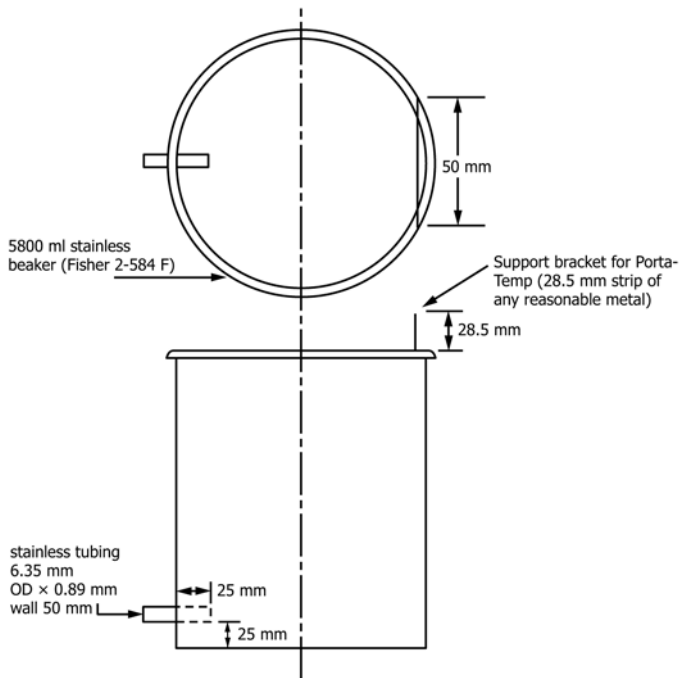

FIG. A1.1 Mixing Beaker for Dispersion Stability Test

through the wall of the beaker, such that its center line is 25 mm above the inside floor of the beaker, and it projects 25 mm inside the wall (see Fig. A1.1).

A1.3 A rectangle of sheet metal, 28.5 mm high by about 76 mm wide, is brazed to the top of the beaker, on the side opposite the sample tap, to permit attaching the control device, at a standard location (see Fig. A1.1).

A1.4 A 76 mm piece of thin-walled rubber tube of suitable inside diameter to grip the 6.35 mm stainless tube, is slipped onto the outer end of that tube. It is fitted with a push-to-open spring-operated pinchcock, serving as a sampling valve.

## A2. PREPARATION OF SYNTHETIC HARD WATER

A2.1 Prepare  $\text{CaCl}_2$  solution of 50 000 ppm hardness. From a freshly opened or carefully protected bottle of anhydrous  $\text{CaCl}_2$ , weigh out 55.5 g, and dissolve only in distilled water in a 1 L volumetric flask. (**Warning**—May cause skin irritation.)

A2.2 Prepare  $\text{MgSO}_4$  solution of 50 000 ppm hardness, using 123.2 g of  $\text{MgSO}_4 \cdot 7\text{H}_2\text{O}$  per litre.

A2.3 Prepare  $\text{NaHCO}_3$  solution at 50 000 ppm concentration, using 50 g of anhydrous  $\text{NaHCO}_3$  per litre.

A2.4 For each litre of test water required, add to 994 mL of distilled water 3 mL of the  $\text{CaCl}_2$  solution, 2 mL of the  $\text{MgSO}_4$  solution, and 1 mL of the  $\text{NaHCO}_3$  solution. Use Test Method D1126 to verify hardness, if desired.

A2.5 Adjust the pH of the hard water to 7.0 using dilute hydrochloric acid. (**Warning**—Poison. Corrosive. May be fatal if swallowed.) (See Test Methods D1293.)

*ASTM International takes no position respecting the validity of any patent rights asserted in connection with any item mentioned in this standard. Users of this standard are expressly advised that determination of the validity of any such patent rights, and the risk of infringement of such rights, are entirely their own responsibility.*

*This standard is subject to revision at any time by the responsible technical committee and must be reviewed every five years and if not revised, either reapproved or withdrawn. Your comments are invited either for revision of this standard or for additional standards and should be addressed to ASTM International Headquarters. Your comments will receive careful consideration at a meeting of the responsible technical committee, which you may attend. If you feel that your comments have not received a fair hearing you should make your views known to the ASTM Committee on Standards, at the address shown below.*

*This standard is copyrighted by ASTM International, 100 Barr Harbor Drive, PO Box C700, West Conshohocken, PA 19428-2959, United States. Individual reprints (single or multiple copies) of this standard may be obtained by contacting ASTM at the above address or at 610-832-9585 (phone), 610-832-9555 (fax), or service@astm.org (e-mail); or through the ASTM website (www.astm.org). Permission rights to photocopy the standard may also be secured from the Copyright Clearance Center, 222 Rosewood Drive, Danvers, MA 01923, Tel: (978) 646-2600; http://www.copyright.com/*