



Designation: D3336 – 17

Standard Test Method for Life of Lubricating Greases in Ball Bearings at Elevated Temperatures¹

This standard is issued under the fixed designation D3336; the number immediately following the designation indicates the year of original adoption or, in the case of revision, the year of last revision. A number in parentheses indicates the year of last reapproval. A superscript epsilon (ϵ) indicates an editorial change since the last revision or reapproval.

This standard has been approved for use by agencies of the U.S. Department of Defense.

1. Scope*

1.1 This test method covers the evaluation of the performance of lubricating greases in ball bearings operating under light loads at high speeds and elevated temperatures.

1.2 The values stated in SI units are to be regarded as standard.

1.2.1 *Exception*—The values given in parentheses are mathematical conversions to inch-pound units that are provided for information only and are not considered standard.

1.3 *This standard does not purport to address all of the safety concerns, if any, associated with its use. It is the responsibility of the user of this standard to establish appropriate safety and health practices and determine the applicability of regulatory limitations prior to use.* For specific warning statements, see 8.1.

1.4 *This international standard was developed in accordance with internationally recognized principles on standardization established in the Decision on Principles for the Development of International Standards, Guides and Recommendations issued by the World Trade Organization Technical Barriers to Trade (TBT) Committee.*

2. Referenced Documents

2.1 *ASTM Standards*:²

A600 Specification for Tool Steel High Speed

2.2 *ABMA Standard*:³

Standard 4, Tolerance Definitions and Gaging Practices for Ball and Roller Bearings

¹ This test method is under the jurisdiction of ASTM Committee D02 on Petroleum Products, Liquid Fuels, and Lubricants and is the direct responsibility of Subcommittee D02.G0.05 on Functional Tests - Temperature.

Current edition approved June 1, 2017. Published June 2017. Originally approved in 1975. Last previous edition approved in 2015 as D3336 – 05 (2015). DOI: 10.1520/D3336-17.

² For referenced ASTM standards, visit the ASTM website, www.astm.org, or contact ASTM Customer Service at service@astm.org. For *Annual Book of ASTM Standards* volume information, refer to the standard's Document Summary page on the ASTM website.

³ Available from American Bearing Manufacturers Assoc., 2025 M St., NW, Ste 800, Washington, DC 20036.

3. Summary of Test Method

3.1 A grease lubricated SAE No. 204 size ball bearing is rotated at 10 000 r/min under light load at a specified elevated temperature. Tests are continued until failure or completion of a specified number of hours of running time.

4. Significance and Use

4.1 This test method can be used to evaluate the ability of grease to provide adequate lubrication for extended periods of ball bearings operating under light loads at high speeds and elevated temperatures.

5. Apparatus^{4,5}

5.1 *Test Spindle*⁶(see Figs. 1-4), capable of operating at speeds of 10 000 r/min and temperatures as high as 371 °C (700 °F). The test bearing seat dimension shall be 19.99 mm to 20.00 mm (0.7870 in. to 0.7874 in.). For spindles having the test bearing and the support bearing in the same housing (CRC Type, Figs. 1-3) (Note 2) the internal construction of the spindle shall be such that the outboard support bearing, or both bearings are free to float axially in the housing. In designs where both bearings are free to float, the spindle shaft shall have a 0.508 mm to 0.762 mm (0.020 in. to 0.030 in.) free axial movement or end play. The outboard bearing seat dimension should be 19.99 mm to 20.00 mm (0.7870 in. to 0.7874 in.).

5.1.1 The test unit design (Fig. 1 and Fig. 2) should be such that a finger spring washer produces a 22 N to 67 N (5 lbf to 15 lbf) thrust load on the floating outboard support bearing.^{7,5}

5.2 *Bearing Housing*:

⁴ Complete apparatus is available from Falex Corp., 1020 Airpark Dr., Sugar Grove, IL 60554.

⁵ If you are aware of alternative suppliers, please provide this information to ASTM International Headquarters. Your comments will receive careful consideration at a meeting of the responsible technical committee,¹ which you may attend.

⁶ Pope Machinery Corporation Grease Test Spindles No. P-1911 or P-6301A-HT (Fig. 1) and No. P-7605-B (Fig. 2); and Falex Corp. spindles of the type shown in Fig. 1 and Fig. 2 have been found satisfactory for this purpose.

⁷ The sole source of supply of the apparatus known to the committee at this time is Falex Part No. 643-187-070, Falex Corp. 1020 Airpark Dr., Sugar Grove, IL 60554.

*A Summary of Changes section appears at the end of this standard

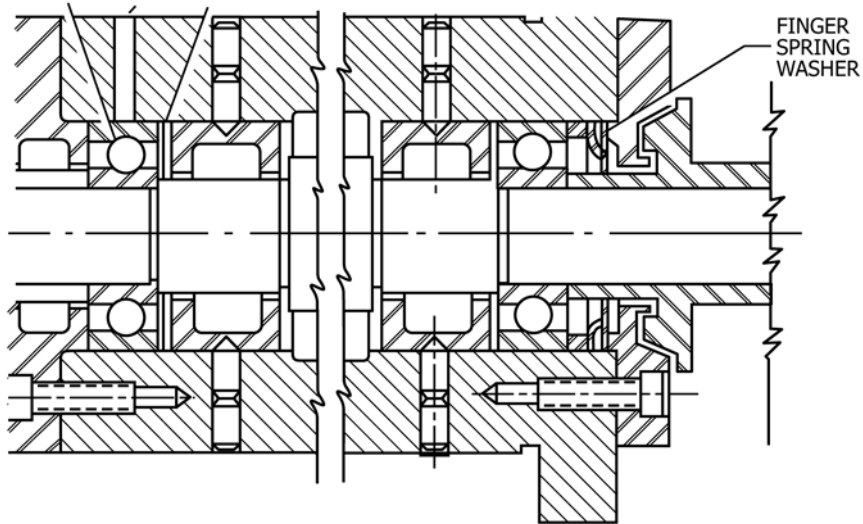

FIG. 1 Test Spindle (Both Bearings Floating)

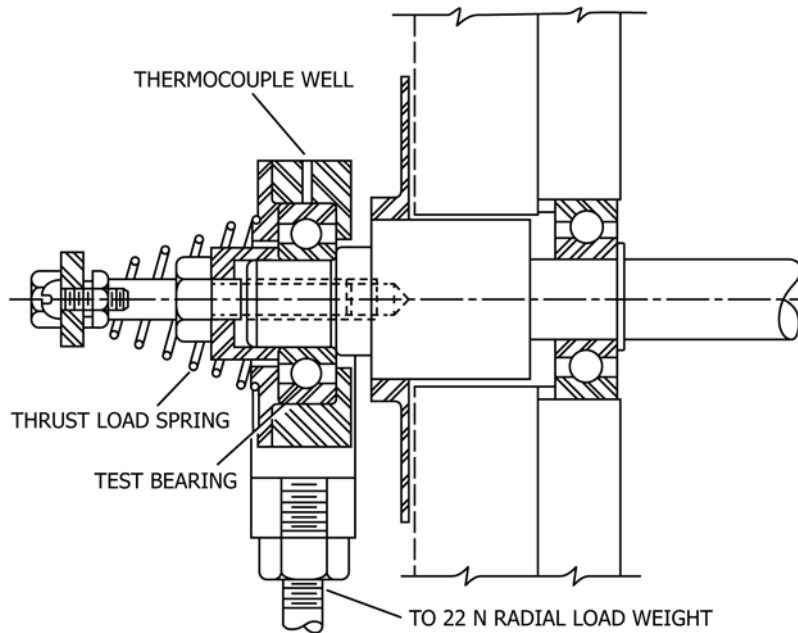

FIG. 2 Test Spindle (with Radial Load)

5.2.1 *For CRC Type Spindles*—The bearing housing diameter shall be 47.005 mm to 47.021 mm (1.8506 in. to 1.8512 in.) to give proper bearing mounting. Construction shall be such that the test bearing is equipped with flush spacers or shields to confine the grease to the bearing. The spacers or shields shall have a clearance between the inside diameter and the shaft of 0.127 mm to 0.178 mm (0.005 in. to 0.007 in.) per side.

NOTE 1—This type of spindle is described in CRC Research Technique for the Determination of Performance Characteristics of Lubricating Grease in Antifriction Bearings at Elevated Temperature (CRC Designations L-35-54 and CRC L-35-62).

5.2.2 *For Navy Type Spindles (Test Bearing Mounted Outside Spindle Housing)*—The bearing housing shall be constructed of material similar to that of the test bearing and shall be tempered to retain dimensional stability at temperatures up to 371 °C (700 °F). Internal diameter shall be 47.005 mm to 47.021 mm (1.8506 in. to 1.8512 in.). The housing cover shall be flush fitting to confine the grease to the bearing. Provision shall be made for insertion in the housing of one or two small thermocouples which shall lightly press on and be in continual contact with the outer race of the test bearing. The housing shall be fitted with lugs to accommodate a yoke and added

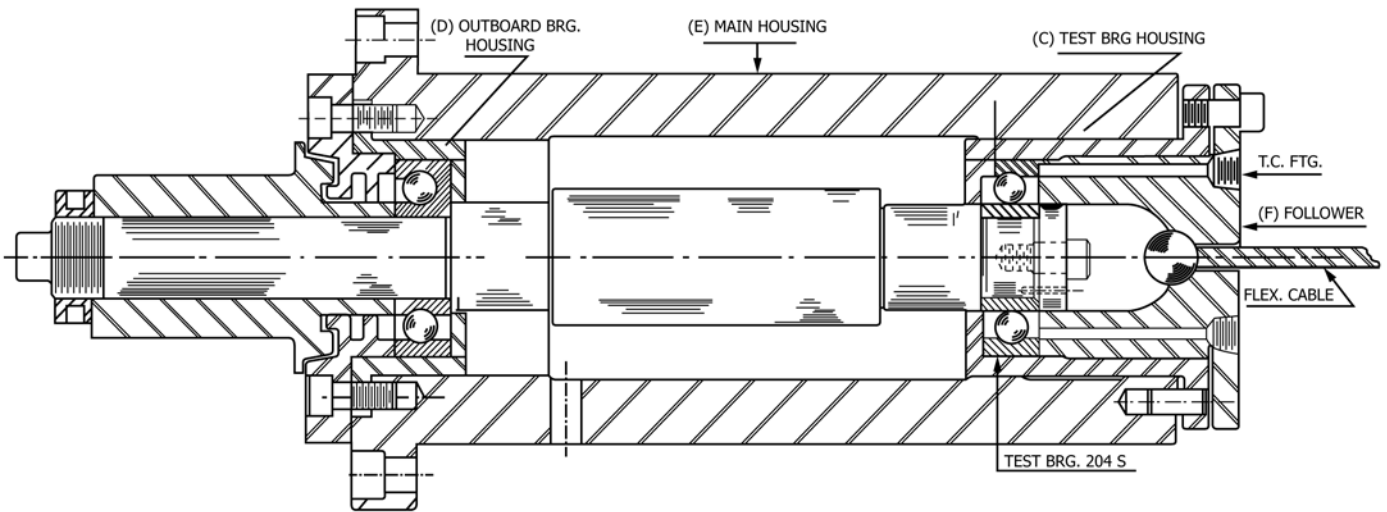

FIG. 3 Test Spindle Thrust Load Design

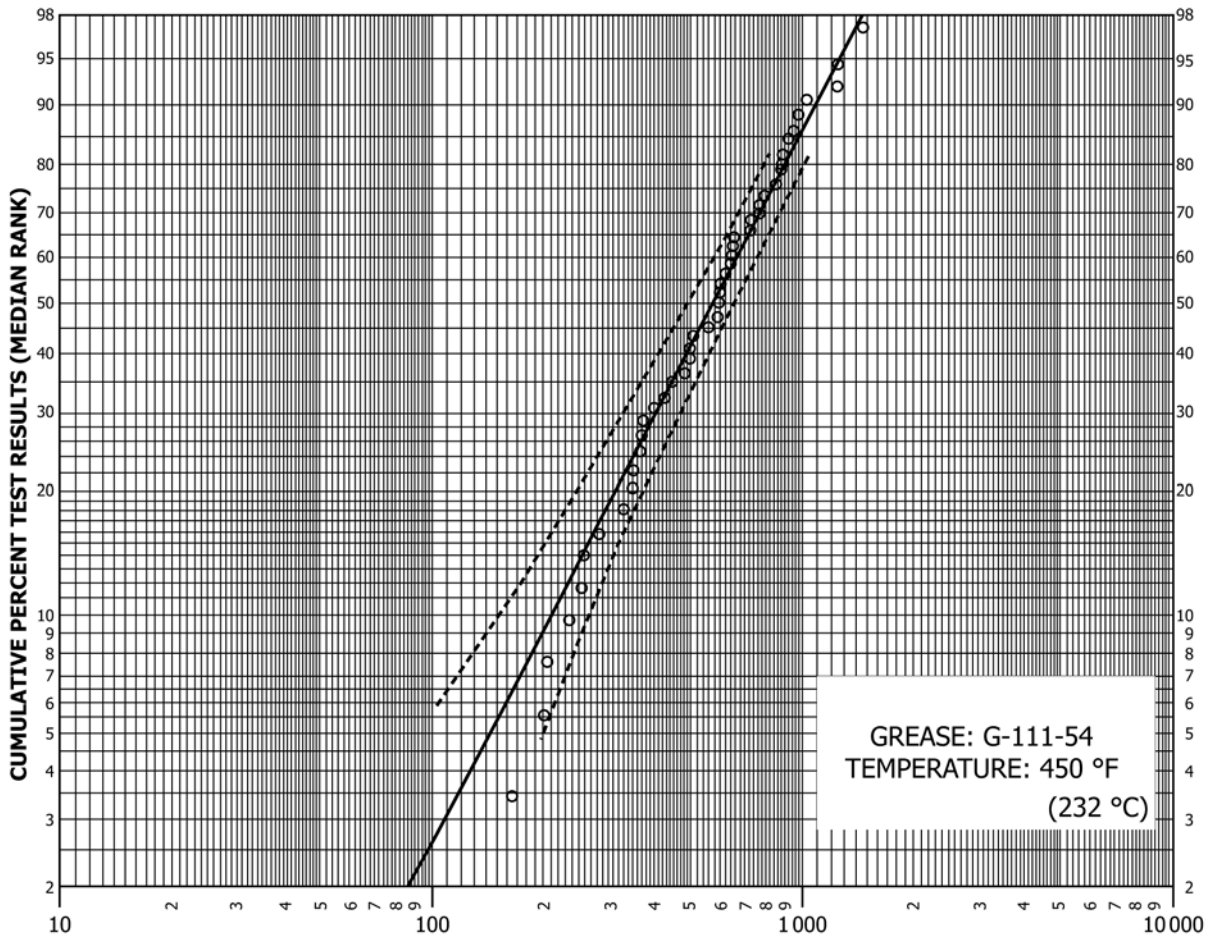

FIG. 4 G-111-54 Grease Life, Hours to Failure

weight so that a radial load may be applied to the test bearing. A thrust load of $22 \text{ N} \pm 2 \text{ N}$ ($5 \text{ lbf} \pm 0.55 \text{ lbf}$) shall be applied to the outer race of the bearing by means of a helical spring calibrated at room temperature.

5.3 *Motor Drive Assembly*—Spindle bracket and constant belt tension motor drive assembly capable of providing spindle

speeds up to $10\,000 \text{ r/min} \pm 200 \text{ r/min}$ by means of an endless belt. The motor shall be mounted so that a belt tension of approximately 67 N (15 lbf) can be maintained on the test spindle pulley.

5.4 *Oven*, removable, capable of producing a test temperature of $371 \text{ }^\circ\text{C}$ ($700 \text{ }^\circ\text{F}$) within $1\frac{1}{2} \text{ h}$.

5.5 Control Equipment:

5.5.1 The temperature at the outside diameter of the test bearing shall be maintained within 3 °C (5 °F) of the specified test temperature. The temperature control equipment shall be adequate to maintain the temperature at the outer race of the test bearing within the limits specified by control of the oven temperature. The oven temperature shall be controlled by means of a thermocouple placed in the oven cavity.

5.5.2 Suitable equipment such as adjustable reset relay and overload device for shutting off oven heaters and drive motor and other accessory equipment (timer, recorder, etc.) shall be provided. Oven temperature as well as bearing temperature should be recorded.

6. Materials

6.1 *Test Bearing*, SAE No. 204 size, fabricated from heat-resistant steel, suitable for temperatures as high as 371 °C (700 °F). The bearing shall be manufactured to ABEC-3 quality, having a radial clearance of from 0.025 mm to 0.031 mm (0.0010 in. to 0.0012 in.). See **Annex A1** which describes ABMA's standard method of measuring radial internal clearances of ball bearings. The bearing shall be equipped with a ball retainer fabricated from suitable material capable of withstanding temperatures as high as 371 °C (700 °F). Support bearings of CRC Type spindles shall be identical to the test bearings.

NOTE 2—Bearings fabricated from 18-4-1 high speed or M-50 (Specification **A600**) tool steel with retainers fabricated from heat-treated silver-plated beryllium copper⁸ have been found satisfactory for this purpose. Alternatively, for testing at temperatures of 149 °C (300 °F) and below, ASTM Test Bearings Size 6204 (PCN 12-433360-12) ABEC-3 has been found satisfactory. This bearing is fabricated from AISI 52100 steel, with a retainer fabricated from AISI C1010 steel and with an internal clearance range of 0.021 mm to 0.028 mm (0.0008 in. to 0.0011 in.).⁹

6.2 ASTM *n*-Heptane.¹⁰

6.3 *Mineral Spirits*, reagent grade.

7. Test Conditions

7.1 *Temperature*—As specified up to 371 °C (700 °F).

7.2 *Speed*—10 000 r/min ± 200 r/min.

7.3 *Test Cycle*:

7.3.1 Twenty-one and one-half hours running at temperatures of 149 °C (300 °F) and below—2½ h shutdown without applied heat.

7.3.2 Twenty hours running at temperatures of above 149 °C (300 °F)—4 h shutdown without applied heat.

8. Preparation of Apparatus

8.1 Just prior to lubrication for test, clean the test bearing by rotating it in warm (approximately 50 °C (120 °F)) mineral spirits, reagent grade (**Warning**—Flammable. Harmful if in-

haled) followed by two successive washes of ASTM *n*-heptane (**Warning**—Combustible. Vapor harmful) and flash dry in an oven at 71 °C (160 °F). Cool the bearing to room temperature.

8.2 Pack the bearing by hand so that it contains a weighed quantity of grease equivalent to 3.2 cm³ ± 0.1 cm³. The grease can also be measured by volume and applied to the bearing by means of a syringe. The grease shall be worked uniformly into both sides of the bearings, using a narrow blade spatula, making sure that the grease does not extend beyond the facet of the races. For CRC Type spindles the support bearing shall be packed full.

8.3 Assemble the test bearing, support bearing, and Z-spring (see **Fig. 1** and **Fig. 2**) on the spindle and fix the thermocouples into position so that it is in contact with the outer race of the test bearing (CRC Type spindles). For tests at 232 °C (450 °F) and above, replace the finger spring washer for each test. For Navy Type spindles insert the test bearing into the housing and press the bearing onto the spindle by application of a light force on the inner race. Place the cover plate in position, fix the thermocouples into position, and apply the radial and thrust loads.

9. Procedure

9.1 Rotate the bearing by hand for approximately 100 revolutions in each direction at a speed not exceeding 200 r/min. Start the drive motor and heater simultaneously and adjust the temperature controller to raise the bearing to test temperature within 1½ h. After 2 h of test operation at speed and control temperature, measure the temperature of the outer race of the test bearing. Adjust the controller such that the outer race of the test bearing is at test temperature for the grease. Record test hours (running time), control temperature, and outer-race temperature of the bearing at least every 24 h. Unless automatic controls are employed, a 72 h shutdown (without applied heat) over the weekend, shall be followed. For Navy Type spindles the oven door shall remain closed during periods of shutdown.

NOTE 3—Once satisfactory thermal stability has been established with the test bearing, no further manual adjustment is normally necessary. However, minor adjustments may be made to accommodate changing conditions of voltage, ambient temperatures, etc.

9.2 Continue the test until failure or completion of a specified number of known running times.

10. Results

10.1 The lubricant is considered to have failed when any one of the following conditions occurs:

10.1.1 Spindle input power increases to a value of 300 % above the steady state condition at test temperature.

10.1.2 An increase in temperature at the test bearing of 15 °C (27 °F) over the test temperature during any portion of a cycle. Ignore any temperature rise that takes place within 30 min after reaching test temperature after daily start-up.

10.1.3 There is loading of the test bearing or belt slippage at start up or during the test cycle.

⁸ The sole source of supply of the apparatus known to the committee at this time is Bearing MRC204S17, SKF Bearings, www.skf.com.

⁹ Supporting data have been filed at ASTM International Headquarters and may be obtained by requesting Research Report RR:D02-1272.

¹⁰ Described in 1996 *Annual Book of ASTM Standards*, Vol 05.04, Annex 2, Section A2.7 on Reference Materials.

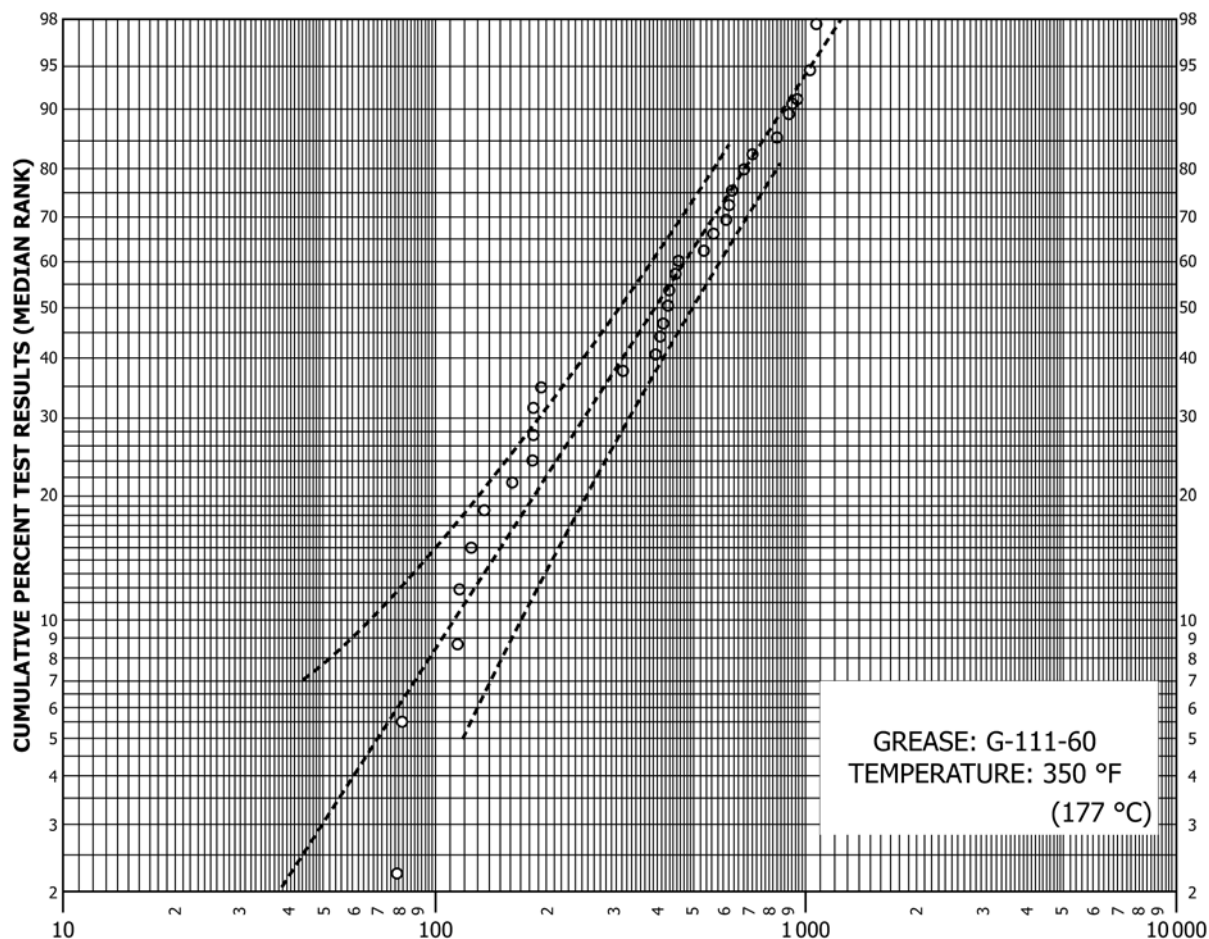

FIG. 5 G-III-60 Grease Life, Hours to Failure

11. Precision and Bias

11.1 The precision of this test is not known to have been obtained in accordance with currently accepted guidelines (for example, see Research Report RR:D02-1007).

11.2 Grease life data generated in two separate cooperative testing programs show appreciable scatter and follow Weibull distributions rather than normal distributions. Statistical parameters such as repeatability and reproducibility are therefore not appropriate. Weibull parameters such as slope, L_{10} , L_{50} and L_c better describe the distribution of test data.

11.2.1 Precision may be judged from Weibull plots of the test data, shown in Fig. 4 and Fig. 5, and from calculated Weibull parameters, summarized in Table 1 (90 % confidence limits are shown in parentheses). Precision may also be judged from the mean and range for the center 50 % of results reported, also summarized in Table 1.^{11,12}

¹¹ Further details may be found in *National Lubricating Grease Institute Spokesman*, Vol 39, No. 3, June 1975, pp. 81-95.

11.3 Replicate testing is essential when using this procedure since appreciable scatter in grease life results can be expected. A grease needs to be tested on a minimum of five different bearings to provide sufficient data for the Weibull statistical analysis to yield meaningful results.

11.4 *Bias*—The procedure for measuring life of lubricating greases in ball bearings at elevated temperatures has no bias because the value of performance life in ball bearings at elevated temperature can be defined only in terms of a test method.

12. Keywords

12.1 ball bearing; grease; life

¹² A variety of computer software programs are commercially available to enable calculation of Weibull statistics.

TABLE 1 Grease Life, Hours to Failure

Grease	GIII-54	GIII-60
Test temperature, °C (°F)	232 (450)	177 (350)
Number of cooperating laboratories	13	8
Number of test results	48	31
Weibull Parameters		
Slope	1.89 (1.56 to 2.27)	1.53 (1.19 to 1.92)
L_{10}	210 (151 to 269)	115 (67 to 171)
L_{50}	571 (487 to 657)	394 (310 to 494)
L_c	693 (601 to 792)	502 (405 to 616)
Mean	615	446
Range for center 50 % of results	336 to 776	183 to 608

ANNEX

(Mandatory Information)

A1. INTERNAL CLEARANCE MEASUREMENT

A1.1 Comments

A1.1.1 The following method describes how to measure the internal clearance of radial bearings based on ABMA’s Standard 4 (Section 3.6, Method 1).¹³

A1.1.2 This method is applicable to radial contact grooved ball bearings.

A1.1.3 This method is used for measuring the radial internal clearance directly employing simple means and without the use of a master bearing.

A1.1.4 The difference between minimum and maximum measured reading is the measured radial internal clearance. The average of the several sets of measurements is the radial internal clearance, C_R of the bearing.

A1.1.5 Prelubricated bearings and some designs of bearings with closures may adversely affect accuracy of gauging.

A1.2 Method

A1.2.1 Fasten the inner ring of the assembled bearing on a plate with shim inserted between inner ring and surface plate.

A1.2.2 Position the indicator against the outer ring outside surface and in line with the middle of the raceway. Hold the outer ring in contact with the rest of the direction A with care not to lift the opposite side. Move the outer ring repeatedly at this point up and down axially and oscillate circumferentially (for purpose of moving the balls to the bottom of the raceway) until the indicator can be seen to give a consistent maximum reading.

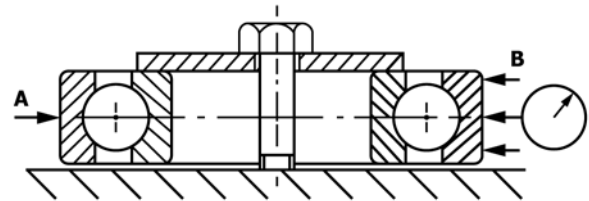

FIG. A1.1 Test Bearing Internal Clearance Measurement.

NOTE A1.1—If the indicator needle does not pass through a clear maximum or minimum reading, respectively, the shim is probably too thin.

A1.2.3 While continuing to hold the outer ring lightly in contact with the rest of the bearing in direction A, move the outer ring at this point first up and then down without circumferential motion. When the balls pass over the bottom of the raceways, the indicator will show a maximum reading which is recorded. See Fig. A1.1.

A1.2.4 Without changing the general location of the outer ring, hold it in contact with the bearing in direction B, with care not to lift the opposite side. Move the outer ring repeatedly at this point up and down axially and oscillate circumferentially (for purpose of moving the balls to the bottom of the raceway) until reading.

A1.2.5 Then, while continuing to hold the outer ring lightly in contact with the rest of the bearing in direction B, move the outer ring at this point first up and then down without circumferential motion. When the balls pass over the bottom of the raceway, the indicator will show a minimum reading, which is recorded.

A1.2.6 Compensate for possible out-of-roundness of the outer ring inner ring by repeating the same procedure several times at different angular positions.

¹³ This method was copyrighted in 1994 by the American Bearing Manufacturers Assoc., Inc. This method has been copied verbatim but has been formatted to ASTM style.

SUMMARY OF CHANGES

Subcommittee D02.G0 has identified the location of selected changes to this standard since the last issue (D3336 – 05 (2015)) that may impact the use of this standard. (Approved June 1, 2017.)

(1) Removed Adjunct ADJD3336, Standard Ball Bearings, from the test method.

ASTM International takes no position respecting the validity of any patent rights asserted in connection with any item mentioned in this standard. Users of this standard are expressly advised that determination of the validity of any such patent rights, and the risk of infringement of such rights, are entirely their own responsibility.

This standard is subject to revision at any time by the responsible technical committee and must be reviewed every five years and if not revised, either reapproved or withdrawn. Your comments are invited either for revision of this standard or for additional standards and should be addressed to ASTM International Headquarters. Your comments will receive careful consideration at a meeting of the responsible technical committee, which you may attend. If you feel that your comments have not received a fair hearing you should make your views known to the ASTM Committee on Standards, at the address shown below.

This standard is copyrighted by ASTM International, 100 Barr Harbor Drive, PO Box C700, West Conshohocken, PA 19428-2959, United States. Individual reprints (single or multiple copies) of this standard may be obtained by contacting ASTM at the above address or at 610-832-9585 (phone), 610-832-9555 (fax), or service@astm.org (e-mail); or through the ASTM website (www.astm.org). Permission rights to photocopy the standard may also be secured from the Copyright Clearance Center, 222 Rosewood Drive, Danvers, MA 01923, Tel: (978) 646-2600; <http://www.copyright.com/>