



Standard Test Method for Separation and Collection of Particulate and Gaseous Fluorides in the Atmosphere (Sodium Bicarbonate-Coated Glass Tube and Particulate Filter Method)¹

This standard is issued under the fixed designation D3268; the number immediately following the designation indicates the year of original adoption or, in the case of revision, the year of last revision. A number in parentheses indicates the year of last reapproval. A superscript epsilon (ϵ) indicates an editorial change since the last revision or reapproval.

This standard has been approved for use by agencies of the U.S. Department of Defense.

1. Scope

1.1 The sodium bicarbonate-coated glass tube and membrane filter method provides a means for the separation and collection of gaseous atmospheric forms of fluoride reactive with sodium bicarbonate and particulate forms of fluoride which are collected by a filter. The test method is applicable to 12-h sampling periods, collecting 1 to 500 μg of gaseous fluoride at a 15 L/min (0.5 ft^3/min) sampling rate or about 0.1 to 50 $\mu\text{g}/\text{m}^3$. The length of the sampling period can therefore be adjusted so that the amount of fluoride collected will fall within this range. The actual lower limit of the test method will depend upon the sensitivity of the analytical method employed and the quality of reagents used in tube preparation and analysis. It is recommended that the lower limit of detection should be considered as two times the standard deviation of the monthly arithmetic mean blank value. Any values greater than the blank by less than this amount should be reported as “blank value.”

1.2 The values stated in SI units are to be regarded as standard. The inch-pound units in parentheses may be approximate.

1.3 *This standard does not purport to address all of the safety concerns, if any, associated with its use. It is the responsibility of the user of this standard to establish appropriate safety and health practices and determine the applicability of regulatory limitations prior to use.*

2. Referenced Documents

2.1 ASTM Standards:²

D1193 Specification for Reagent Water

¹ This test method is under the jurisdiction of ASTM Committee D22 on Air Quality and is the direct responsibility of Subcommittee D22.03 on Ambient Atmospheres and Source Emissions.

Current edition approved Oct. 1, 2011. Published October 2011. Originally approved in 1973. Last previous edition approved in 2005 as D3268 – 91 (2005). DOI: 10.1520/D3268-91R11.

² For referenced ASTM standards, visit the ASTM website, www.astm.org, or contact ASTM Customer Service at service@astm.org. For *Annual Book of ASTM Standards* volume information, refer to the standard's Document Summary page on the ASTM website.

D1356 Terminology Relating to Sampling and Analysis of Atmospheres

D1357 Practice for Planning the Sampling of the Ambient Atmosphere

D3266 Test Method for Automated Separation and Collection of Particulate and Acidic Gaseous Fluoride in the Atmosphere (Double Paper Tape Sampler Method)

D3267 Test Method for Separation and Collection of Particulate and Water-Soluble Gaseous Fluorides in the Atmosphere (Filter and Impinger Method)

D3269 Test Methods for Analysis for Fluoride Content of the Atmosphere and Plant Tissues (Manual Procedures) (Withdrawn 2010)³

D3270 Test Methods for Analysis for Fluoride Content of the Atmosphere and Plant Tissues (Semiautomated Method)

3. Terminology

3.1 *Definitions*—For definitions of terms used in this test method refer to Terminology **D1356**.

4. Summary of Test Method

4.1 Gaseous fluorides are removed from the air stream by reaction with sodium bicarbonate coated on the inside wall of a borosilicate glass tube (**Note 1**). Particulate fluorides are collected on a filter following the tube. The fluoride collected by the tube is eluted with water or buffer and analyzed for fluoride. The particulate matter collected by the filter is eluted with acid and analyzed for fluoride (**1-4**).⁴ The results are reported as $\mu\text{g}/\text{m}^3$ of gaseous or particulate in air at 25°C (77°F) and 101.3 kPa (29.92 in. Hg).

NOTE 1—Some particulate matter will collect on the wall of the sample tube. If this loss is to be evaluated, use 7 test methods such as Test Method **D3266** or Test Method **D3267** for comparison since the filter for collecting particulate precedes the absorbers for gases Mandl and Weinstein (**2**)

³ The last approved version of this historical standard is referenced on www.astm.org.

⁴ The boldface numbers in parentheses refer to references at the end of this test method.

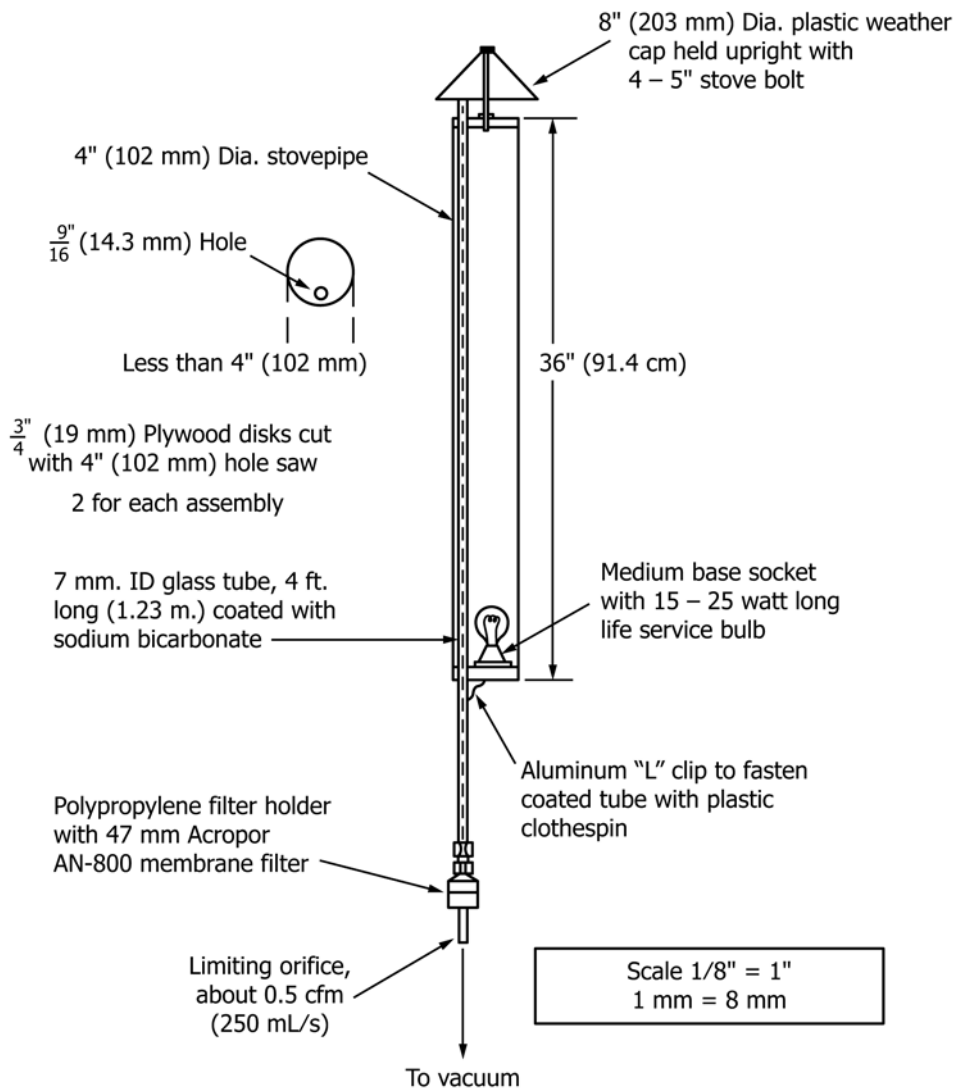

FIG. 1 Sodium Bicarbonate-Coated Glass Tube Illustrating Simple Heating Device

provide some information relative to potential loss of particulate matter.

5. Significance and Use

5.1 The sodium bicarbonate coated tube filter method provides a means of separating and collecting atmospheric gaseous fluoride and particulate fluoride samples.

5.2 Since the samples are collected on the dry tube and filter, the fluoride may be eluted with a small volume of eluant (see Section 10 for specific instructions on fluoride elution). Elution into a small volume and the sensitivity of the analytical methods employed allow the analysis of the collected fluoride to fractional parts of a microgram per cubic metre on samples taken for a 12-h period.

6. Interferences

6.1 Significant amounts of acid aerosols or gases might neutralize or acidify the bicarbonate coating and prevent quantitative uptake of gaseous fluoride from the atmosphere. If this potential interference needs to be evaluated, the alkalinity of the water extract may provide relevant information.

6.2 The presence of large amounts of aluminum or certain other metals or phosphates can interfere with subsequent analyses of the tubes or filters by calorimetric or electrometric methods. This is a problem inherent with any collection method for fluoride.

7. Apparatus

7.1 *Glass Tubing*—1200-mm (4-ft) lengths of 7-mm inside diameter borosilicate glass tubing, coated with sodium bicarbonate, in accordance with the requirements outlined in 7.6.

7.2 *Filter and Holder*—Connect the tubing directly to the filter holder and filter for the collection of particulate matter for particulate fluoride analysis (see Fig. 2).

NOTE 2—Use of material other than that recommended in footnote 6 or Fig. 2 will result in gaseous fluoride absorption on the material.

7.3 Air Sampling System:

7.3.1 The tube and filter are followed by an air sampling system which is capable of sampling at a rate of 15 L/min (0.5

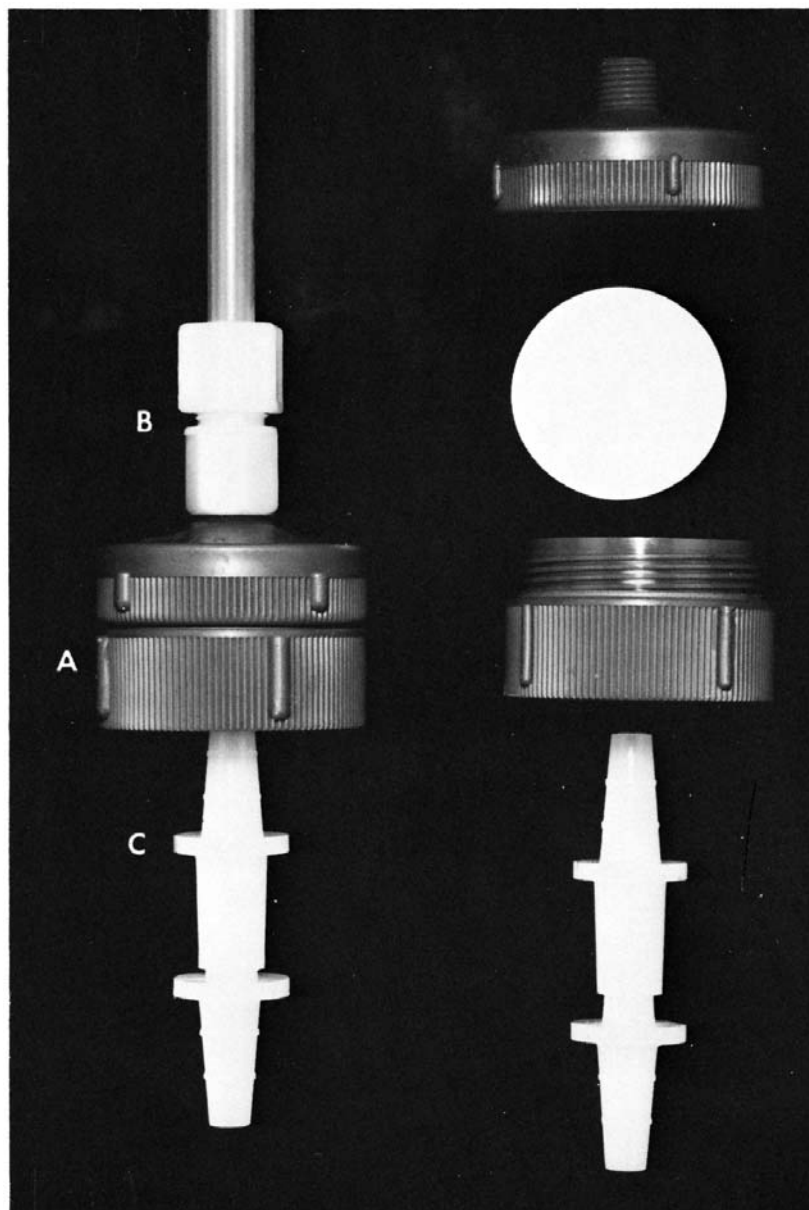

FIG. 2 Details of Attachment of the Filter Assembly and Limiting Orifice to a Bicarbonate-Coated Tube (7-mm Inside diameter). (A) Polypropylene Filter Holder, (B) Plastic Female Connector, (C) Limiting Orifice

ft³/min) and measuring the total air sampled on a time rate basis or with a totalizing meter. See Test Method D3267 for sampling equipment, and the configuration and calibration.

7.3.2 The system shall be equipped so that pressure and temperature of the gas at the point of metering also are known for correcting sample volumes to standard conditions of 101.3 kPa (29.92 in. Hg) at 25°C (77°F).

7.3.3 Assemble the sampling system so that the inlet of the tube is 4 to 6 m above ground level (see Practice D1357) and protected from rain in such a manner as not to interfere with the free passage of aerosol fluorides.

7.4 *Light Bulb or Cone Heater*, 30-W, installed to heat the gases to a temperature where condensation will not occur.

7.5 *Configuration of Sampling Equipment*—Fig. 1 is a sketch of the sampling system. Other systems that meet the requirements outlined, are also satisfactory.

7.6 *Criteria for Coating of the Borosilicate Tubes:*

7.6.1 The coating shall be visible uniform coating on the full length of the tube.

7.6.2 The coating shall not contain any large crystals or heavy local deposits which could flake off and be collected with the aerosol fluorides.

7.6.3 The total coating shall contain less than 1 µg of fluoride when analyzed without exposure, including all the reagents used in the procedure. This is the reagent blank for the procedure.

7.6.4 Prepared tubes shall be sealed until time of use. Serum tube caps that have been thoroughly rinsed with reagent water (8.2) are recommended for this purpose.

7.6.5 Tubes shall be carried through the field procedure without exposure and also the subsequent analytical procedures to provide a sampling and analytical blank value. Check any materials that may come into contact with the tubes for freedom from contamination with fluoride. These field blanks will provide the data for the monthly arithmetic mean blank value. See **Note 3**.

NOTE 3—Do not expose the tubes except during sampling.

8. Reagents

8.1 *Purity of Reagents*—Reagent grade chemicals shall be used in all tests. All reagents shall conform to the specifications of the Committee on Analytical Reagents of the American Chemical Society, where such specifications are available.⁵

8.2 *Purity of Water*—Water shall be reagent water conforming to Specification **D1193**. Additionally, the water used shall be demonstrated to contain less than 0.005 µg of fluoride/mL by testing with a specific ion electrode or by concentration and photometric analysis.

8.3 *Detergent Solution*, low in fluoride and phosphate for initial cleaning of the tubes.

8.4 *Potassium Hydroxide, Alcoholic Solution*(10%)—Prepare a solution of 10% of potassium hydroxide (KOH) in methanol by dissolving 100 g of KOH in methanol and diluting the volume to 1 L with methanol. Mix thoroughly.

8.5 *Sodium Bicarbonate Solution* (5%)—Prepare a solution of 5% NaHCO₃ by dissolving 50 g of sodium bicarbonate (NaHCO₃) in water and diluting the volume to 1 L with methanol. Mix thoroughly.

8.6 *Sodium Hydroxide Solution* (1.0 N)—Dissolve 40.0 g of sodium hydroxide (NaOH) pellets in 250 mL of reagent water in a 1000-mL volumetric flask. Swirl to mix, cool, and dilute to 1000 mL with reagent water. Mix thoroughly.

8.7 *Sodium Hydroxide Solution* (5 N)—Dissolve 200 g of NaOH in 250 mL of reagent water in a 1000-mL volumetric flask. Swirl to mix, cool, and dilute to 1000 mL with reagent water. Mix thoroughly.

8.8 *Sulfuric Acid* (1.0 N)—Add 28 mL of concentrated H₂SO₄ (sp gr 1.84) to 250 mL of reagent water in a 1000-mL volumetric flask. Swirl to mix, cool, and dilute to 1000 mL with reagent water. Mix thoroughly.

8.9 *Total Ionic Strength Adjustment Buffer (TISAB)*—Add 57 mL of glacial acetic acid, 58 g of sodium chloride (NaCl) and 4.0 g of CDTA [(1,2-cyclohexylenedinitrilo)tetraacetic

acid] to 500 mL of distilled water. Stir and add 5 N NaOH solution (8.7) slowly until pH is between 5.0 and 5.5. Cool and dilute to 1 L.

8.10 *TISAB* (1+1)—Dilute the full strength TISAB (8.9) with an equal amount of water.

8.11 *Wetting Agent*, for use in the sodium bicarbonate solution to promote even wetting of the tube.

9. Procedure

9.1 *Coating of Borosilicate Glass Tubes:*

9.1.1 Clean the tubes successively with detergent (8.3), alcoholic KOH solution (8.4), and distilled water.

9.1.2 While still wet from the cleaning, wet the internal surface of the tube with the 5% NaHCO₃ solution (8.5).

9.1.3 Allow the tube to drain for about 10 s and dry the coating rapidly by passing hot, dry fluoride-free air downward through the tube, while it is hanging in a vertical position.

9.1.4 Provide the hot fluoride-free air stream by blowing air through a 4 to 8-mesh soda-lime trap and then through 1200 mm (4 ft) of coiled copper tubing heated by a small gas burner or heating tape. To simplify the drying, the hot air stream can be run through a manifold terminating in several outlet ports. The flow rate through the system shall be in the order of about 3 L/min per tube, and the drying should be complete in about 1 min.

9.1.5 After the tubes are dry, seal the ends with rubber serum caps which have been thoroughly rinsed with reagent water and store in a clean area until used.

9.2 *Preparation of Filters:*

9.2.1 Assemble the filters and filter holders in the laboratory and sealed if not used immediately.

9.2.2 Assemble the tubes and filters into a sampling unit prior to taking the tubes and filter holders to the sampling site. Keep the ends sealed until installed at the sampling site.

9.3 *Air Sampling Procedure:*

9.3.1 Take samples for 12-h periods, covering both day and night conditions, to provide sufficient fluoride for accurate measurement.

9.3.2 Collect the sample at 15 L/min (0.5 ft³/min) using a calibrated limiting orifice or other suitable device to control the flow at this rate (see **Fig. 3**).

9.3.2.1 Record total sample volume with the totalizing gas meter (7.3.1).

9.3.2.2 Record pressure drop and temperature at the meter at the beginning and end of each sampling period.

9.3.3 Cap the tube and filter assemblies at the end of the sampling period, and return them to the laboratory for analysis.

9.4 Coated and exposed tubes and filter holders may be sealed and stored indefinitely in a clean, fluoride-free area, prior to analysis.

10. Preparation of Samples for Fluoride Analysis

10.1 Perform the analysis in a work area with an atmosphere free of contamination by fluorides.

10.1.1 Separate the tubes and the filter assemblies.

10.2 *Preparation of Tubes for Fluoride Analysis:*

⁵ *Reagent Chemicals, American Chemical Society Specifications*, American Chemical Society, Washington, DC. For suggestions on the testing of reagents not listed by the American Chemical Society, see *Analar Standards for Laboratory Chemicals*, BDH Ltd., Poole, Dorset, U.K., and the *United States Pharmacopeia and National Formulary*, U.S. Pharmacopeial Convention, Inc. (USPC), Rockville, MD.

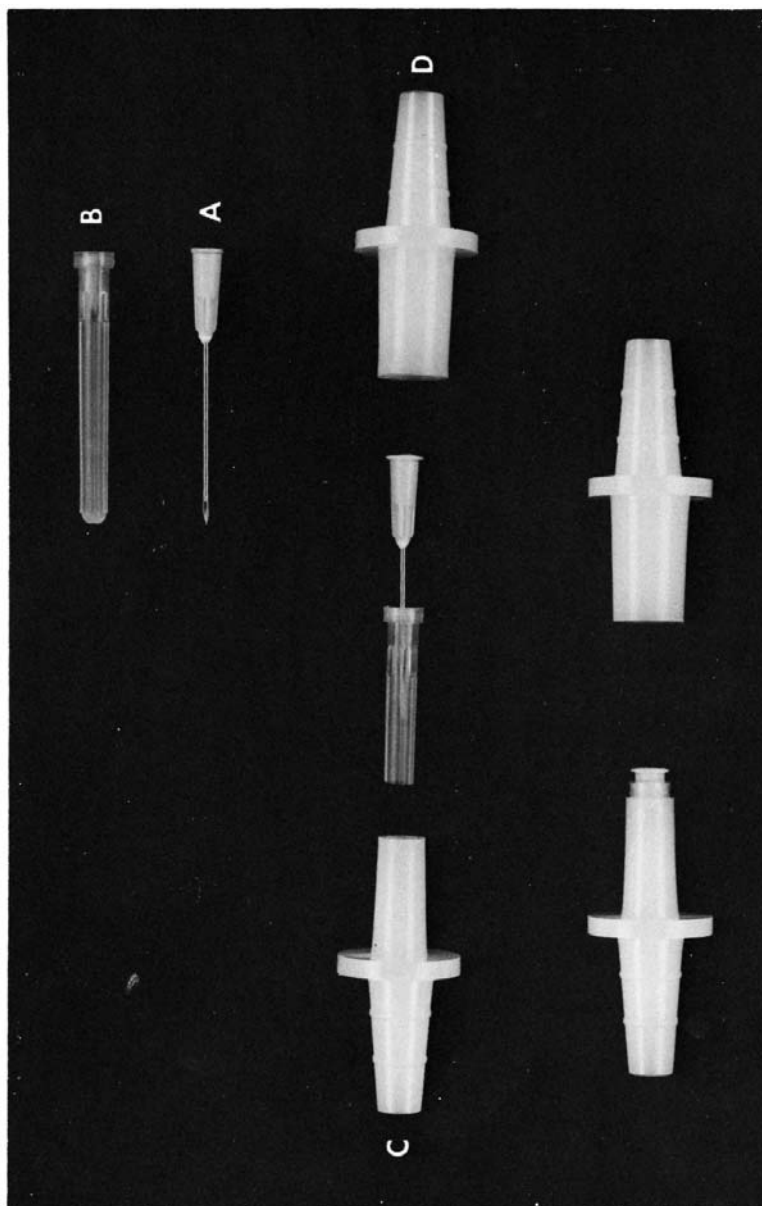

FIG. 3 Details of Construction of a Limiting Orifice with “Quick Disconnects” and Disposable Hypodermic Needles. (A) Disposable Needle, (B) Needle Sheath, (C) Male End of “Quick-Disconnect,” (D) Female End of “Quick-Disconnect”

10.2.1 *For Potentiometric Analysis:*

10.2.1.1 With the tube in a vertical position and the lower end capped pipet in 5.0 mL of 1+1 TISAB buffer. (See 8.10.)

10.2.1.2 Gently agitate the tube to wet all surfaces and empty the tube into a clean high-pressure linear polyethylene (or polypropylene or TFE-fluorocarbon) beaker.

10.2.1.3 Analyze using the potentiometric method given in Test Method D3269.

10.2.2 *For Semiautomated Analysis:*

10.2.2.1 With the tube in a vertical position, the upper end open and the lower end capped, pipet in 5.0 mL of distilled water.

10.2.2.2 Gently agitate the tube to wet all surfaces and empty the tube into an 8.5-mL sample cup.

10.2.2.3 Analyze the sample using the semiautomated method given in Test Method D3270.

10.3 Preparation of Particulate Filters for Fluoride Analysis.

10.3.1 *For Potentiometric Analysis:*

10.3.1.1 Place particulate filters in clean 15 by 150-mm test tubes. Add 5.0 mL of 1 N H₂SO₄ (see 8.8) and mix for several seconds with a vortex mixer. Allow to stand for 5 min.

10.3.1.2 Add 5 mL of 1 N NaOH solution (8.6) and 10.0 mL of TISAB solution (8.10). Decant into a clean, short form, 50-mL beaker made of high-density, linear, polyethylene (or polypropylene or TFE-fluorocarbon) and dilute with an equal amount of TISAB buffer (8.10).

10.3.1.3 Analyze using the potentiometric method, given in Method **D3269**.

10.3.2 For Semiautomated Analysis:

10.3.2.1 Place the particulate filter in a clean test tube, pipet in 5.0 mL of 1 N H₂SO₄ (8.8) and mix for several seconds with a vortex mixer. Allow to stand for 5 min. Filter samples into an 8.5-mL sample cup.

10.3.2.2 Analyze the sample using the semiautomated method described in Test Method **D3270**. Prepare the standards for semiautomated analysts with 1-H₂SO₄ (8.8).

11. Calculations

11.1 Calculate the volume of air sampled in standard cubic metres for conditions of 25°C (77°F) and 101.3 kPa (29.92 in. Hg) in accordance with Test Method **D3267**.

11.2 Calculate the fluoride concentration in the atmosphere as follows:

$$\text{Fluoride, } \mu\text{g}/\text{m}^3 = (A - B)/C \quad (1)$$

where:

A = mass of fluoride in the sample, μg ,

B = mass of fluoride in the blank, μg , and

C = volume of gas sampled at 25°C (77°F) and 101.3 kPa (29.92 in. Hg), m³.

12. Precision and Bias (3)

12.1 *Precision*—The root mean square difference of duplicate bicarbonate-coated tubes within the range from 0.5 to 3.3 $\mu\text{g}/\text{m}^3$ of fluoride is 0.051 $\mu\text{g}/\text{m}^3$ of fluoride.

12.2 *Bias*—Recovery of known amounts of gaseous HF was better than 95 % with amounts of fluoride up to about 40 μg and at sampling periods of 15 to 120 min. Data on particulate fluoride are not sufficient to establish recovery under field conditions.

13. Keywords

13.1 ambient atmospheres; analysis; fluoride; gaseous fluoride; particulate fluoride; sampling

REFERENCES

- (1) Mandl, R. H., Weinstein, L. H., Weiskopf, G. J., and Major, J. L., "The Separation and Collection of Gaseous and Particulate Fluorides," Paper CP-25A, 2nd International Clean Air Congress, Washington, DC, Dec. 6 to 11, 1970.
- (2) Weinstein, L. H., and Mandl, R. H., "The Separation and Collection of Gaseous and Particulate Fluorides," VDI Berichte Nr. 164, 1971, pp. 53–63.
- (3) Pack, M. R., et al., "Determination of Gaseous and Particulate Inorganic Fluorides in the Atmosphere," *Symposium on Air Pollution Control, ASTM STP 281*, ASTM, 1959.
- (4) Stern, A. C., ed., *Air Pollution, Volume II, Analysis, Monitoring, and Surveying*, Academic Press, New York, NY, 2nd ed., 1968, p. 70.
- (5) Lodge, J. P., Jr., ed., "Methods of Air Sampling and Analysis," Intersociety Committee, Lewis Publishers, Inc., 3rd ed. 1989, pp. 347–351.

ASTM International takes no position respecting the validity of any patent rights asserted in connection with any item mentioned in this standard. Users of this standard are expressly advised that determination of the validity of any such patent rights, and the risk of infringement of such rights, are entirely their own responsibility.

This standard is subject to revision at any time by the responsible technical committee and must be reviewed every five years and if not revised, either reapproved or withdrawn. Your comments are invited either for revision of this standard or for additional standards and should be addressed to ASTM International Headquarters. Your comments will receive careful consideration at a meeting of the responsible technical committee, which you may attend. If you feel that your comments have not received a fair hearing you should make your views known to the ASTM Committee on Standards, at the address shown below.

This standard is copyrighted by ASTM International, 100 Barr Harbor Drive, PO Box C700, West Conshohocken, PA 19428-2959, United States. Individual reprints (single or multiple copies) of this standard may be obtained by contacting ASTM at the above address or at 610-832-9585 (phone), 610-832-9555 (fax), or service@astm.org (e-mail); or through the ASTM website (www.astm.org). Permission rights to photocopy the standard may also be secured from the Copyright Clearance Center, 222 Rosewood Drive, Danvers, MA 01923, Tel: (978) 646-2600; http://www.copyright.com/