



# Standard Test Method for Fatigue Properties of Adhesives in Shear by Tension Loading (Metal/Metal)<sup>1</sup>

This standard is issued under the fixed designation D3166; the number immediately following the designation indicates the year of original adoption or, in the case of revision, the year of last revision. A number in parentheses indicates the year of last reapproval. A superscript epsilon ( $\epsilon$ ) indicates an editorial change since the last revision or reapproval.

*This standard has been approved for use by agencies of the U.S. Department of Defense.*

## 1. Scope

1.1 This test method covers the measurement of fatigue strength in shear by tension loading of adhesives on a standard specimen and under specified conditions of preparation, loading, and testing.

1.2 The values stated in SI units are to be regarded as the standard. The values given in parentheses are for information only.

1.3 *This standard does not purport to address all of the safety concerns, if any, associated with its use. It is the responsibility of the user of this standard to establish appropriate safety and health practices and determine the applicability of regulatory limitations prior to use.*

## 2. Referenced Documents

2.1 *ASTM Standards:*<sup>2</sup>

[D907 Terminology of Adhesives](#)

[D1002 Test Method for Apparent Shear Strength of Single-Lap-Joint Adhesively Bonded Metal Specimens by Tension Loading \(Metal-to-Metal\)](#)

## 3. Terminology

3.1 *Definitions*—Many terms in this test method are defined in Terminology [D907](#).

## 4. Significance and Use

4.1 While this test method is intended for use in metal-to-metal applications it may be used for measuring the fatigue properties of adhesives using plastic adherends, provided consideration is given to the thickness of the plastic adherends.

<sup>1</sup> This test method is under the jurisdiction of ASTM Committee [D14](#) on Adhesives and is the direct responsibility of Subcommittee [D14.80](#) on Metal Bonding Adhesives.

Current edition approved Oct. 1, 2012. Published October 2012. Originally approved in 1973. Last previous edition approved in 2005 as D3166 – 99 (2005). DOI: 10.1520/D3166-99R12.

<sup>2</sup> For referenced ASTM standards, visit the ASTM website, [www.astm.org](http://www.astm.org), or contact ASTM Customer Service at [service@astm.org](mailto:service@astm.org). For *Annual Book of ASTM Standards* volume information, refer to the standard's Document Summary page on the ASTM website.

Doublers may be required for plastic adherends to prevent bearing failure in the adherends.

4.2 A variation in the thickness of the adherends can influence the test results. For this reason, the thickness of the sheets used to make the test specimens should be specified in the material specification. When no thickness is specified, metal adherends 1.63 mm (0.064 in.) thick are recommended.

## 5. Apparatus

5.1 *Testing Machine*, capable of applying a sinusoidal cyclic axial load. The cyclic rate and type of equipment (constant load or constant displacement) can influence test results. For this reason, the cyclic rate and equipment should be specified in the material specification. When no cyclic rate is specified 1800 cycles/min is recommended. Employ suitable grips and jaws so that the specimen can be gripped tightly and held in alignment as the load, accurate within  $\pm 2\%$ , is applied.

## 6. Test Specimens

6.1 Use test specimens conforming to the shape and dimensions shown in [Fig. 1](#), having grip ends suitable for use in the particular testing machine. These specimens are similar to the tension lap-shear specimens described in Test Method [D1002](#).

6.2 Test at least 25 specimens shall be tested, representing at least 4 different panels.

6.3 Prepare, cut, finish, and condition the specimens in the same manner as for Test Method [D1002](#). Employ an overlap of 9.5 mm (0.38 in.) for 1.63-mm (0.064-in.) aluminum alloys. Ensure that the dimensions of other materials are such that failures occur in the bond. (An overlap of 12.7 mm (0.50 in.) for 6.4-mm (0.25-in.) thick nonmetals should be used if possible.)

## 7. Procedure

7.1 Unless otherwise specified, test the specimens in an atmosphere maintained at  $50 \pm 4\%$  relative humidity and  $23 \pm 1.1^\circ\text{C}$  ( $73.5 \pm 2^\circ\text{F}$ ). Precondition the specimens for at least 16 h.

7.2 Place the specimen in the jaws of the testing machine and grip tightly so that the specimen and the jaws are perfectly

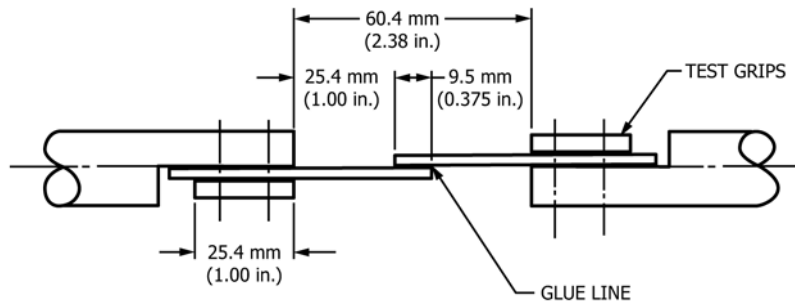

NOTE 1—Minimum specimen length in the grip 25.4 mm (1 in.).

FIG. 1 Test Specimen

aligned in such a position that an imaginary vertical line would pass through the center of the bonded area and through the points of suspension (Fig. 1). Ensure that the edge of the lap is 25.4 mm (1 in.) from the edge of the grip. Apply the cyclic load, ranging from a maximum to approximately 10 % of the maximum, and check periodically. The maximum load selected will depend upon the strength of the adhesive in shear tension loading and the desired life.

7.3 Test five specimens each at five or more maximum loads selected such that failures occur with regular spacing over a range varying from at least 10 000 000 cycles to not less than 2000 cycles. (As a guide, the initial maximum load may be 50 % of the strength of the adhesive in shear by tension loading.)

7.4 Record the number of cycles to failure and the corresponding loads, calculated in megapascals (pounds-force per square inch). Measure the specimen bond dimensions accurately enough to calculate the area to the nearest 0.6 mm (0.01 in.<sup>2</sup>). The location of failure (adhesive or joint material), and nature of failure if in the adhesive, (amounts of cohesion, adhesion, or contact failures) should be recorded for each specimen.

## 8. Report

8.1 Report the following:

8.1.1 Complete identification of the materials, procedures, and equipment (constant load or constant displacement) used.

8.1.2 Dimensions of the bond area including width and length  $\pm 2.5$  mm (0.01 in.) and bonding thickness  $\pm 0.0127$  mm (0.0005 in.). The method of obtaining the thickness of the

adhesive layer shall be described including procedure, location of measurements, and range of measurements.

8.1.3 Temperature and relative humidity in the test room.

8.1.4 Cycling rate in cycles per minute.

8.1.5 Number of cycles to failure and corresponding loads calculated in megapascals (pounds-force per square inch) recorded on stress-log cycle coordinates. The point at which the curve intercepts the 10 million cycle coordinate shall be designated as the “fatigue strength at 10 million cycles.”

8.1.6 Conditioning procedure used for specimens prior to testing.

8.1.7 Number of specimens tested.

8.1.8 Location and nature of failure (relative percentage of adhesive or adherend, adhesion, or contact) for each specimen if it occurs before the fatigue test is completed.

## 9. Precision and Bias

9.1 No information is presented on either precision or bias for Test Method D3166 since test results are non-quantitative.

9.2 The precision and bias of this test method are a function of the adhesive system, surface preparation, substrates, test temperature, cyclic stress level, and other factors related to the test apparatus, laboratory, and operator variabilities. Precision shall be reported in terms of the standard deviation of the data and the standard error of the mean.

## 10. Keywords

10.1 adhesive; fatigue; shear; single-lap joint; tension loading

*ASTM International takes no position respecting the validity of any patent rights asserted in connection with any item mentioned in this standard. Users of this standard are expressly advised that determination of the validity of any such patent rights, and the risk of infringement of such rights, are entirely their own responsibility.*

*This standard is subject to revision at any time by the responsible technical committee and must be reviewed every five years and if not revised, either reapproved or withdrawn. Your comments are invited either for revision of this standard or for additional standards and should be addressed to ASTM International Headquarters. Your comments will receive careful consideration at a meeting of the responsible technical committee, which you may attend. If you feel that your comments have not received a fair hearing you should make your views known to the ASTM Committee on Standards, at the address shown below.*

*This standard is copyrighted by ASTM International, 100 Barr Harbor Drive, PO Box C700, West Conshohocken, PA 19428-2959, United States. Individual reprints (single or multiple copies) of this standard may be obtained by contacting ASTM at the above address or at 610-832-9585 (phone), 610-832-9555 (fax), or service@astm.org (e-mail); or through the ASTM website (www.astm.org). Permission rights to photocopy the standard may also be secured from the Copyright Clearance Center, 222 Rosewood Drive, Danvers, MA 01923, Tel: (978) 646-2600; http://www.copyright.com/*