



Standard Test Method for Testing Stop-Leak Additives for Engine Coolants¹

This standard is issued under the fixed designation D3147; the number immediately following the designation indicates the year of original adoption or, in the case of revision, the year of last revision. A number in parentheses indicates the year of last reapproval. A superscript epsilon (ϵ) indicates an editorial change since the last revision or reapproval.

This standard has been approved for use by agencies of the U.S. Department of Defense.

1. Scope

1.1 This test method covers screening procedures for the preliminary evaluation of leak-stopping materials intended for use in engine cooling systems. (Heavy-duty users are referred to X1.2.21 in Specification D4485 for additional information.)

1.2 The values stated in SI units are to be regarded as the standard. The values given in parentheses are for information only.

1.3 *This standard does not purport to address all of the safety concerns, if any, associated with its use. It is the responsibility of the user of this standard to establish appropriate safety and health practices and determine the applicability of regulatory limitations prior to use.* Specific warning statements are given in 10.1.

2. Referenced Documents

2.1 *ASTM Standards:*²

D1176 Practice for Sampling and Preparing Aqueous Solutions of Engine Coolants or Antirusts for Testing Purposes

3. Terminology

3.1 *Definitions of Terms Specific to This Standard:*

3.1.1 *leaking*—frequent drops forming (more than 5 drops/min).

3.1.2 *sealed*—completely plugged with no leaking or seeping.

3.1.3 *seeping*—occasional drops forming (fewer than 5 drops/min).

4. Summary of Test Method

4.1 A heated test solution is circulated through a pressurized cubical metal reservoir which contains a slit and holes to

¹ This test method is under the jurisdiction of ASTM Committee D15 on Engine Coolants and Related Fluids and is the direct responsibility of Subcommittee D15.09 on Simulated Service Tests.

Current edition approved May 1, 2013. Published June 2013. Originally approved in 1972. Last previous edition approved in 2006 as D3147 – 06. DOI: 10.1520/D3147-06R13.

² For referenced ASTM standards, visit the ASTM website, www.astm.org, or contact ASTM Customer Service at service@astm.org. For *Annual Book of ASTM Standards* volume information, refer to the standard's Document Summary page on the ASTM website.

simulate leaks in an engine cooling system. The effectiveness of the stop-leak material is measured by its ability to seal the leaks under the prescribed conditions of flow rate, temperature, pressure, and time.

4.2 The presence of particles in the test material that are larger than 0.84 mm (0.033 in.) or the presence of gumming or gelling in stop-leak additives is determined by screening a test solution through a 850- μ m (U.S. No. 20) standard sieve. The screening is done both before and after the circulating test. Particles that remain on the sieve may be too large to pass through some passages of the cooling system.

5. Significance and Use

5.1 The screening procedures simulate the conditions of temperature, pressure, and circulation encountered in service. This test method will indicate whether a product is suitable for further evaluation in vehicles.

6. Apparatus (See Fig. 1)

6.1 Reservoir:

6.1.1 The reservoir shall be constructed of stainless steel, aluminum, or brass, 260 by 175 by 260-mm (10 by 7 by 10 in.) high, and the total capacity of the assembled unit shall be between 12 and 13.5 L (3.2 to 3.6 gal). The reservoir shall have a 20-mm ($\frac{3}{4}$ -in.) flange at the top, to which a cover plate is fitted.

6.1.2 The reservoir and cover shall have a minimum thickness of 1.6 mm (0.06 in.) in order to withstand a pressure of 140 kPa (20 psi).

6.1.3 A drain shall be located either on one side or the bottom of the reservoir to facilitate drainage of the test solution. The reservoir outlet to the circulating pump (suction side) shall be located near the bottom of Side C. The reservoir inlet from the circulating pump (discharge side) shall be located near the top of Side D. A 13-mm ($\frac{1}{2}$ -in.) elbow shall be welded to the reservoir inlet opening (inner surface of Side D) so that the liquid flow is directed towards Side A.

6.1.4 The cover plate of the reservoir shall be attached with bolts and sealed with neoprene gasket material. Openings accommodate a pressure gage (0 to 10 kPa (0 to 30 psi) minimum)/vent valve assembly.

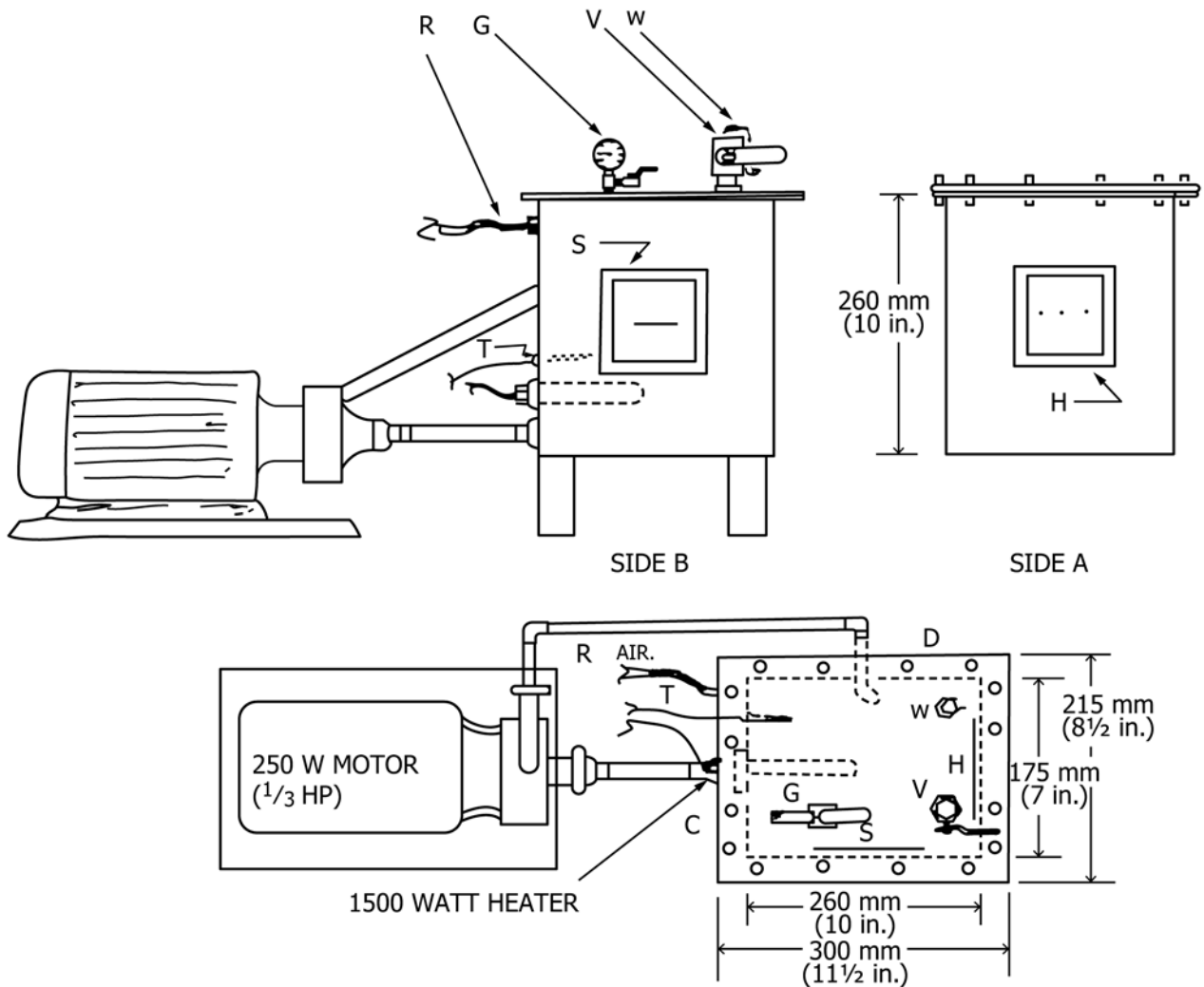

A,B,C,D—Sides of reservoir
 G—Pressure gage, 0-210 kPa, (0-30 psi)
 H—Brass test section, holes
 S—Brass test section, slit

R—Regulated air, 103 kPa (15 psi)
 T—Thermocouple foil, temperature controller, and well
 V—Fill opening (ball valve)
 W—Pressure relief valve, 137 kPa (20 psi)

FIG. 1 Leak Test Apparatus

6.1.5 Openings, 64 by 64 mm (2½ by 2½ in.), centered on Side A and Side B accommodate test plates (as described in Section 7). An inlet for regulated air at 103 ± 14 kPa (15 ± 2 psi) and a thermocouple probe are shown in Side C.

6.1.6 A liquid collection pan or pans shall be placed under the reservoir in a position that will allow collection of coolant that has leaked from test openings during operation of the apparatus. A transparent safety shield shall enclose the reservoir fully. This shield will be arranged to deflect any spray into the collection pans. The safety shield *must* be in place any time the reservoir is hot or pressurized, or both.

6.2 *Circulation Pump*,³ capable of circulating a minimum of 30 L (8 gal) of water per minute against zero head pressure,

shall be used. The packing seal of the pump shall be capable of withstanding 140 kPa (20 psi) and 104°C (220°F). Inlet and outlet connections shall be not less than ½ in. (12 mm) standard water pipe.

6.3 *Heating Element*, shall be of the immersion cartridge type and shall have a power rating of approximately 1500 W. It shall be installed above the suction pipe of the circulation pump and shall be capable of heating the filled system to 88°C (190°F). A temperature controller shall be used with the thermocouple to control power to the heating element and coolant temperature. An electrical pressure switch should also be used to interrupt power to the heater, in the event that excess pressure is generated.

6.4 The reservoir should be equipped with a suitable pressure relief valve to prevent an over-pressure in the event of a problem with the regulated air source.

³ An Eastern Industries Model P34C, manufactured by Eastern Industries Division Laboratory for Electronics Inc., 1525 Concord Pike, Wilmington, DE 19803, and a Grainger's catalogue pump No. IP787 have been used successfully.

6.5 A means of interrupting power to the heater in the event of excessive fluid loss or overheating is necessary.

6.6 U.S.A. Standard Testing Sieve, per Specification E11-95, 850 μm in an 8 in. (203 mm) or 10 in. (254 mm) FH frame.

7. Test Plates (See Fig. 2)

7.1 The test plates shall be constructed of solid brass plates, 102 by 102 by 0.20 to 0.25 mm (4 by 4 by 0.008 to 0.010 in.), with bolt holes for attachment to the reservoir. Neoprene gasket material shall be used to seal the plates. A complete set shall consist of fifteen plates: two plates without test holes or slits, six plates with one slit each [12.7 mm long by 0.127, 0.254, 0.381, 0.508, 0.635 and 0.762 mm wide, respectively (0.5 in. long by 0.005, 0.010, 0.015, 0.020, 0.025 and 0.030 in.) (Note 1)], six plates with three holes each of the same size [0.127, 0.254, 0.381, 0.508, 0.635 and 0.762 mm (0.005, 0.010, 0.015, 0.020, 0.025 and 0.030 in.) in diameter], and one plate with nine holes [three holes 0.254-mm (0.010-in.) diameter, three

holes 0.508-mm (0.020-in.) diameter, and three holes 0.762-mm (0.030-in.) diameter], bored on a diagonal across the plate so that drainage from one hole will not flow across another hole.

NOTE 1—Alternatively, a single plate may be used with provision for varying the slit size with a shim arrangement.

8. Test Solutions

8.1 Stop Leak Material Added to Water—Add the amount of stop leak material recommended by the manufacturer to distilled water. Mix the solution well before testing.

8.2 Stop Leak Material Added to Engine Coolant Concentrate—Prepare a 33 $\frac{1}{3}$ % (Note 2) solution (by volume) of engine coolant using distilled water as the diluent. Add the amount of stop leak material recommended by the manufacturer. Mix the solution well before testing.

NOTE 2—Alternatively, a 50 % (by volume) solution or other dilutions may be used upon mutual consent of the parties involved.

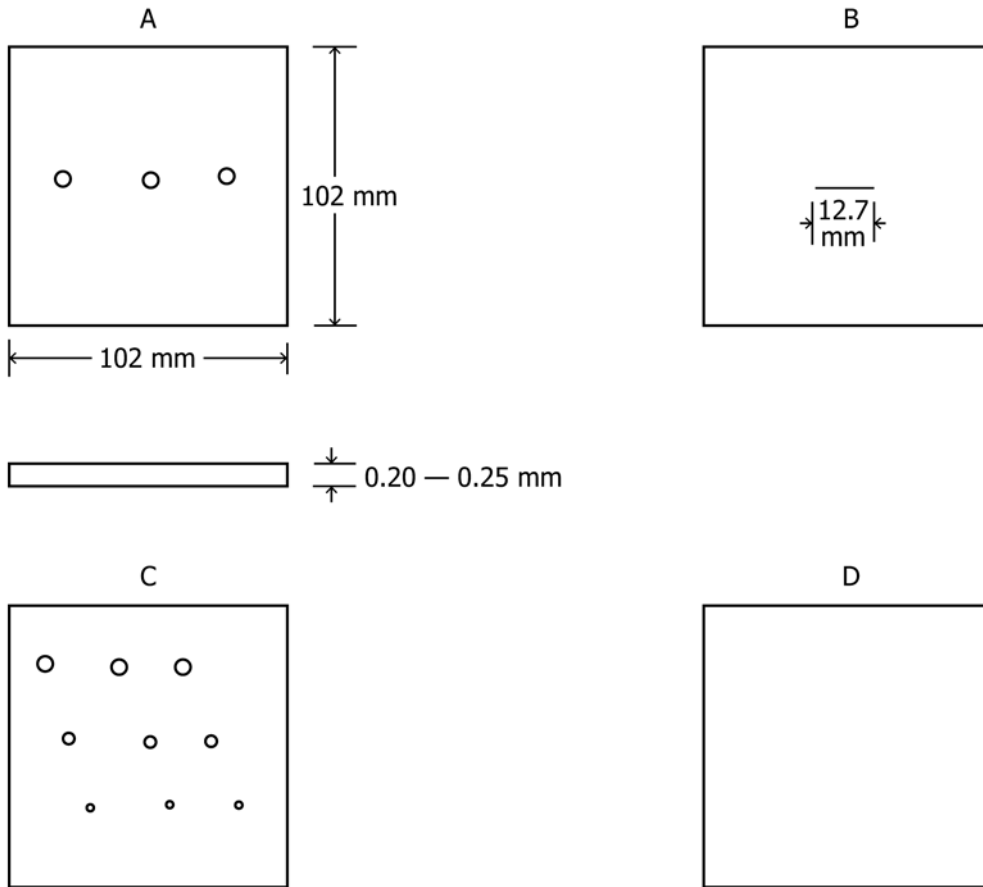

A—3 holes of appropriate diameter
 B—One 12.7-mm (1/2-in.) slit of appropriate width
 C—9 holes—3 each 0.254, 0.508, and 0.762 mm (0.010, 0.020, and 0.030 in.) in diameter (bored on a diagonal) so that drainage from one hole will not flow across another hole
 D—Solid

FIG. 2 Brass Test Panels

9. Sampling

9.1 The engine coolant shall be sampled in accordance with Test Method [D1176](#).

10. Procedure

10.1 **Warning**—the following procedures involve working with hot fluids and equipment. Review your intended procedure and the use of personal protective equipment with this in mind.

10.2 Particle Examination:

10.2.1 Stop-Leak Material Added to Water:

10.2.1.1 Place 200 mL of the test solution prepared in 8.1 in a 400-mL beaker. Heat the contents of the beaker to 88°C (190°F) while stirring, and allow the beaker to stand for 10 min.

10.2.1.2 Again heat to 88°C (190°F), stir until the contents are thoroughly mixed, and pour the contents through a 850- μ m (U.S. No. 20) standard sieve.

10.2.1.3 Rinse the beaker and sieve with 200 to 300 mL of hot [88°C (190°F)] distilled water.

10.2.1.4 Examine the sieve for any retained particles and for evidence of gumming or gelling. Record any observations.

10.3 Leak Tests:

10.3.1 Initial Screening Test:

10.3.1.1 Assemble the test unit with the solid test plate bolted over the opening on Side B and with the nine-hole screen test plate bolted over the opening on Side A, with the largest holes at the top. Bolt the top of the reservoir to the test unit.

10.3.1.2 Prepare the test solution according to the product manufacturer's recommendation. For example, a silica-based stop leak material may need to be tested in straight tap water, while most conventional stop leak materials are normally tested in a water/coolant mixture. Fill the unit with premixed test solution, and then withdraw 500 mL ([Note 3](#)).

10.3.1.3 Close the fill valve and vent valve, and then start the circulation pump. Adjust the pressure regulator gradually to bring the pressure in the test unit to 103 \pm 15 kPa (15 \pm 2 psi). Determine the largest hole size on the screen test plate in which leakage was stopped.

10.3.1.4 Turn off the circulation pump and air regulator. Use the vent valve to gradually release the pressure in the unit. Drain the test unit, and remove the test plates. Clear all screen test plate openings.

10.3.2 Final Leak Test:

10.3.2.1 Reassemble the test unit with the plates containing holes and slot one size larger than the holes plugged on the screen test plate. For example, if the 0.508-mm (0.020-in.) holes were plugged on the screen test, but not the 0.762-mm (0.030-in.) holes, start the final leak test with the plates with the 0.635-mm (0.025-in.) holes and slot. Install the plate with the holes on Side A and the plate with the slot on Side B.

10.3.2.2 Make sure vent valves are open and drain valves are closed, and fill the unit with pre-mixed solution. Keep in mind the volume of the unit, and leave 500 to 1000 mL of head space to allow for thermal expansion.

NOTE 3—Once the capacity of the machine is established, it may be

filled with the prescribed amount to bring it to 500 mL less than totally full. This will allow for thermal expansion of the test solution.

10.3.2.3 Start the circulation pump, and turn the heating unit on.

10.3.2.4 When the temperature reaches 88 \pm 3°C (190 \pm 5°F), pressurize the unit gradually with the air regulator to 103 \pm 15 kPa (15 \pm 2 psi). If the stop leak material is not at all capable of making a seal in the openings selected, the working volume of test solution will be lost rapidly, down to the level of the holes and slot. If this is the case, turn the air pressure, heater, and pump off. Replace the test plates with those with smaller holes or slot, or both, as needed, and restart at [10.3.2.2](#). Continue changing the plates and restarting the test as needed, until seals are made in both test plates without a total loss of the working volume of test solution.

10.3.2.5 When both plates are sealed successfully, operate the unit at temperature and pressure for 2 h. Turn the pump and heater off after 2 h. Leave the system under pressure for 16 \pm 4 h.

10.3.2.6 Observe the unit after 16 \pm 4 h. Turn the air regulator off, and release any residual pressure with the vent valve. Record the volume of any additional test solution lost to the collection pan. Two outcomes are possible: an ineffective seal, or an effective seal.

(1) The working volume of test solution will have been lost if an ineffective seal was made. In this case, replace either or both plates that failed to hold a seal with a plate having one size smaller openings, and return to [10.3.2.2](#).

(2) Less than half the working volume of test solution will be lost if an effective seal was made. If this is the case, advance to [10.3.2.7](#) without refilling.

10.3.2.7 Turn the pump and heating unit on. When the temperature reaches 88 \pm 4°C (190 \pm 5°F), apply pressure gradually to 103 \pm 15 kPa (15 \pm 2 psi). Stop the test if either test plate fails to maintain a seal so that the entire working volume of test solution is lost, and replace the leaking plate(s) as needed with one size smaller. Return to [10.3.2.2](#). Advance to [10.3.2.8](#) if less than the total volume of test solution is lost.

10.3.2.8 Turn the pump and heating unit off, and release the air pressure. Allow the test solution to cool to room temperature. Pressurize the system gradually to 103 \pm 15 kPa (15 \pm 2 psi) for 1 h. If continuing leakage causes the complete loss of working test solution during this hour, replace the leaking plates with smaller openings, and return to [10.3.2.2](#).

10.3.2.9 Turn the air pressure off and open the vent valve after 1 h. The leak test is considered complete when the blockages formed in the test plates permit this entire test sequence to be performed without being interrupted by a total loss of the working volume of test solution. Any step that causes a total loss of working test solution will result in a plate replacement and a restart at [10.3.2.2](#). Record the hole size, slot size, and cumulative volume of test solution lost during the successfully completed test run.

10.3.2.10 Drain the test unit. Remove the reservoir cover and test plates. Clean and flush the unit to remove all particles of stop leak material. Flush the circulating pump by running it with clean water. Clean the test plates with scouring powder

and a bristle brush. Clear all test plate openings, and rinse off all traces of scouring powder.

11. Report

11.1 Report the following information:

11.1.1 The largest diameter hole and widest slot sealed by the stop-leak material. Describe the quality of the seal. (See Section 5 for descriptions of the effectiveness of the seal.)

11.1.2 The total volume of test solution lost during the successfully completed leak test sequence.

11.1.3 Evidence of gumming or gelling or large particles observed on the 850- μm (U.S. No. 20) standard sieve.

12. Precision and Bias

12.1 *Repeatability*— Duplicate results shall not be considered suspect unless they differ by more than 0.127 mm (0.005 in.).

12.2 *Reproducibility*— Reported results should agree within 0.127 mm (0.005 in.) of median-holes, 85 % confidence level, slits, 99 % confidence level.

12.3 *Bias*— Since there is no accepted reference material suitable for determining the bias for the procedure in this test method, bias has not been determined.

13. Other Tests

13.1 Tests that are required to check the effect of stop-leak compound on other properties of coolants, such as corrosiveness and cavitation effects, may be conducted by standard published ASTM procedures for testing engine coolants.

14. Keywords

14.1 engine coolants; stop-leak additives

ASTM International takes no position respecting the validity of any patent rights asserted in connection with any item mentioned in this standard. Users of this standard are expressly advised that determination of the validity of any such patent rights, and the risk of infringement of such rights, are entirely their own responsibility.

This standard is subject to revision at any time by the responsible technical committee and must be reviewed every five years and if not revised, either reapproved or withdrawn. Your comments are invited either for revision of this standard or for additional standards and should be addressed to ASTM International Headquarters. Your comments will receive careful consideration at a meeting of the responsible technical committee, which you may attend. If you feel that your comments have not received a fair hearing you should make your views known to the ASTM Committee on Standards, at the address shown below.

This standard is copyrighted by ASTM International, 100 Barr Harbor Drive, PO Box C700, West Conshohocken, PA 19428-2959, United States. Individual reprints (single or multiple copies) of this standard may be obtained by contacting ASTM at the above address or at 610-832-9585 (phone), 610-832-9555 (fax), or service@astm.org (e-mail); or through the ASTM website (www.astm.org). Permission rights to photocopy the standard may also be secured from the Copyright Clearance Center, 222 Rosewood Drive, Danvers, MA 01923, Tel: (978) 646-2600; <http://www.copyright.com/>