



# Standard Test Method for Solvent-Extractable Material in Black Pigments<sup>1</sup>

This standard is issued under the fixed designation D305; the number immediately following the designation indicates the year of original adoption or, in the case of revision, the year of last revision. A number in parentheses indicates the year of last reapproval. A superscript epsilon ( $\epsilon$ ) indicates an editorial change since the last revision or reapproval.

*This standard has been approved for use by agencies of the U.S. Department of Defense.*

## 1. Scope

1.1 This test method covers the determination of the solvent-extractable material in black pigments such as carbon black, lampblack, and bone black.

1.2 The values stated in SI units are to be regarded as the standard. The values given in parentheses are for information only.

1.3 *This standard does not purport to address all of the safety concerns, if any, associated with its use. It is the responsibility of the user of this standard to establish appropriate safety and health practices and determine the applicability of regulatory limitations prior to use.*

## 2. Referenced Documents

- 2.1 *ASTM Standards*:<sup>2</sup>  
[D329 Specification for Acetone](#)

## 3. Significance and Use

3.1 This test method is used by black pigment producers and users for product acceptance.

## 4. Apparatus

4.1 *Extraction Apparatus*, consisting of a flask, siphon cup, and a condenser similar to the apparatus shown in either [Fig. 1](#) or [Fig. 2](#).

NOTE 1—A Siphlet apparatus may be used as an alternative.

4.2 *Extraction Thimbles*—The thimble must be made of greaseless paper and be of correct size to fill the selected apparatus.

NOTE 2—The recommended thimble size for each of the apparatus shown in [Fig. 1](#) is listed below:

	Fig. 1	Fig. 2
Height	70 mm	62 mm
Inside diameter	28 mm	22 mm
Outside diameter	30 mm	24 mm

4.3 The thimbles are available in various heights and widths with two thickness levels, single thickness or double thickness. Single-thickness thimbles are recommended for this extraction procedure.

## 5. Reagents and Material

5.1 *Purity of Reagents*—Reagent grade chemicals shall be used in all tests. Unless otherwise indicated, it is intended that all reagents shall conform to the specifications of the Committee on Analytical Reagents of the American Chemical Society, where such specifications are available.<sup>3</sup> Other grades may be used, provided it is first ascertained that the reagent is of sufficiently high purity to permit its use without lessening the accuracy of the determination.

5.2 *Solvent*—Acetone and benzene are the most commonly used solvents (see [Specification D329](#)); however, other solvents may be used as agreed upon.

5.3 *Glass Wool*.

## 6. Procedure

6.1 Weight approximately 10 g of pigment (moisture-free) into a weighed thimble and record the weight to 0.1 g. For pigments with high apparent density (bone black, iron oxides, etc.) a 40-g sample is recommended. Plug the open end of the thimble with glass wool and place in the siphon cup. Add 200 to 250 mL of the solvent to the previously dried flask.

6.2 When using acetone as the extraction solvent, extract continuously for 4 h, heating at a rate such that the time required to fill and empty the siphon cup will not exceed 8 min. With other solvents extract for 16 h.

<sup>1</sup> This test method is under the jurisdiction of ASTM Committee D01 on Paint and Related Coatings, Materials, and Applications and is the direct responsibility of Subcommittee D01.31 on Pigment Specifications.

Current edition approved Dec. 1, 2014. Published December 2014. Originally approved in 1929. Last previous edition approved in 2008 as D305 – 84 (2008). DOI: 10.1520/D0305-84R14.

<sup>2</sup> For referenced ASTM standards, visit the ASTM website, [www.astm.org](http://www.astm.org), or contact ASTM Customer Service at [service@astm.org](mailto:service@astm.org). For *Annual Book of ASTM Standards* volume information, refer to the standard's Document Summary page on the ASTM website.

<sup>3</sup> *Reagent Chemicals, American Chemical Society Specifications*, American Chemical Society, Washington, DC. For Suggestions on the testing of reagents not listed by the American Chemical Society, see *Analar Standards for Laboratory Chemicals*, BDH Ltd., Poole, Dorset, U.K., and the *United States Pharmacopeia and National Formulary*, U.S. Pharmacopeial Convention, Inc. (USPC), Rockville, MD.

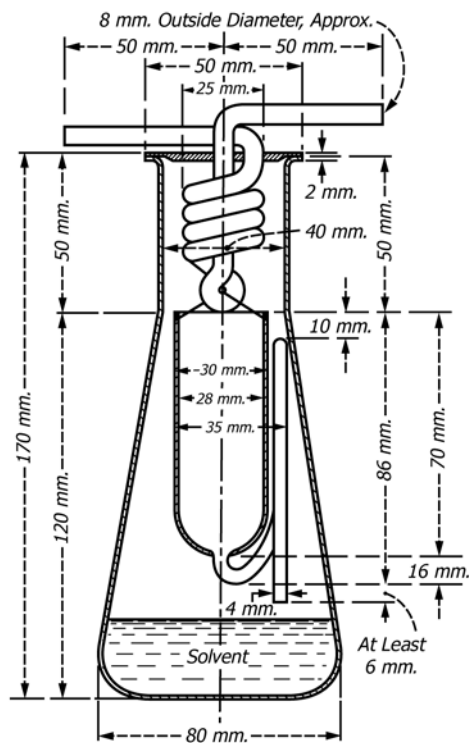

FIG. 1 Extraction Apparatus

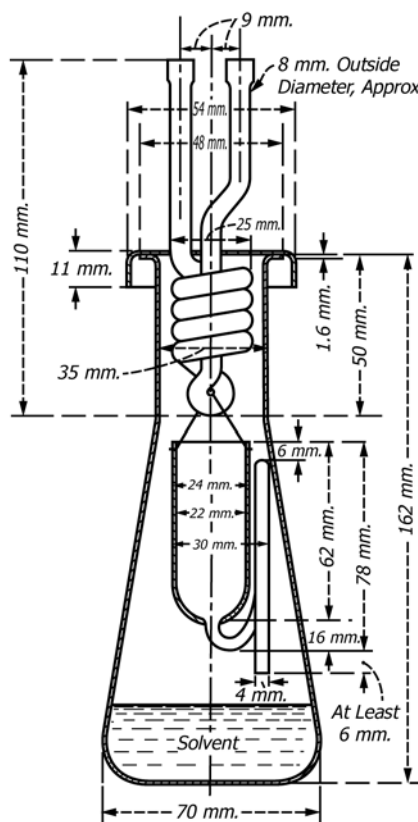

FIG. 2 Extraction Apparatus

NOTE 3—If particles of carbon have escaped from the cup into the extraction liquid, filter the liquid, wash the paper with solvent, and return the total filtrate to the extraction flask, prior to continuing with 6.3.

6.3 Transfer quantitatively the extract solution to a 400-mL beaker that has been weighed to the nearest 0.1 g, and evaporate off the solvent on a steam bath or plate. Remove the beaker from the bath or hot plate just before the last trace of the solvent disappears. Dry the dish for 1 h at 105°C (221°F). Cool and weigh to the nearest 0.1 g.

## 7. Calculation

7.1 Calculate the percent extractable material,  $E$ , to the nearest 0.05 % as follows:

$$E = [(R - B)/(S - W)] \times 100 \quad (1)$$

where:

$R$  = weight of extractable material and weighed dish, g,

$B$  = weight of weighed dish, g,

$S$  = weight of thimble and specimen, g, and

$W$  = weight of thimble, g.

## 8. Precision

8.1 Precision data are not available at this time. When they are available the appropriate precision statements will be added.

## 9. Keywords

9.1 black pigment; solvent extractable

ASTM International takes no position respecting the validity of any patent rights asserted in connection with any item mentioned in this standard. Users of this standard are expressly advised that determination of the validity of any such patent rights, and the risk of infringement of such rights, are entirely their own responsibility.

This standard is subject to revision at any time by the responsible technical committee and must be reviewed every five years and if not revised, either reapproved or withdrawn. Your comments are invited either for revision of this standard or for additional standards and should be addressed to ASTM International Headquarters. Your comments will receive careful consideration at a meeting of the responsible technical committee, which you may attend. If you feel that your comments have not received a fair hearing you should make your views known to the ASTM Committee on Standards, at the address shown below.

This standard is copyrighted by ASTM International, 100 Barr Harbor Drive, PO Box C700, West Conshohocken, PA 19428-2959, United States. Individual reprints (single or multiple copies) of this standard may be obtained by contacting ASTM at the above address or at 610-832-9585 (phone), 610-832-9555 (fax), or service@astm.org (e-mail); or through the ASTM website (www.astm.org). Permission rights to photocopy the standard may also be secured from the Copyright Clearance Center, 222 Rosewood Drive, Danvers, MA 01923, Tel: (978) 646-2600; http://www.copyright.com/