



Standard Test Methods for Structural Panels in Flexure¹

This standard is issued under the fixed designation D3043; the number immediately following the designation indicates the year of original adoption or, in the case of revision, the year of last revision. A number in parentheses indicates the year of last reapproval. A superscript epsilon (ϵ) indicates an editorial change since the last revision or reapproval.

1. Scope

1.1 These test methods determine the flexural properties of strips cut from structural panels or panels up to 4 by 8 ft in size. Structural panels in use include plywood, waferboard, oriented strand board, and composites of veneer and of wood-based layers. Four methods of tests are included:

	Sections
Method A—Center-Point Flexure Test	5
Method B—Two-Point Flexure Test	6
Method C—Pure Moment Test	7
Method D—Flexure Test for Quality Assurance	8

The choice of method will be dictated by the purpose of the test, type of material, and equipment availability. All methods are applicable to material that is relative uniform in strength and stiffness properties. Only Method C should be used to test material suspected of having strength or stiffness variations within a panel caused by density variations, knots, knot-holes, areas of distorted grain, fungal attack, or wide growth variations. However, Method B may be used to evaluate certain features such as core gaps and veneer joints in plywood panels where effects are readily projected to full panels. Method C generally is preferred where size of test material permits. Moments applied to fail specimens tested by Method A, B or D in which large deflections occur can be considerably larger than nominal. An approximate correction can be made.

1.2 *Method A, Center-Point Flexure Test*—This method is applicable to material that is uniform with respect to elastic and strength properties. Total deflection, and modulus of elasticity computed from it, include a relatively constant component attributable to shear deformation. It is well suited to investigations of many variables that influence properties uniformly throughout the panel in controlled studies and to test small, defect-free control specimens cut from large panels containing defects tested by the large-specimen method.

1.3 *Method B, Two-Point Flexure Test*—This method, like Method A, is suited to the investigation of factors that influence

strength and elastic properties uniformly throughout the panel, in controlled studies, and to testing small, defect free control specimens cut from large specimens tested by Method C. However, it may be used to determine the effects of finger joints, veneer joints and gaps, and other features which can be placed entirely between the load points and whose effects can be projected readily to full panel width. Deflection and modulus of elasticity obtained from this method are related to flexural stress only and do not contain a shear component. Significant errors in modulus of rupture can occur when nominal moment is used (see [Appendix X1](#)).

1.4 *Method C, Pure Moment Test*—This method is ideally suited for evaluating effects of knots, knot-holes, areas of sloping grain, and patches for their effect on standard full-size panels. It is equally well suited for testing uniform or clear material whenever specimen size is adequate. Measured deformation and elastic constants are free of shear deformation effects; and panels can be bent to large deflections without incurring errors from horizontal force components occurring in other methods. Specimen size and span above certain minimums are quite flexible. It is preferred when equipment is available.

1.5 *Method D, Flexure Test for Quality Assurance*—This method, like Method A, is well suited to the investigation of factors that influence bending strength and stiffness properties. Also like Method A, this method uses small specimens in a center-point simple span test configuration. This method uses a span to depth ratio, specimen width, test fixture and test speed that make the method well suited for quality assurance. The method is frequently used for quality assurance testing of oriented strand board.

1.6 All methods can be used to determine modulus of elasticity with sufficient accuracy. Modulus of rupture determined by Methods A, B or D is subject to errors up to and sometimes exceeding 20 % depending upon span, loading, and deflection at failure unless moment is computed in the rigorous manner outlined in [Appendix X1](#) or corrections are made in other ways. These errors are not present in Method C.

1.7 When comparisons are desired between results of specimen groups, it is good practice to use the same method of test for all specimens, thus eliminating possible differences relative to test method.

¹ These methods are under the jurisdiction of ASTM Committee D07 on Wood and are the direct responsibility of Subcommittee D07.03 on Panel Products.

Current edition approved Nov. 1, 2011. Published November 2011. Originally approved in 1972. Last previous edition approved in 2000 as D3043 – 00 (2006). DOI: 10.1520/D3043-00R11.

1.8 This standard does not purport to address all of the safety concerns, if any, associated with its use. It is the responsibility of the user of this standard to establish appropriate safety and health practices and determine the applicability of regulatory limitations prior to use.

2. Referenced Documents

2.1 ASTM Standards:²

D2395 Test Methods for Density and Specific Gravity (Relative Density) of Wood and Wood-Based Materials

D4442 Test Methods for Direct Moisture Content Measurement of Wood and Wood-Based Materials

D4761 Test Methods for Mechanical Properties of Lumber and Wood-Base Structural Material

3. Significance and Use

3.1 These methods give the flexural properties, principally strength and stiffness, of structural panels. These properties are of primary importance in most structural uses of panels whether in construction for floors, wall sheathing, roof decking, concrete form, or various space plane structures; packaging and materials handling for containers, crates, or pallets; or structural components such as stress-skin panels.

3.2 To control or define other variables influencing flexure properties, moisture content and time to failure must be determined. Conditioning of test material at controlled atmospheres to control test moisture content and determination of specific gravity are recommended. Comparisons of results of plywood, veneer composites, and laminates with solid wood or other plywood constructions will be greatly assisted if the thickness of the individual plies is measured to permit computation of section properties.

4. Control of Moisture Content

4.1 Structural panel samples to be tested at a specific moisture content or relative humidity shall be conditioned to approximate constant mass in controlled atmospheric conditions before testing. For structural panels used under dry conditions, a relative humidity of $65 \pm 5\%$ at a temperature of $68 \pm 6^\circ\text{F}$ ($20 \pm 3^\circ\text{C}$) is recommended.

5. Method A—Center-Point Flexure Test

5.1 *Summary*—A conventional compression testing machine is used to apply and measure a load at mid-span of a small flexure specimen; and the resulting deflection at mid span is measured or recorded. The test proceeds at a constant rate of head motion until either sufficient deflection data in the elastic range have been gathered or until specimen failure occurs. The specimen is supported on reaction bearings which permit the specimen and bearing plate to roll freely over the reactions as the specimen deflects.

5.2 *Test Specimen*—The test specimen shall be rectangular in cross section. The depth of the specimen shall be equal to the

thickness of material, and the width shall be 1 in. (25 mm) for depths less than $\frac{1}{4}$ in. (6 mm) and 2 in. (50 mm) for greater depths (**Note 1**). When the principal direction of the face plies, laminations, strands, or wafers is parallel to the span, the length of the specimen (**Note 2**) shall be not less than 48 times the depth plus 2 in.; when the principal direction of the face plies, laminations, strands, or wafers is perpendicular to the span, the specimen length shall be not less than 24 times the depth plus 2 in. (**Note 3**).

NOTE 1—In certain specific instances, it may be necessary or desirable to test specimens having a width greater than 1 or 2 in. (25 or 50 mm). To eliminate plate action when wider specimens are tested, the specimen width shall not exceed one third of the span length and precaution shall be taken to ensure uniform bearing across the entire width of the specimen at the load and reaction points.

NOTE 2—In cutting specimens to meet the length requirement, it is not intended that the length be changed for small variations in thickness. Rather, it is intended that the nominal thickness of the material under test should be used for determining the specimen length.

5.2.1 *Measurements*—Measure specimen thickness at mid-span at two points near each edge and record the average. Measure to the nearest 0.001 in. (0.02 mm) or 0.3 %. Measure width at mid-span to the nearest 0.3 %.

5.2.1.1 When needed for interpretation of test results for plywood, veneer composites, and laminates measure thickness of each layer to the nearest 0.001 in. (0.02 mm) at mid-span at each edge and record the average.

5.3 *Span*—The span shall be at least 48 times the nominal depth when the principal direction of the face plies, laminations, strands, or wafers of the test specimen is parallel to the span and at least 24 times the nominal depth when the principal direction of the face plies, laminations, strands, or wafers is perpendicular to the span (**Note 3**).

NOTE 3—Establishment of a span-depth ratio is required to allow an accurate comparison of test values for materials of different thicknesses. It should be noted that the span is based on the nominal thickness of the material and it is not intended that the spans be changed for small variations in thickness.

5.4 *End Supports*—Reaction points shall be capable of freely compensating for warp of the test specimen by turning laterally in a plane perpendicular to the specimen length so as to apply load uniformly across its width. Design of end supports shall place the center of rotation near the neutral axis of the specimen of average thickness. Construction is shown in detail in **Fig. 1**. Bearing points shall be rounded where they contact the specimen.

5.4.1 Use of bearing plates is generally recommended and is required wherever significant local deformation may occur.

5.4.2 Use of roller bearings or plates and rollers to preclude friction forces between end support and specimen is recommended in addition to the requirement of lateral compensation. Construction of a suitable end support using small roller bearings in conjunction with a plate which clips to the end of the specimen is illustrated in **Fig. 2** and **Fig. 3**. The use of a large ball bearing to provide lateral compensation for warp is also illustrated. This method is particularly recommended for thin specimens and small loads.

5.4.3 As the specimen deflects during test, loads no longer act in the direction assumed in formulas for calculating

² For referenced ASTM standards, visit the ASTM website, www.astm.org, or contact ASTM Customer Service at service@astm.org. For *Annual Book of ASTM Standards* volume information, refer to the standard's Document Summary page on the ASTM website.

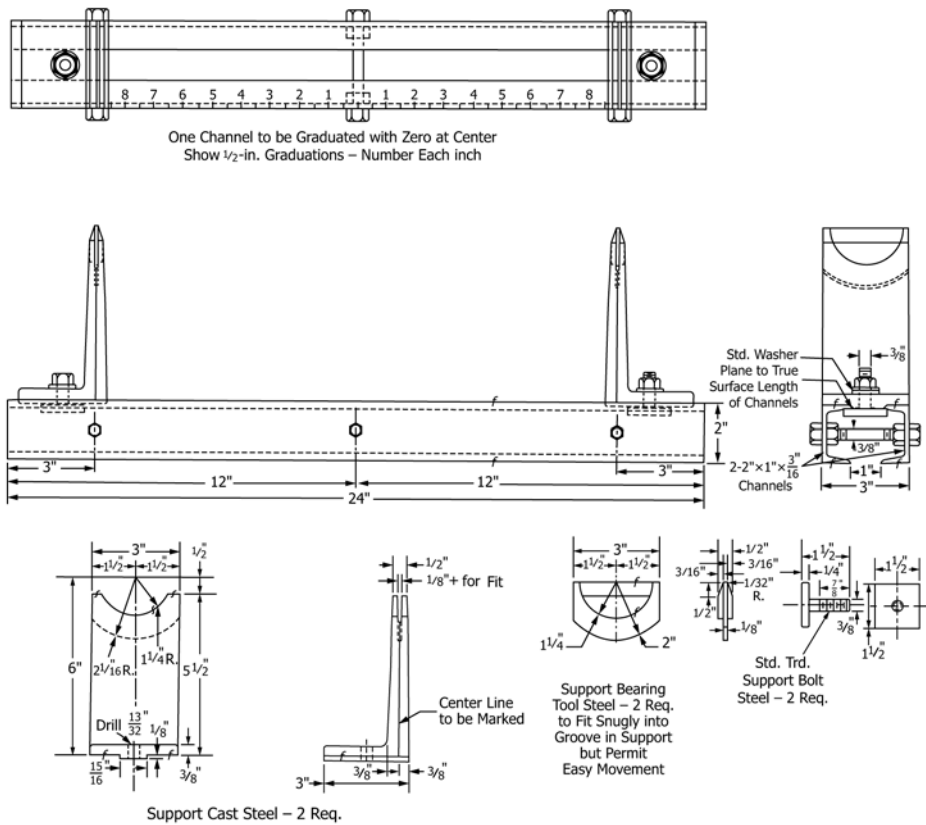

Inch-Pound (in.)	Metric Equiva- lents, (mm)	Inch-Pound (in.)	Metric Equiva- lents, (mm)
1/16	1.5	1/4	32
1/8	3	1/2	38
3/16	5	2	50
1/4	6	2 1/16	52
3/8	10	3	76
13/32	10.3	5 1/2	140
1/2	12	6	152
7/8	23	12	305
15/16	24	24	610
1	25		

FIG. 1 Apparatus for Static Bending Test Showing Details of Laterally Adjustable Supports

properties. For a discussion of these errors, their effects, and methods for reducing them, refer to [Appendix X1](#).

5.5 Loading Block—A loading block having a radius of curvature of approximately one and one-half times the depth of the test specimen for a chord length of not less than twice the depth of the specimen shall be used. In cases where excessive local deformation may occur, suitable bearing plates shall be used. Radius of curvature of bearing plate or block shall not be so large as to cause bridging as the specimen bends.

5.6 Loading Procedure—Apply the load with a continuous motion of the movable head throughout the test. The rate of load application shall be such that the maximum fiber strain rate is equal to 0.0015 in./in. (mm/mm) per min within a

permissible variation of $\pm 25\%$. Load shall be measured to an accuracy of $\pm 1\%$ of indicated value or 0.4 percent of full scale, whichever is larger. Calculate the rate of motion of the movable head as follows:

$$N = zL^2/6d \quad (1)$$

where:

- N = rate of motion of moving head, in./min (mm/min),
- L = span, in. (mm),
- d = depth of beam, in. (mm), and
- z = unit rate of fiber strain, in./in.·min (mm/mm·min) of outer fiber length = 0.0015.

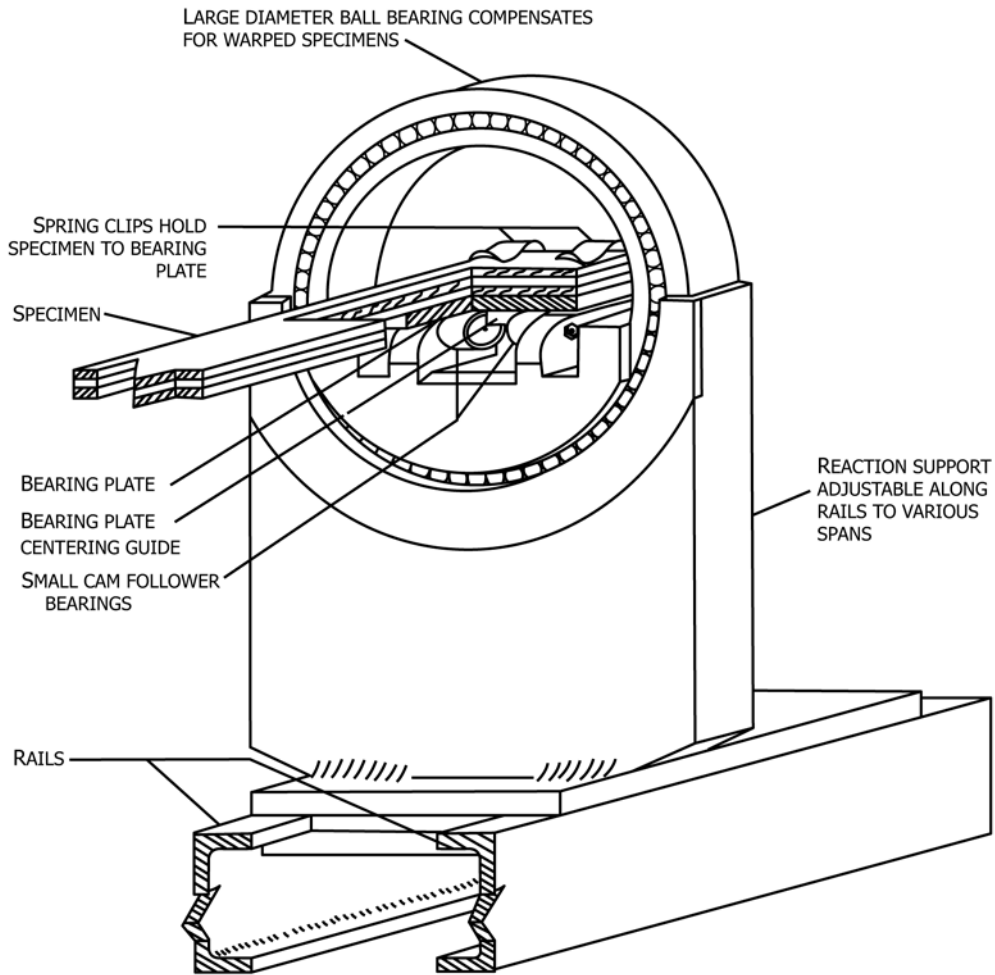

FIG. 2 Reaction Bearing for Small Flexure Test Specimens

5.6.1 Measure the elapsed time from initiation of loading to maximum load and record to the nearest 1/2 min.

5.7 *Measurement of Deflection*—Take data for load-deflection curves to determine the modulus of elasticity, proportional limit, work to proportional limit, work to maximum load, and total work. Take deflections by the methods indicated in Fig. 4 or Fig. 5, and take readings to the nearest 0.001 in. (0.02 mm). Choose increments of load so that not less than 12 and preferably 15 or more readings of load and deflection are taken to the proportional limit.

5.7.1 Deflections also may be measured with transducer-type gages and plotted simultaneously against load. In this case, record deflection to an accuracy of at least 1 1/2 % of deformation at proportional limit and the recorded trace below the proportional limit shall be at least 2 1/2 in. (64 mm) long or 1/4 of full scale measured on the deformation axis, whichever is larger. Similar requirements apply to the load axis.

5.8 *Calculations:*

5.8.1 Calculate specimen bending stiffness as follows:

$$EI = (L^3 / 48)(P/\Delta) \quad (2)$$

where:

EI = modulus of elasticity, psi (MPa) × moment of inertia, in.⁴ (or mm⁴),

P/Δ = slope of load—deflection curve, lbf/in. (N/mm),

I = moment of inertia, in.⁴ (mm⁴), and

L = span, in. (mm).

5.8.1.1 Moment of inertia used in the computations in 5.8.1 may be calculated in several different ways depending upon the requirements of the investigation. It may be based on the entire cross section, may include only the moment of inertia of layers parallel to span, or may include all layers weighted in accordance with modulus of elasticity in the direction of bending stress. State clearly the method employed in the report.

5.8.2 Calculate maximum moment ($S_b I/c$) by the following equation:

$$S_b I/c = PL/4 \quad (3)$$

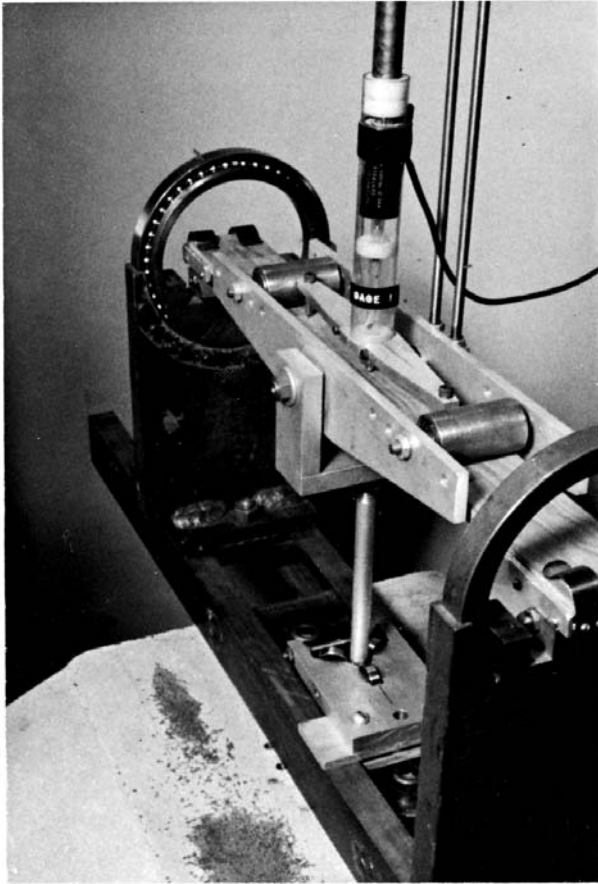

FIG. 3 Apparatus for Two-Point Loading and Measurement of Deflection (Method B)

where:

- $S_b I/c$ = maximum moment, lbf-in. (N-mm),
- S_b = modulus of rupture, psi (MPa),
- P = maximum load, lbf (N), and
- c = distance from neutral axis to extreme fiber, in. (mm).

6. Method B—Two-Point Flexure Test

6.1 *Summary*—The ends of a two-point flexure specimen are supported on special reaction bearings which in turn rest on the table of a conventional testing machine. A pivoted loading device applies equal loads at points $1/4$ of span from the reactions resulting from downward motion of the testing machine crosshead, and subjects the middle half of the specimen to conditions of nearly pure moment. Deflection of mid span relative to two points just inside the load points is measured with a dial gage or transducer thus giving deformation due to pure bending and unaffected by shear deformation.

6.2 *Test Specimen*—The test specimen shall be rectangular in cross section and its length shall exceed by 2 in. (50 mm) the span on which it is to be tested as determined in 6.3. Thickness shall be the thickness of the material. Width shall be 1 in. (25 mm) for material less than $1/4$ in. (6 mm) thick and 2 in. for material $1/4$ in. and over in thickness. The alternate width is 12 in. (300 mm).

6.2.1 *Measurements*—Measure specimen thickness at mid-span at two points near each edge and record the average. Measurements shall be to the nearest 0.001 in. (0.02 mm) or 0.3 %. Measure width at mid-span to the nearest 0.3 %.

6.2.1.1 When needed for interpretation of test results for plywood, veneer composites, and laminates, measure thickness of each layer to the nearest 0.001 in. (0.02 mm) at mid-span at each edge and record the average.

6.3 *Span*—Span-depth ratio has relatively little influence on the results of tests using two-point loading and the method of measuring deformation described for it in this standard. However, it is important that the distance between load point and adjacent support be sufficient to prevent rolling shear failures. The alternate 12-in. (300-mm) width will have a midlength (constant moment section) at least 12 in. in length.

6.3.1 Specimens tested for stiffness only shall have a span at least 48 times nominal thickness if the principal direction is parallel to span and 24 times nominal thickness if the principal direction is perpendicular to span.

6.3.2 It is recommended that two-point loading tests to failure be made on a span at least equal to the spacing between load points plus 48 times specimen thickness or 24 times specimen thickness for the principal direction parallel or perpendicular respectively. Material having high rolling shear strength or having all its plies, laminations, strands, or wafers parallel to span may use closer spacing between loads and supports.

6.4 *Supports*—Reaction supports shall meet the requirements of 5.4 and 5.4.1. Other comments as well as those of 5.4.2 and 5.4.3 apply.

6.5 *Loading*—Apply two equal loads to the specimen equidistant from the supports by cylindrical surfaces having a radius of curvature of at least $1\frac{1}{2}$ times specimen thickness wherever it may contact the specimen. The axes of these surfaces shall remain parallel and at least one of them shall be free to turn about its axis or be loaded through rollers to prevent the application of friction forces to the surface of the specimen. Construction of a satisfactory loading head is illustrated in Fig. 6 and Fig. 3. Locate the pivot point that equalizes the two loads near the original neutral axis of the specimen.

6.5.1 Space load points sufficiently to provide a deflection which can be adequately measured. A spacing of at least 24 and 12 times specimen thickness is recommended for specimens with the principal direction parallel and perpendicular to span respectively.

6.5.2 Measure the sum of the two loads to an accuracy of at least 1 % of indicated value or 0.4 % of full scale, whichever is larger.

6.6 *Speed of Test*—Apply load at a continuous rate of motion of the load points with respect to the supports within a permissible range of 25 % of the rate determined as follows:

$$N = (za/3d)(3L - 4a) \quad (4)$$

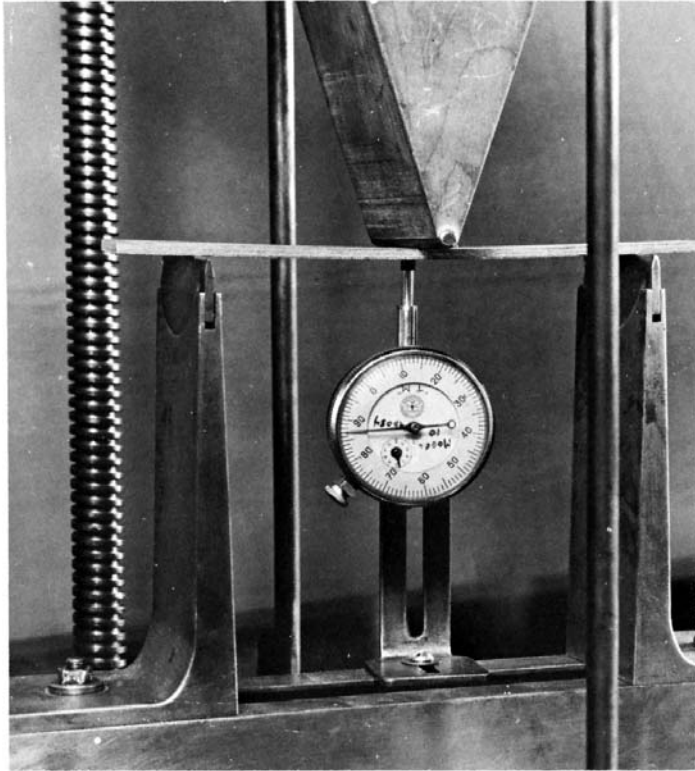

FIG. 4 Static Bending Test Showing Adjustable Supports and One Method of Attaching Dial Gage for Observing Deflection of Thin Material

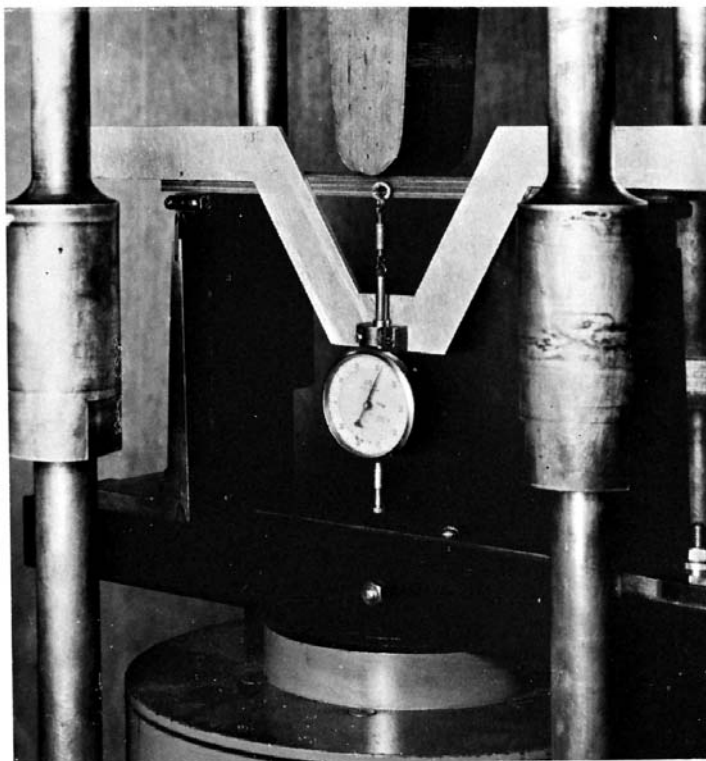

FIG. 5 Static Bending Test Showing Roller Bearing at Supports and Special Yoke with Dial Gage for Measuring Deflection at the Neutral Axis

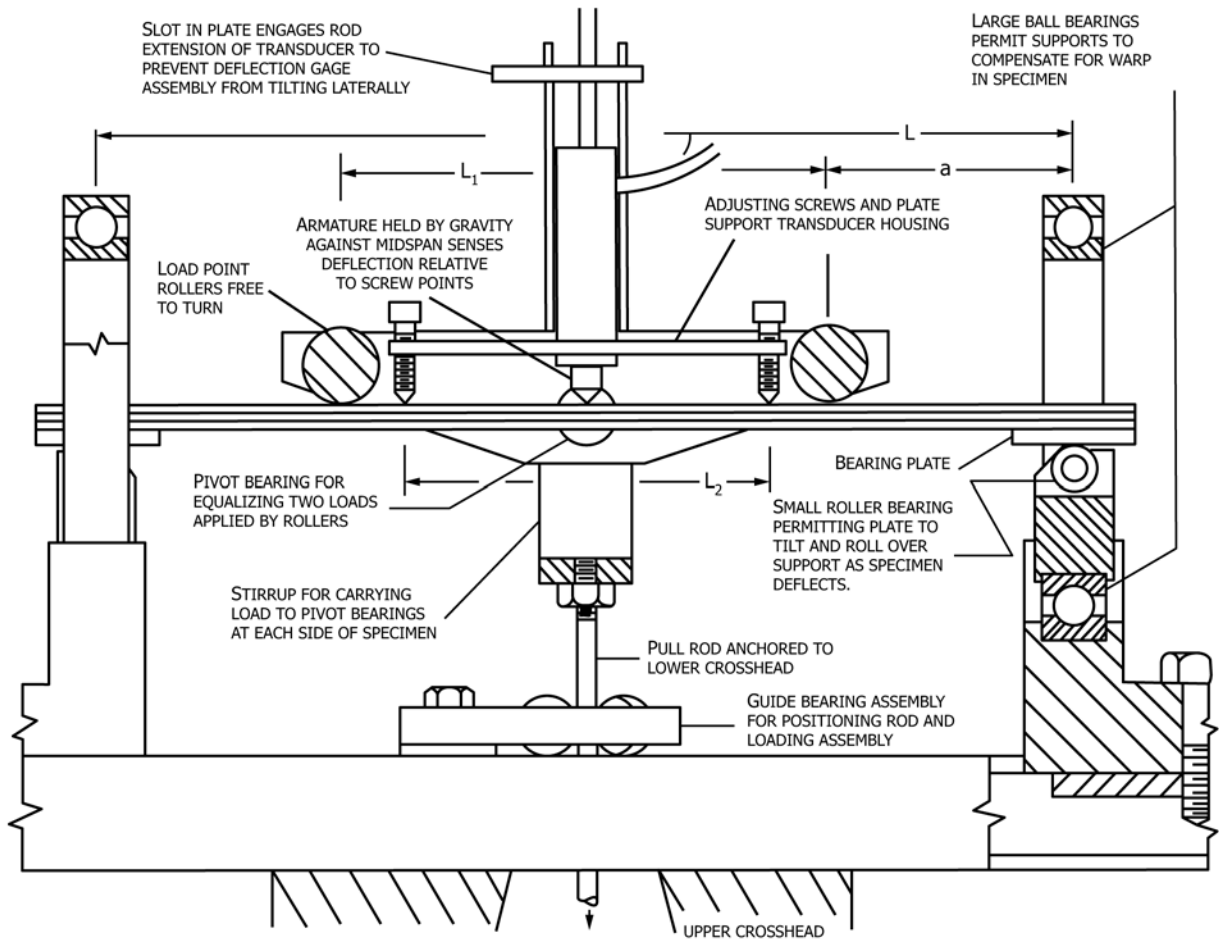

FIG. 6 Two-Point Load Test (Method B)

where:

- N = rate of motion, in./min (mm/min),
- z = unit rate of fiber strain, in./in.·min (mm/mm·min) = 0.0015,
- a = distance from support to adjacent load, in. (mm),
- d = depth of beam, in. (mm), and
- L = span, in. (mm).

6.6.1 Measure the elapsed time from initiation of loading to maximum load and record to the nearest ½ min.

6.7 *Measurement of Deflection*—Measure deflection of mid-span with respect to a line between two points equidistant from mid-span and just inside the two load points to an accuracy of at least 1½ % of total deflection if tested for stiffness only, or 1½ % of deflection at approximate proportional limit. All three points shall lie on the longitudinal axis of the specimen. Suitable equipment of the transducer type is illustrated in Fig. 6 and shown in Fig. 3. A dial gage could replace the transducer for manual reading. If individual gage readings are taken, at least 12 and preferably 15 or more load and deflection readings shall be taken below approximate proportional limit or for determining specimen stiffness.

6.8 *Calculations:*

6.8.1 Calculate the specimen bending stiffness as follows:

$$EI = [(L - L_1)L_2^2 / 32](P'/\Delta) \quad (5)$$

where:

- L_1 = span between load points, in. (mm)
- L_2 = span between deflection measurement points, in. (mm),
- P'/Δ = slope of load deflection curve where deflection is mid-span relative to ends of span L_2 , in. (mm), and other notation is as given in 5.8.1. Remarks of 5.8.2 apply.

6.8.2 Calculate maximum moment of the specimen as follows:

$$S_b I/c = P(L - L_1)/4 \quad (6)$$

where:

- P = maximum load, lbf (N),

7. Method C—Pure Moment Test

7.1 *Summary*—A specially designed testing machine applies pure moments to opposite ends of the test panel through loading frames. Frames are free to move toward or away from each other during the test to preclude application of other than pure moments to the center span of the panel. Between loading frames deflection of the neutral axis follows a circular arc. Rotational deformation between points near the ends of the arc is measured during the test by special sensing gages resting on pins projecting from the face of the panel at these points. The

test is simple and flexible, and results are directly relatable to basic properties at large deformations.

7.2 *Test Specimen*—Specimens shall be of a size comparable to that of the material in use, frequently consisting of the entire panel. Limitation on size may be imposed by equipment size or moment capacity or size of available material. Except for effects of nonuniformity of properties within a panel, specimen dimensions do not tend to influence test results. When nonuniform material containing density variation, knots, knot-holes, sloping grain or other sources of large variability is tested for general construction and industrial use, a minimum specimen width of 24 in. (610 mm) is recommended and in no case shall width be less than 12 in. (300 mm).

7.2.1 *Measurements*—Measure panel thickness at four points, two on each edge one fourth of panel length from each end, to the nearest 0.001 in. (0.02 mm) and record the average. Measure width to the nearest 0.3 % at two points one fourth of panel length from each end and record the average.

7.2.1.1 When needed for interpretation of test results for plywood, veneer composites, and laminates measure thickness of each layer to the nearest 0.001 in. (0.02 mm) at the same points at which total panel thickness is measured.

7.3 *Application and Measurement of Moments*—Fig. 7 illustrates application of pure moments to a specimen, by means of loading frames, and measurement of deformation. Apply equal and opposite pure moments to each end of the panel by frames. The frames shall be free to move toward or away from each other while under load to preclude application of direct tension or compression loads at large panel deformations. Support axes of the loading frames to remain in a parallel relationship throughout the test (Note 4). Space bars of the loading frames sufficiently to prevent shear failures between points of load application. A bar spacing of 20 times panel thickness is suggested to preclude most, if not all, shear failures in the plane of the panel. In some cases closer spacing may be entirely satisfactory.

NOTE 4—These requirements dictate use of specialized equipment which may not be readily available. The principle of a commercially available flexure testing machine complying with these requirements is

diagrammed in the figure below. Until further innovations are made in pure bending test equipment, use of cable and pulley equipment of this type, either purchased or constructed at the laboratory, offers the only practical means of implementing this method. This equipment is the subject of U.S. Patent No. 3,286,516.

7.3.1 Measure or record moment applied to either or both loading frames, either directly or in terms of a value related to moment, to an accuracy of $\pm 2\%$ of indicated value or 0.8 % of full-scale reading below 40 % of full-scale value (Note 5). Friction forces that tend to resist motion of the axes of the loading frames during a test may also cause significant errors. Therefore, when panels 4 ft in width are to be tested, the horizontal force applied to one loading frame that is required to produce motion of both frames without a panel in the machine should not exceed 5 lb (2.3 kg). Where a cable and pulley system is employed, the use of cables of the smallest possible size consistent with loads, and relatively large pulleys will help minimize friction forces.

NOTE 5—These limits are liberal in relation to conventional equipment in order to allow for laboratory fabrication and inexperience in the design of precision pure moment machines. Carefully controlled investigations may require specification or construction of more precise equipment.

7.4 *Speed of Testing*—Rotation of load frames with respect to each other shall take place at a constant rate throughout the test within $\pm 25\%$ of the rotation rate calculated as follows:

$$R = (2z/3d) (3D - 4S) \quad (7)$$

where:

- R = rotation speed between loading frames, rad/min,
- S = load frame bar spacing between points of contact with panel, in. (mm),
- D = span between outer loading frame bars, in. (mm),
- d = panel thickness, in. (mm), and
- z = strain rate for outer fiber, in./in.·min (mm/mm·min),

For structural panels the rate of outer fiber strain, z, shall be taken as 0.0015 in./in.·min (mm/mm·min).

7.4.1 Measure the elapsed time from initiation of loading to maximum load and record to the nearest 1/2 min.

7.5 *Measurement of Panel Curvature*—Measure panel curvatures between two points on the longitudinal axis of the

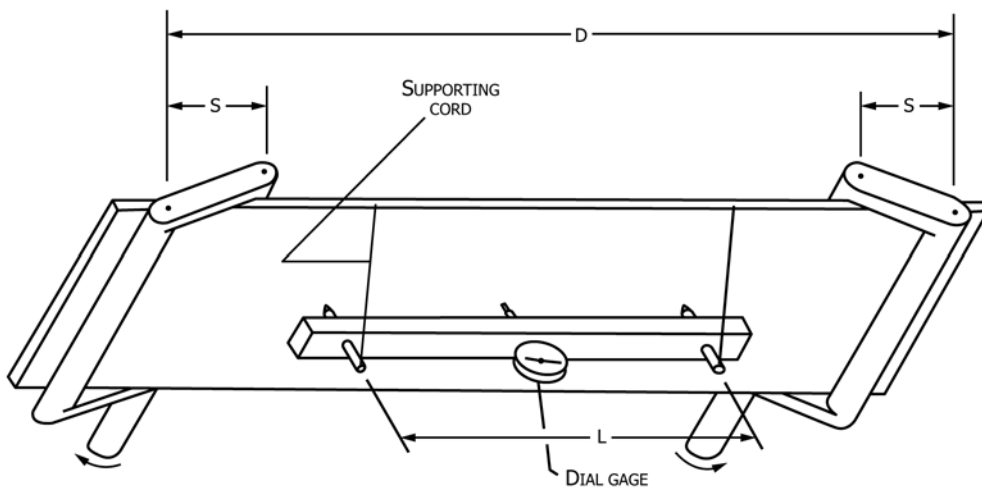

FIG. 7 Use of a Dial Gage to Measure Midordinate Deflection in a Pure Moment Bending Test (Method C)

panel located between the inner loading bars and spaced as far apart as possible consistent with maintaining adequate clearances between gages and loading bars. Take curvature data to an accuracy of at least 1½ % of proportional limit values. If gages are read, take at least 12 and preferably 15 or more readings below the approximate proportional limit. If data are automatically recorded, magnifications shall be such as to produce pen motions of at least 2½ in. (64 mm) or ¼ of full scale, whichever is larger on the axes below the proportional limit.

7.5.1 Where equipment permits changing ranges during test, recording a more highly magnified portion of the curvature data at low moments to produce full scale pen motion on at least one axis provides more accurate data for the computation of bending stiffness. The characteristically violent failures of large panels will normally dictate removal of delicate measuring instruments from the panel when sufficient data in the elastic range has been obtained.

7.5.2 Provision is made for two acceptable methods for obtaining curvature data. The midordinate deflection method employs readily available equipment to measure curvature. The angular rotation method uses special angular rotation measuring instruments to determine rotational deformation of the portion of the panel subjected to pure bending.

7.5.3 *Measurement of Panel Curvature by Midordinate*—Apparatus to determine panel curvature measures panel midordinate or deflection relative to two points as shown in Fig. 7. Reading of the dial gage to the nearest 0.001 in. (0.02 mm) normally will give ample precision. An electronic trans-

ducer could be substituted for the dial gage for direct recording if system accuracy is adequate.

7.5.4 *Measurement of Panel Curvature by Angular Rotation*—Fig. 8 illustrates a suitable method of measuring angular rotations in conjunction with electronic indicating and recording equipment. One-eighth-inch (three-millimetre) pins project perpendicularly from the face of the panel held in a vertical position by the loading frames. These pins, threaded at one end and having a small rectangular flange, are attached to the panel either by screwing them into small holes in the face of the panel until the flange is drawn tightly against the face or by inserting the pin through a hole in the panel and drawing the flange tight by means of a nut on the opposite side of the panel. A reference rod approximately the same length as the spacing between pins is fitted at each end with an angular sensing device. Each gage housing is provided with small ball bearings which permit free movement of the angular sensing gage along the rod while holding it in fixed angular relationship to it. The input shaft of each rotation gage is fitted with a flange and small V-blocks which rest on the pins projecting from the panel at each gage point, thus transmitting the angular rotation of the panel to the gage and supporting the rotation gage-reference rod assembly.

7.5.4.1 The rotation between the two gage points during test is the sum of the two rotations measured at each end of the reference rod. Use of linear differential transformers as transducers permits primaries and secondaries to be wired to produce a single signal proportional to their sum for indication or recording.

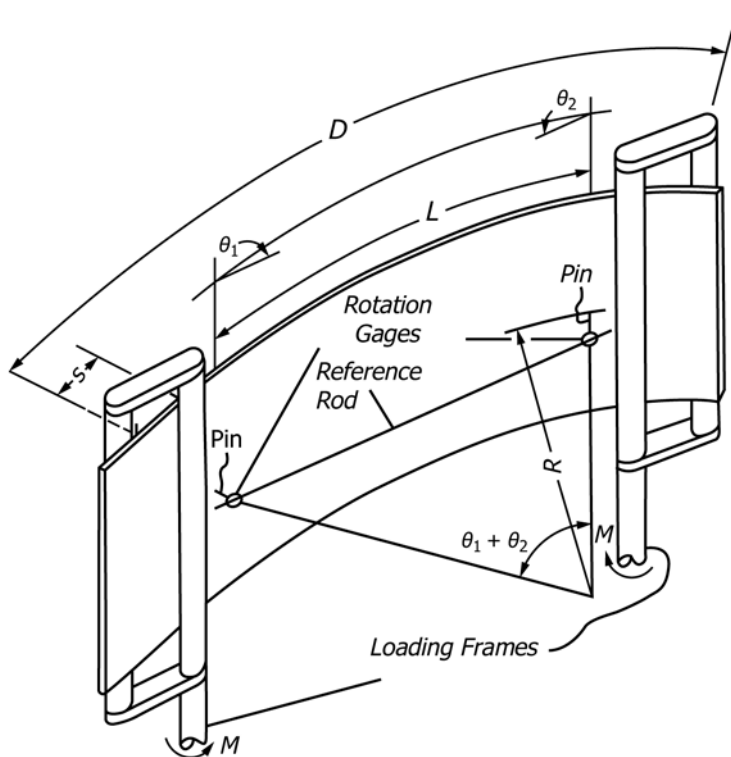

FIG. 8 Pure Bending Test Showing Angular Rotation Gages and Loading Frames

7.6 Calculations:

7.6.1 Calculate panel stiffness (EI), depending upon the method of curvature measurement, from test data in accordance with one of the following equations:

7.6.1.1 *Midordinate Method*—Determine panel bending stiffness, EI , from applied bending moment, M , and panel curvature, R , as follows:

$$EI = MR \quad (8)$$

where:

EI = panel bending stiffness, lb·in.² (N·mm²),
 M = bending moment, lbf·in. (N·mm), and
 R = panel radius of curvature, in. (mm).

Calculate the radius of curvature by the method discussed in 7.5.3 as follows:

$$R = (L^2/8\Delta) + (\Delta/2) \quad (9)$$

where:

R = radius of curvature, in. (mm),
 L = chord length for measuring midordinate or deflection, in. (mm), and
 Δ = midordinate or deflection, in. (mm).

7.6.1.2 Angular Rotation Method:

$$EI = ML/(\theta_1 + \theta_2) \quad (10)$$

where:

EI = panel bending stiffness, lbf·in.² (N·mm²) (see 5.8.2),
 M = maximum moment, lbf·in. (N·mm) (see 5.8.1.1),
 L = distance between gage points, in. (mm), and
 $\theta_1 + \theta_2$ = total angular rotation between gage points.

7.6.2 Calculate as follows:

$$S_b I/c = \text{maximum moment, lbf·in. (N·mm)} \quad (11)$$

8. Method D—Flexure Test for Quality Assurance

8.1 *Summary*—A conventional compression testing machine is used to apply and measure a load at mid-span of a small flexure specimen. Resulting deflection at mid span is measured. The test proceeds at a constant rate of loading until either sufficient deflection readings are recorded or until failure occurs, depending upon purpose.

8.2 *Test Specimen*—The test specimen shall be rectangular in cross section. The depth of the specimen shall be the thickness of the panel. The width shall be at least 3 in. (76 mm) and not wider than 4.5 in. (114 mm). The length shall be 2 in. (51 mm) plus 24 times the thickness (see Note 6). The length, width and thickness shall be measured within an accuracy of 0.3 %.

NOTE 6—In cutting the specimen to meet the length requirement, it is not intended that the length be changed for small deviations in thickness. Rather it is intended that the nominal thickness be used for determining the specimen length and span.

8.3 *Span and Supports*—The span shall be 24 times the nominal thickness (depth) of the specimen (see Note 6). The supports shall be such that no appreciable crushing of the specimen will occur at these points during the test. The supports shall be rounded or shall be knife edges provided with

rollers and plates under the specimen at these points. When rounded supports are used, the radius shall be at least 1.5 times the thickness of the material being tested. If the material under test deviates from a plane, laterally adjustable supports shall be provided (see Figs. 1 and 2).

8.4 *Center Loading Block*—The test shall use a loading block having a radius of not less than 1.5 times the specimen thickness for a chord length of at least twice the specimen thickness. The width of the loading block shall exceed the width of test specimens.

8.5 *Loading Procedure*—Apply the load continuously at a uniform rate. In accordance with Test Method D4761, the test rate shall be such that the sample target failure load would be achieved in approximately 1 min (Note 7). The failure load should not be reached in less than 10 s nor more than 10 min (Note 8).

NOTE 7—A test rate to achieve the average failure load for the sample in approximately 1 min will differ from that to achieve a lower percentile load for the same sample in approximately 1 min.

NOTE 8—For oriented strand board, the following equation provides loading rates within these guidelines:

$$N = z L^2/6d \quad (12)$$

where:

N = rate of motion, in./min (mm/min),
 L = span, in. (mm),
 d = depth of beam, in. (mm), and
 z = unit rate of fiber strain, in./in. (mm/mm) per minute of outer fiber length (0.0075).

Based on Eq 12, the loading rate is:

For 3/8 in. panel	0.27 in./min (6.9 mm/min)
For 7/16 in. panel	0.31 in./min (7.9 mm/min)
For 1/2 in. panel	0.36 in./min (9.1 mm/min)
For 5/8 in. panel	0.45 in./min (11.4 mm/min)
For in. panel	0.54 in./min (13.7 mm/min)

8.6 *Measurement of Deflection*—Take load and deflection data to determine the modulus of elasticity. Take deflection readings to the nearest 0.001 in. (0.025 mm). Choose increments of load so that not less than 12 readings and preferably more than 15 readings are taken prior to the proportional limit.

8.7 Calculations and Report:

8.7.1 Calculate bending stiffness as follows:

$$EI = (L^3/48) (P/\Delta) \quad (13)$$

where:

EI = stiffness (modulus of elasticity, psi (MPa) times moment of inertia, in.⁴ (mm⁴)),
 L = span, in. (mm), and
 P/Δ = slope of load–deflection curve, lbf/in. (N/mm).

8.7.1.1 Moment of inertia may be calculated in several different ways depending upon the purpose of the test. It may be based on the entire cross section, only the layers parallel to the span or may include all layers weighted in proportion to the modulus of elasticity in the direction parallel to span. State clearly the method employed in the report if modulus of elasticity is included.

8.7.2 Calculate the maximum moment by the following equation:

$$S_b I/c = PL/4 \quad (14)$$

where:

- $S_b I/c$ = maximum moment, lbf-in. (N-mm),
 S_b = modulus of rupture, psi (Mpa),
 P = maximum load, lbf (N), and
 c = distance from neutral axis to extreme fiber, in. (mm).

9. Variables Influencing Flexure

9.1 *Moisture Content*—Cut a moisture content sample having minimum area of 2 in.² (13 cm²) from the clear areas of the panel and weigh immediately after each test. Moisture content samples from large specimens of Method C shall have minimum area of 8 in.² (52 cm²). If inspection of the edges of panels containing veneer reveals the presence of a knot in any of the inner plies, select a second specimen. Moisture content specimens also serving as specific gravity specimens shall be free of density variations and inner ply voids such as knotholes or edge gaps between veneers. Moisture content determinations shall be made in accordance with Test Methods [D4442](#).

9.2 *Specific Gravity*—Specific gravity determinations shall be made in accordance with Test Methods [D2395](#). The specimen may be the same as that for moisture content determination but must have volume of at least 1 in.³ (16 cm³) if from small specimens and at least 3 in.³ (49 cm³) if from large specimens. Specimens with veneer shall be free of visible knots or voids.

10. Report

10.1 Each specimen shall be described as to size, species, construction, and adhesive type used in its manufacture, and principal direction of the plies, laminations, strands, or wafers with respect to specimen length.

10.2 Data for individual specimens and where applicable specimen averages shall include:

- 10.2.1 Thickness,
- 10.2.2 Specific gravity,
- 10.2.3 Moisture content,
- 10.2.4 Elapsed time to failure,
- 10.2.5 Bending stiffness,
- 10.2.6 Maximum moment,
- 10.2.7 Load-deflection diagrams, and
- 10.2.8 Description of failure.

10.3 It may also be desirable to include additional data that may influence results such as modulus of elasticity, modulus of rupture, section modulus, moment of inertia, thickness of individual plies or laminations, maximum load or moment, and natural and manufacturing features present relating to panel grade or thought to influence test results.

10.4 The method of calculating moment of inertia and section modulus shall be clearly stated. A description of the test method shall include equipment used to apply loads or moments to the panel, their points of application, deformation measuring equipment, and geometry of deformation measured.

11. Precision

11.1 The precision of these methods has not yet been determined, but when data are available precision statements will be included.

12. Keywords

- 12.1 flexural properties; panels; structural panels

APPENDIX

(Nonmandatory Information)

X1. CALCULATION OF TRUE MOMENT IN CENTER-POINT AND TWO-POINT LOAD TESTS

X1.1 The equation for calculation of true bending moment is given in [Fig. X1.1](#) for the center-point test and in [Fig. X1.2](#) for the two-point test. The errors incurred by using nominal moment instead of true moment for the computation of modulus of rupture (equations in this standard use nominal moment) depend upon the geometry of the specimen and loading at failure.

X1.2 In the case of the two-point test, measurement of the additional tangent angles and deflections during the test to

permit calculation of true moment multiplies the task of running the test and reducing the data by an order of magnitude. An approach that reduces the errors, possibly to acceptable limits for many purposes, is to develop a correction to be applied to nominal moment which varies with mid-span deflection.

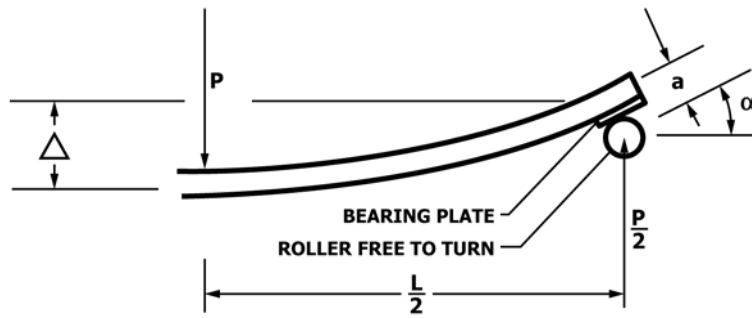

When deflection is measured relative to reactions:

$$M = (PL/4) + [(\Delta - a)(P/2)]\tan\alpha$$

where:

- M = moment at mid span, in.-lb,
- P = load, lb,
- L = span, in.,
- a = distance from center of reaction pivot to neutral axis of specimen, in.,
- α = slope of specimen at reaction, and
- Δ = deflection at mid-span relative to reactions, in.

When deflection is measured relative to two points on the neutral axis of the panel:

$$M = (PL/4) + (P\Delta/2)\tan\alpha - (Pa/2)\sin\alpha$$

where:

Δ = deflection at mid-span relative to points on the neutral axis of the panel at the reactions; other notation is as given above.

FIG. X1.1 True Moment Calculation in Center-Point Load Test

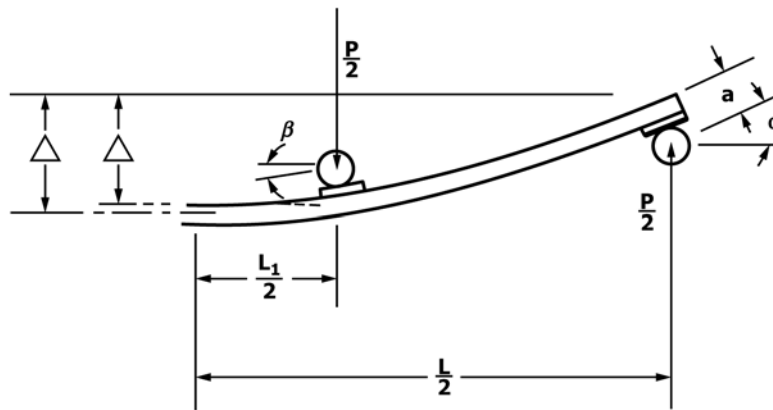

When deflection is measured relative to reactions:

$$M = (PL/4) + [(\Delta - a)(P/2)]\tan\alpha - (PL_1/4) - [(\Delta - \Delta_1 + a)(P/2)]\tan\beta$$

where:

- M = moment between load points, in.-lbf,
- P = total load, lbf,
- L = reaction span, in.,
- L_1 = load point span, in.,
- Δ = mid-span deflection relative to reactions, in.,
- Δ_1 = load point deflection relative to reactions, in.,
- a = distance from center of reaction pivot to neutral axis of specimen, in.,
- α = slope at reaction, and
- β = slope at load point.

When deflection is measured relative to two points on the neutral axis of the panel:

$$M = [P(L - L_1)/4] + (P\Delta/2)\tan\alpha - [(P/2)(\Delta - \Delta_1)]\tan\beta - (Pa/2)(\sin\alpha + \sin\beta)$$

where:

- Δ = deflection at mid-span relative to points on the neutral axis of the panel at the reactions, and
- Δ_1 = load point deflection relative to points on the neutral axis of the panel at the reactions, and other notation is as given above.

FIG. X1.2 True Moment Calculation in Two-Point Load Test

 **D3043 – 00 (2011)**

ASTM International takes no position respecting the validity of any patent rights asserted in connection with any item mentioned in this standard. Users of this standard are expressly advised that determination of the validity of any such patent rights, and the risk of infringement of such rights, are entirely their own responsibility.

This standard is subject to revision at any time by the responsible technical committee and must be reviewed every five years and if not revised, either reapproved or withdrawn. Your comments are invited either for revision of this standard or for additional standards and should be addressed to ASTM International Headquarters. Your comments will receive careful consideration at a meeting of the responsible technical committee, which you may attend. If you feel that your comments have not received a fair hearing you should make your views known to the ASTM Committee on Standards, at the address shown below.

This standard is copyrighted by ASTM International, 100 Barr Harbor Drive, PO Box C700, West Conshohocken, PA 19428-2959, United States. Individual reprints (single or multiple copies) of this standard may be obtained by contacting ASTM at the above address or at 610-832-9585 (phone), 610-832-9555 (fax), or service@astm.org (e-mail); or through the ASTM website (www.astm.org). Permission rights to photocopy the standard may also be secured from the Copyright Clearance Center, 222 Rosewood Drive, Danvers, MA 01923, Tel: (978) 646-2600; <http://www.copyright.com/>