



Standard Test Method for Cubic Foot Weight of Crushed Bituminous Coal¹

This standard is issued under the fixed designation D291; the number immediately following the designation indicates the year of original adoption or, in the case of revision, the year of last revision. A number in parentheses indicates the year of last reapproval. A superscript epsilon (ϵ) indicates an editorial change since the last revision or reapproval.

1. Scope

1.1 This test method covers two procedures for determining the cubic foot weight of crushed coal less than 1½ in. (37 mm) in size, such as is charged into coke ovens, as follows:

1.1.1 *Procedure A*—The cone procedure for determining an uncompacted weight per cubic foot (cubic metre).

1.1.2 *Procedure B*—The dropped-coal procedure for determining a compacted weight per cubic foot (cubic metre), comparable to actual bulk densities attained in coke ovens.

1.2 This test method is not applicable to the testing of powdered coal as used in boiler plants, nor to the determination of weights per cubic foot of coal in storage piles.

1.3 The values stated in inch-pound units are to be regarded as standard. The values given in parentheses are mathematical conversions to SI units that are provided for information only and are not considered standard. Mass may be expressed in metric values.

1.4 *This standard does not purport to address all of the safety concerns, if any, associated with its use. It is the responsibility of the user of this standard to establish appropriate safety and health practices and determine the applicability of regulatory limitations prior to use.*

2. Referenced Documents

2.1 ASTM Standards:²

D440 Test Method of Drop Shatter Test for Coal

D2234/D2234M Practice for Collection of a Gross Sample of Coal

D3038 Test Method for Drop Shatter Test for Coke

D3302 Test Method for Total Moisture in Coal

D4749 Test Method for Performing the Sieve Analysis of Coal and Designating Coal Size

¹ This test method is under the jurisdiction of ASTM Committee D05 on Coal and Coke and is the direct responsibility of Subcommittee D05.15 on Metallurgical Properties of Coal and Coke.

Current edition approved Sept. 1, 2012. Published October 2007. Originally approved in 1927. Last previous edition approved in 2007 as D291 – 07^{ε1}. DOI: 10.1520/D0291-07R12.

² For referenced ASTM standards, visit the ASTM website, www.astm.org, or contact ASTM Customer Service at service@astm.org. For *Annual Book of ASTM Standards* volume information, refer to the standard's Document Summary page on the ASTM website.

3. Significance and Use

3.1 This test method concerns the compaction of crushed coal to determine either its compacted or uncompacted weight, for purposes such as charging coke ovens.

PROCEDURE A—CONE PROCEDURE FOR UNCOMPACTED CUBIC FOOT (CUBIC METRE) WEIGHT

4. Apparatus

4.1 *Measuring Box*, of rigid construction, having inside dimensions of 12.0 by 12.0 by 12.0 in. (305 by 305 by 305 mm), and a volume of $1728 \pm 5 \text{ in.}^3$ ($0.0283 \text{ m}^3 \pm 82 \text{ cm}^3$). The exact volume of the box shall be determined by water calibration.

4.2 *Cone*, conforming to Fig. 1 for filling the box. This cone shall be 2 ft 0 in. (610 mm) high and 1 ft 8 in. (508 mm) in inside diameter at the top, with a circular opening 4½ in. (114 mm) in diameter at the bottom. A slide valve consisting of a sliding-plate shutter and its supports shall be welded to the bottom of the cone in such a manner that the valve may be opened and closed with ease by removing or inserting the shutter in its supporting slides. The cone shall be supported in a tripod frame having a circular opening at the top of about 1 ft 6 in. (457 mm) in diameter. This frame shall support the cone so that the top-side of the shutter shall be 1 ft 10 in. (559 mm) from the inside bottom surface of the box. (See Fig. 1.)

4.3 *Leveling Bar*, a steel strip 2 ft 6 in. long by 1½ in. wide (762 by 38 mm) and approximately $\frac{3}{16}$ in. (5 mm) thick.

4.4 *Scales*, platform, capable of weighing up to 200 lb (100 kg) and sensitive to 0.1 lb (0.05 kg).

5. Sampling

5.1 *Gross Sample*—For collecting gross samples of crushed bituminous coal, the procedure described in Sections 7 and 8 of Practice D2234/D2234M shall apply. During the period of collecting the gross sample, the increments of the sample shall be stored in a waterproof container with a tightly fitting cover in order to prevent the loss of moisture. The minimum number and weights of increments collected shall be in accordance with Table 2 of Practice D2234/D2234M. The minimum gross weight of the sample shall be 300 lb (136 kg).

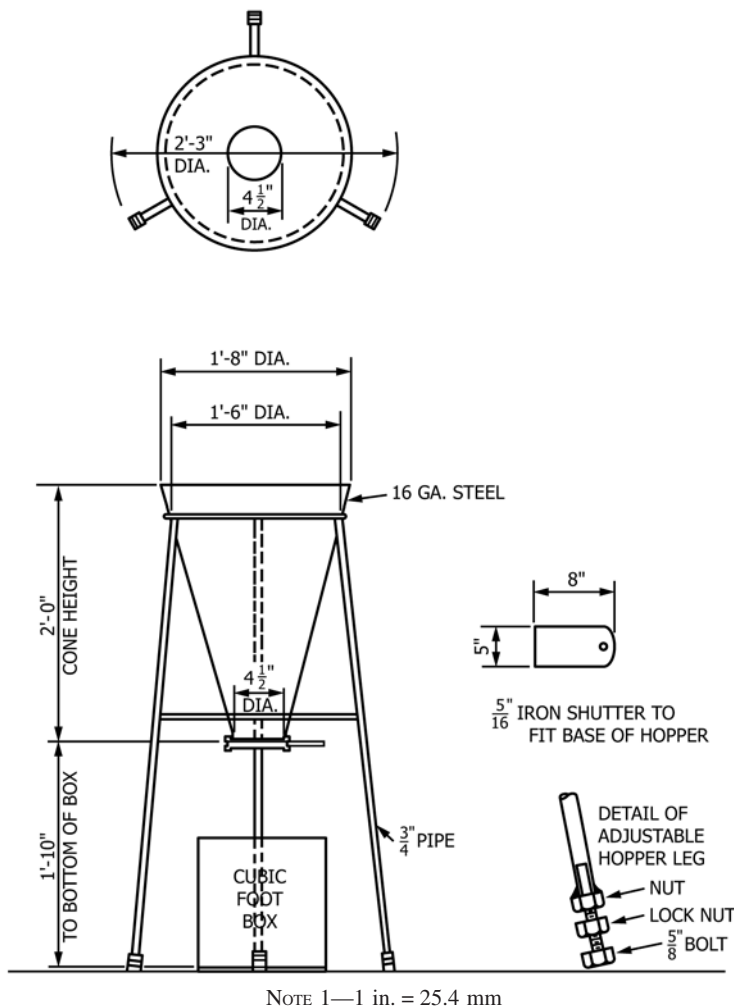

NOTE 1—1 in. = 25.4 mm
FIG. 1 Apparatus for Cone Procedure

5.2 *Laboratory Sample*—The gross sample of coal shall be thoroughly mixed and subdivided, without crushing, into four 75-lb (34-kg) portions. This operation shall be done as quickly as possible to avoid loss of moisture, and the cubic foot (cubic metre) weight shall be determined immediately. If this determination cannot be made immediately, the samples shall be kept in waterproof containers with tightly fitting covers until the time for making the determination.

6. Procedure

6.1 Before filling the cone hopper, level it in its tripod on a solid floor. Pour the prepared sample into a pile on the floor and carefully flatten it to about 4 in. (100 mm) in thickness. Avoid pounding of the pile with the back of the shovel. Take successive shovelfuls from uniformly distributed points in the pile, and allow them to slide gently from the shovel into the hopper at different peripheral points. This will prevent segregation and packing while the hopper is being filled. Place about 75 lb (34 kg) of coal in the hopper.

6.2 Center the previously weighed cubic foot (cubic metre) box under the valve of the cone. Then remove the valve shutter completely, allowing all of the coal to flow into the box and overflow the edges. Loosen wet coal, not flowing freely from

the hopper, by gently thrusting downward through the coal to the valve with the leveling bar.

6.3 After filling the box, carefully level off the excess coal above the box edge by means of the leveling bar, and place the box on the platform scale and weigh it to the nearest 0.1 lb (0.05 kg). Avoid jarring or shifting of the filled box until all excess coal is leveled off. Record the difference in weight between the filled and empty box to the nearest 0.1 lb (0.05 kg) as the uncompacted cubic foot weight.

NOTE 1—Aside from the character of the coal itself, moisture content and size distribution of the coal are the two main factors which affect the cubic foot weight. A moisture determination and sieve analysis of the coal should be reported along with the cubic foot weight for proper interpretation of the cubic foot weight. For directions for making these determinations, see the following:

- Moisture*—Test Method [D3302](#).
- Sieve Analysis*—Method [D4749](#).

7. Precision and Bias

7.1 *Repeatability:*

7.1.1 Duplicate results by the same operator in a given laboratory on consecutive tests determined within a minimum interval of time shall be considered suspect if they differ by more than 0.6 lb/ft³ (9.6 kg/m³).

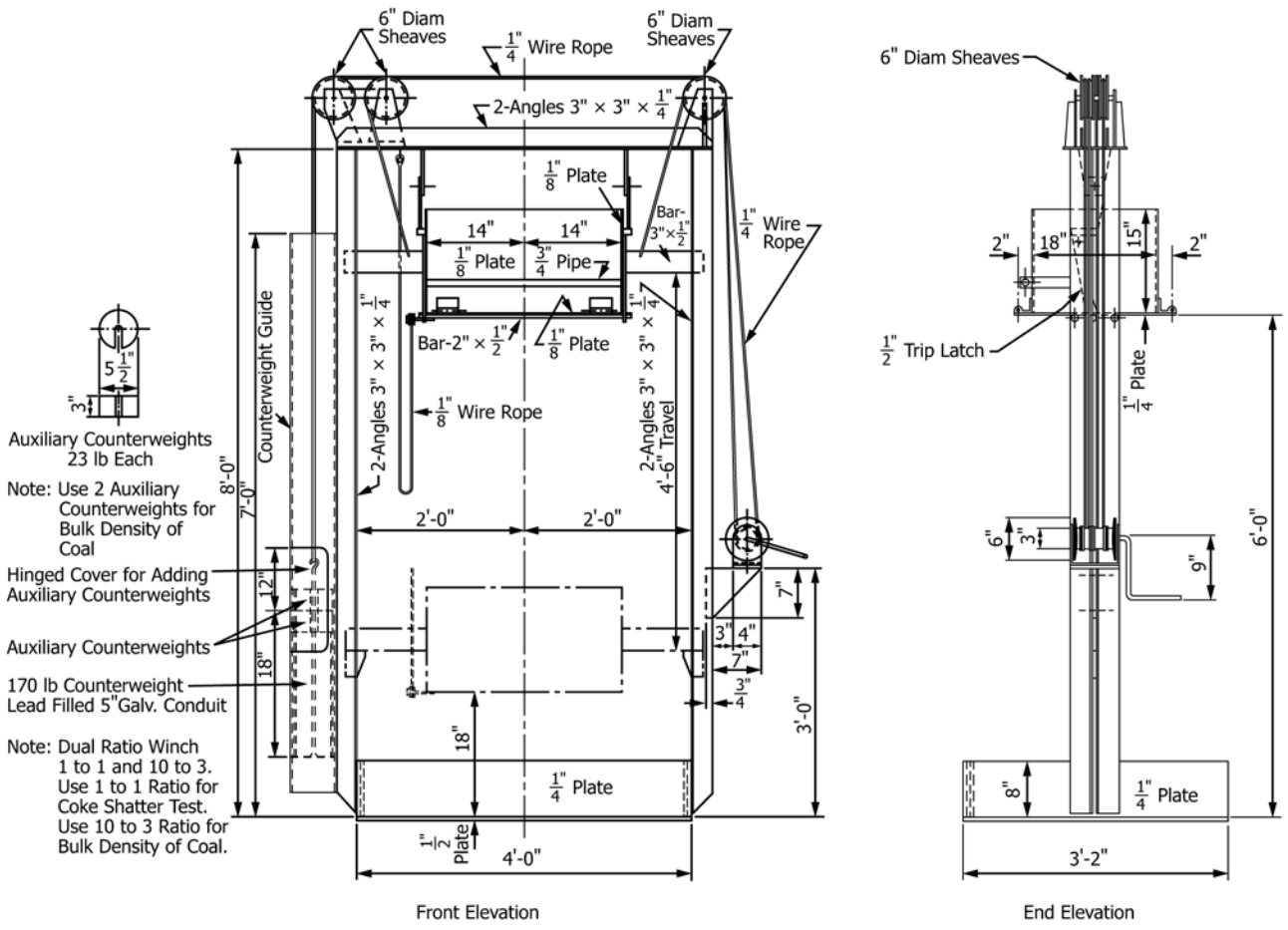

NOTE 1—1 in. = 25.4 mm

1 lb = 0.4359 kg

FIG. 2 Apparatus for Dropped Coal Procedure

7.1.2 When two results are obtained that differ by more than this value, two additional tests shall be made. If the second pair of results differs by less than the repeatability, the first pair shall be discarded and the mean of the second pair shall be reported as the result of the test.

7.1.3 When both pairs of results exceed the repeatability, the mean of the four results shall be reported, provided that the two most divergent results differ by less than 0.8 lb/ft³ (1.3 kg/m³). Otherwise, all results shall be discarded and the apparatus, procedure, and sample shall be examined for noncompliance causes, which should be corrected before redetermining new pairs of values.

7.2 *Reproducibility*—The reproducibility of this test method is not known. The subcommittee is investigating the reproducibility of this test method.

7.3 *Bias*—This is an empirical method and no statement of bias is possible.

PROCEDURE B—DROPPED-COAL PROCEDURE FOR COMPACTED CUBIC FOOT (CUBIC METRE) WEIGHT³

8. Apparatus

8.1 *Measuring Box*, specially constructed, externally braced to ensure rigidity, having inside dimensions of 18.0 by 24.0 by 8.0 in. (457 by 610 by 203 mm) high, and a volume of 3456 ± 10 in.³ (0.0566 m³ ± 164 cm³). The exact volume of the box shall be determined by water calibration.

8.2 *Dropping Apparatus*, consisting of the shatter test machine described and illustrated in Test Method D3038 and Test Method D440. It shall consist of a box 18 in. in width, 28 in.

³ Auvi, H. S., Schmidt, L. D., and Graham, H. G., "Control of Bulk Densities in Coke Ovens: Studies on Precision and Application of Various Testing Methods," U. S. Bureau of Mines R.I. 3935 (1946).

in length, and approximately 15 in. in depth (0.46 by 0.71 by 0.38 m), supported above a rigidly mounted cast iron or steel plate, not less than ½ in. (13 mm) in thickness, 38 in. in width, and 48 in. (0.97 by 1.22 m) in length. The inside of the bottom of the box shall be 6 ft (1.83 m) above the plate. The bottom of the box shall consist of two doors hinged lengthwise and latched so that they will swing open freely and not impede the fall of the coal. In order to facilitate filling the box with coal, the box shall be constructed so that it can be lowered to a convenient level. This is best done by means of the arrangement shown in Fig. 2.

8.3 *Leveling Bar*, steel strip 2 ft 6 in. long by 1½ in. wide and approximately ⅜ in. (762 by 38 by 5 mm) thick.

8.4 *Scales*, platform, capable of weighing up to 200 lb (100 kg) and sensitive to 0.1 lb (0.05 kg).

9. Sampling

9.1 *Gross Sample*—For collecting gross samples of crushed bituminous coal, the procedure described in Sections 7 and 8 of Practice D2234/D2234M shall apply. During the period of collecting the gross sample, the increments of the sample shall be stored in a waterproof container with a tightly fitting cover in order to prevent the loss of moisture. The minimum number and weights of increments collected shall be in accordance with Table 2 of Practice D2234/D2234M. The minimum gross weight of sample shall be 800 lb (360 kg).

9.2 *Laboratory Sample*—The gross sample of coal shall be thoroughly mixed and subdivided, without crushing, into four 200-lb (90 kg) portions. This operation shall be done as quickly as possible to avoid loss of moisture, and the cubic foot (cubic metre) weight shall be determined immediately. If this determination cannot be made immediately, the samples shall be kept in waterproof containers with tightly fitting covers until the time for making the determination.

10. Procedure

10.1 Place the previously weighed measuring box on the floor of the dropping apparatus and center it directly under the hopper with the long axis of the box parallel to the long axis of the hopper. Mark the floor of the dropping apparatus so that the measuring box will always be positioned exactly the same each time.

10.2 Pour the prepared coal sample into a pile on the floor and carefully flatten it to about 4 in. (100 mm) in thickness.

Avoid pounding of the pile with the back of the shovel. Take successive shovelfuls from uniformly distributed points in the pile, and carefully place them into the hopper to avoid segregation. Place each shovelful to one side of the preceding one until 180 to 200 lb (82 to 90 kg) are contained in the hopper, avoiding any heaping up of the coal at any one point as well as any compacting of the coal with the shovel.

10.3 Raise the hopper containing the coal and allow the coal to drop into the measuring box from the 6-ft (1.83-m) height. Carefully level the excess coal even with the top edge of the box by means of the leveling bar. Avoid jarring or shifting of the filled box until all excess coal is leveled. Fill any voids left in the corners of the box below the top edge by gently raking the excess coal across the corner. Place the box, or its contents, on the platform scale and weigh it to the nearest 0.1 lb (0.05 kg). Record the difference in weight between the filled and empty box to the nearest 0.1 lb (0.05 kg) as the compacted cubic foot weight (see Note under Section 6).

11. Precision and Bias

11.1 Repeatability:

11.1.1 Duplicate results by the same operator in a given laboratory on consecutive tests determined within a minimum interval of time shall be considered suspect if they differ by more than 1.0 lb/ft³ (1.60 kg/m³).

11.1.2 When two results are obtained that differ by more than this value, two additional tests shall be made. If the second pair of results differs by less than the repeatability, the first pair shall be discarded and the mean of the second pair shall be reported as the result of the test.

11.1.3 When both pairs of results exceed the repeatability, the mean of the four results shall be reported, provided that the two most divergent results differ by less than 1.3 lb/ft³ (2.1 kg/m³). Otherwise, all results shall be discarded and the apparatus, procedure, and sample shall be examined for non-compliance causes, which should be corrected before redetermining new pairs of values.

11.2 *Reproducibility*—The reproducibility of this test method is not known. The subcommittee is investigating the reproducibility of this test method.

11.3 *Bias*—This is an empirical method and no statement of bias is possible.

12. Keywords

12.1 crushed coal; cubic foot weight

ASTM International takes no position respecting the validity of any patent rights asserted in connection with any item mentioned in this standard. Users of this standard are expressly advised that determination of the validity of any such patent rights, and the risk of infringement of such rights, are entirely their own responsibility.

This standard is subject to revision at any time by the responsible technical committee and must be reviewed every five years and if not revised, either reapproved or withdrawn. Your comments are invited either for revision of this standard or for additional standards and should be addressed to ASTM International Headquarters. Your comments will receive careful consideration at a meeting of the responsible technical committee, which you may attend. If you feel that your comments have not received a fair hearing you should make your views known to the ASTM Committee on Standards, at the address shown below.

This standard is copyrighted by ASTM International, 100 Barr Harbor Drive, PO Box C700, West Conshohocken, PA 19428-2959, United States. Individual reprints (single or multiple copies) of this standard may be obtained by contacting ASTM at the above address or at 610-832-9585 (phone), 610-832-9555 (fax), or service@astm.org (e-mail); or through the ASTM website (www.astm.org). Permission rights to photocopy the standard may also be secured from the Copyright Clearance Center, 222 Rosewood Drive, Danvers, MA 01923, Tel: (978) 646-2600; http://www.copyright.com/