



Designation: D2892 – 17a

Standard Test Method for Distillation of Crude Petroleum (15-Theoretical Plate Column)¹

This standard is issued under the fixed designation D2892; the number immediately following the designation indicates the year of original adoption or, in the case of revision, the year of last revision. A number in parentheses indicates the year of last reapproval. A superscript epsilon (ϵ) indicates an editorial change since the last revision or reapproval.

1. Scope*

1.1 This test method covers the procedure for the distillation of stabilized crude petroleum (see **Note 1**) to a final cut temperature of 400 °C Atmospheric Equivalent Temperature (AET). This test method employs a fractionating column having an efficiency of 14 to 18 theoretical plates operated at a reflux ratio of 5:1. Performance criteria for the necessary equipment is specified. Some typical examples of acceptable apparatus are presented in schematic form. This test method offers a compromise between efficiency and time in order to facilitate the comparison of distillation data between laboratories.

NOTE 1—Defined as having a Reid vapor pressure less than 82.7 kPa (12 psi).

1.2 This test method details procedures for the production of a liquefied gas, distillate fractions, and residuum of standardized quality on which analytical data can be obtained, and the determination of yields of the above fractions by both mass and volume. From the preceding information, a graph of temperature versus mass % distilled can be produced. This distillation curve corresponds to a laboratory technique, which is defined at 15/5 (15 theoretical plate column, 5:1 reflux ratio) or TBP (true boiling point).

1.3 This test method can also be applied to any petroleum mixture except liquefied petroleum gases, very light naphthas, and fractions having initial boiling points above 400 °C.

1.4 This test method contains the following annexes and appendices:

1.4.1 **Annex A1**—Test Method for the Determination of the Efficiency of a Distillation Column,

1.4.2 **Annex A2**—Test Method for the Determination of the Dynamic Holdup of a Distillation Column,

1.4.3 **Annex A3**—Test Method for the Determination of the Heat Loss in a Distillation Column (Static Conditions),

¹ This test method is under the jurisdiction of ASTM Committee D02 on Petroleum Products, Liquid Fuels, and Lubricants and is the direct responsibility of Subcommittee D02.08 on Volatility.

Current edition approved July 1, 2017. Published July 2017. Originally approved in 1970. Last previous edition approved in 2017 as D2892 – 17. DOI: 10.1520/D2892-17A.

1.4.4 **Annex A4**—Test Method for the Verification of Temperature Sensor Location,

1.4.5 **Annex A5**—Test Method for Determination of the Temperature Response Time,

1.4.6 **Annex A6**—Practice for the Calibration of Sensors,

1.4.7 **Annex A7**—Test Method for the Verification of Reflux Dividing Valves,

1.4.8 **Annex A8**—Practice for Conversion of Observed Vapor Temperature to Atmospheric Equivalent Temperature (AET),

1.4.9 **Appendix X1**—Test Method for Dehydration of a Sample of Wet Crude Oil, and

1.4.10 **Appendix X2**—Practice for Performance Check.

1.5 The values stated in SI units are to be regarded as the standard.

1.5.1 **Exception**—The values given in parentheses are for information only.

1.6 *This standard does not purport to address all of the safety concerns, if any, associated with its use. It is the responsibility of the user of this standard to establish appropriate safety and health practices and determine the applicability of regulatory limitations prior to use. For specific warning statements, see Section 10.*

1.7 **WARNING**—Mercury has been designated by many regulatory agencies as a hazardous material that can cause central nervous system, kidney, and liver damage. Mercury, or its vapor, may be hazardous to health and corrosive to materials. Caution should be taken when handling mercury and mercury containing products. See the applicable product Material Safety Data Sheet (MSDS) for details and EPA's website—<http://www.epa.gov/mercury/faq.htm>—for additional information. Users should be aware that selling mercury and/or mercury containing products into your state or country may be prohibited by law.

1.8 *This international standard was developed in accordance with internationally recognized principles on standardization established in the Decision on Principles for the Development of International Standards, Guides and Recommendations issued by the World Trade Organization Technical Barriers to Trade (TBT) Committee.*

*A Summary of Changes section appears at the end of this standard

2. Referenced Documents

2.1 ASTM Standards:²

- D941** Test Method for Density and Relative Density (Specific Gravity) of Liquids by Lipkin Bicapillary Pycnometer³
- D1217** Test Method for Density and Relative Density (Specific Gravity) of Liquids by Bingham Pycnometer
- D1298** Test Method for Density, Relative Density, or API Gravity of Crude Petroleum and Liquid Petroleum Products by Hydrometer Method
- D2887** Test Method for Boiling Range Distribution of Petroleum Fractions by Gas Chromatography
- D3710** Test Method for Boiling Range Distribution of Gasoline and Gasoline Fractions by Gas Chromatography (Withdrawn 2014)⁴
- D4006** Test Method for Water in Crude Oil by Distillation
- D4052** Test Method for Density, Relative Density, and API Gravity of Liquids by Digital Density Meter
- D4057** Practice for Manual Sampling of Petroleum and Petroleum Products
- D4177** Practice for Automatic Sampling of Petroleum and Petroleum Products
- D5134** Test Method for Detailed Analysis of Petroleum Naphthas through n-Nonane by Capillary Gas Chromatography
- D6300** Practice for Determination of Precision and Bias Data for Use in Test Methods for Petroleum Products and Lubricants
- D6729** Test Method for Determination of Individual Components in Spark Ignition Engine Fuels by 100 Metre Capillary High Resolution Gas Chromatography
- D6730** Test Method for Determination of Individual Components in Spark Ignition Engine Fuels by 100-Metre Capillary (with Precolumn) High-Resolution Gas Chromatography
- D6733** Test Method for Determination of Individual Components in Spark Ignition Engine Fuels by 50-Metre Capillary High Resolution Gas Chromatography

3. Terminology

3.1 Definitions:

3.1.1 *adiabaticity, n*—the condition in which there is no significant gain or loss of heat throughout the length of the column.

3.1.1.1 *Discussion*—When distilling a mixture of compounds as is the case of crude petroleum, there will be a normal increase in reflux ratio down the column. In the case where heat losses occur in the column, the internal reflux is abnormally greater than the reflux in the head. The opposite is true when the column gains heat, as with an overheated mantle.

3.1.2 *boilup rate, n—in distillation*, the quantity of vapor entering the column per unit of time.

3.1.3 *debutanization of crude petroleum, n*—the removal of the light hydrocarbons up to and including *n*-butane, and retention of the heavier hydrocarbons.

3.1.3.1 *Discussion*—In practice, a crude petroleum is regarded as debutanized if the light hydrocarbon cut collected in the cold trap contains more than 95 % of the C₂ to C₄ hydrocarbons and less than 5 % of the C₅ hydrocarbons initially present in the sample.

3.1.4 *distillation pressure, n*—the pressure measured as close as possible to the point where the vapor temperature is taken, normally at the top of the condenser.

3.1.5 *distillation temperature, n*—the temperature of the saturated vapor measured in the head just above the fractionating column.

3.1.5.1 *Discussion*—It is also known as the head temperature or the vapor temperature.

3.1.6 *dynamic hold-up, n—in column distillation*, the quantity of liquid held up in the column under normal operating conditions.

3.1.7 *flood point, n—in distillation*, the point at which the velocity of the upflowing vapors obstructs the down-coming reflux and the column suddenly fills with liquid.

3.1.8 *internal reflux, n—in distillation*, the liquid normally running down inside the column.

3.1.9 *pressure drop, n*—the difference between the pressure measured in the condenser and the pressure measured in the distillation flask.

3.1.9.1 *Discussion*—It is expressed in kilopascals (mm Hg) per metre of packed height for packed columns, or kilopascals (mm Hg) overall for real plate columns. It is higher for aromatics than for paraffins, and for higher molecular weights than for lighter molecules, at a given boilup rate.

3.1.10 *reflux ratio, R, n—in distillation*, the ratio of the condensate at the head of the column that is returned to the column (*reflux*) to that withdrawn as product.

3.1.11 *static hold-up or wettag, n*—the quantity of liquid retained in the column after draining at the end of a distillation.

3.1.11.1 *Discussion*—It is characteristic of the packing or the design of the plates, and depends on the composition of the material in the column at the final cut point and on the final temperature.

3.1.12 *takeoff rate, n—in distillation*, the volume of product withdrawn from the reflux divider over a specified period.

3.1.13 *theoretical plate, n*—the section of a column required to achieve thermodynamic equilibrium between a liquid and its vapor.

3.1.13.1 *Discussion*—The height equivalent to one theoretical plate (HETP) for packed columns is expressed in millimetres. In the case of real plate columns, the efficiency is expressed as the percentage of one theoretical plate that is achieved on one real plate.

² For referenced ASTM standards, visit the ASTM website, www.astm.org, or contact ASTM Customer Service at service@astm.org. For *Annual Book of ASTM Standards* volume information, refer to the standard's Document Summary page on the ASTM website.

³ Withdrawn. The last approved version of this historical standard is referenced on www.astm.org.

⁴ The last approved version of this historical standard is referenced on www.astm.org.

4. Summary of Test Method

4.1 A weighed sample of 1 L to 30 L of stabilized crude petroleum is distilled to a maximum temperature of 400 °C AET in a fractionating column having an efficiency at total reflux of at least 14, but not greater than 18, theoretical plates.

4.2 A reflux ratio of 5:1 is maintained at all operating pressures, except that at the lowest operating pressures between 0.674 kPa and 0.27 kPa (5 mm and 2 mm Hg), a reflux ratio of 2:1 is optional. In cooperative testing or in cases of dispute, the stages of low pressure, the reflux ratios, and the temperatures of cut points must be mutually agreed upon by the interested parties prior to beginning the distillation.

4.3 Observations of temperature, pressure, and other variables are recorded at intervals and at the end of each cut or fraction.

4.4 The mass and density of each cut or fraction are obtained. Distillation yields by mass are calculated from the mass of all fractions, including liquefied gas cut and the residue. Distillation yields by volume of all fractions and the residue at 15 °C are calculated from mass and density.

4.5 From these data the TBP curves in mass or volume percent, or both, versus AET are drawn.

5. Significance and Use

5.1 This test method is one of a number of tests conducted on a crude oil to determine its value. It provides an estimate of the yields of fractions of various boiling ranges and is therefore valuable in technical discussions of a commercial nature.

5.2 This test method corresponds to the standard laboratory distillation efficiency referred to as 15/5. The fractions produced can be analyzed as produced or combined to produce samples for analytical studies, engineering, and product quality evaluations. The preparation and evaluation of such blends is not part of this test method.

5.3 This test method can be used as an analytical tool for examination of other petroleum mixtures with the exception of LPG, very light naphthas, and mixtures with initial boiling points above 400 °C.

6. Apparatus

6.1 *Distillation at Atmospheric Pressure*—All components must conform to the requirements specified as follows. Automatic devices can be employed provided they meet the same requirements. A typical apparatus is illustrated in [Fig. 1](#).

6.1.1 *Distillation Flask*—The distillation flask shall be of a size that is at least 50 % larger than the volume of the charge. The size of the charge, between 1.0 L and 30 L, is determined by the holdup characteristics of the fractionating column, as shown in [Table 1](#) and described in [Annex A2](#). The distillation flask shall have at least one sidearm.

6.1.1.1 The sidearm is used as a thermowell. It shall terminate about 5 mm from the bottom of the flask to ensure its immersion at the end of the distillation. When a second sidearm is present, it can be used for pressure drop detection with a nitrogen bleed or for mechanical stirring, or both.

6.1.1.2 If a magnetic stirrer is used with a spherical flask, the flask shall have a slightly flattened or concave area at the bottom on which the magnetic stirrer can rotate without grinding the glass. In this case, termination of the thermowell shall be off center 40 mm \pm 5 mm to avoid the magnetic stirring bar. Boiling chips can be used as an alternative to a stirrer.

6.1.1.3 (**Warning**—While the advantage of visibility in glass distillation flasks is desirable, flasks of glass may become hazardous the larger the charge they contain. For this reason, glass flasks of a volume greater than 10 L are not recommended.)

6.1.2 *Heating System*—Heating of the flask shall be provided in such a way that full boilup can be maintained at a steady rate at all pressure levels. An electric heating mantle covering the lower half of the flask and having one third of the heat in an element located in the bottom central area and the remaining two thirds in the rest of the hemisphere is recommended. While proportioning controllers are preferred, heat input can be manually adjusted by use of a variable auto transformer on each circuit, the smaller heater being automatically controlled by an instrument sensing the pressure drop of the column as registered in a differential pressure instrument or alternatively by direct measurement of distillation rate.

6.1.2.1 Minimum wattage required to provide full boilup of crude petroleum is approximately 0.125 W/mL of charge. Twice this amount is recommended for quick heat-up.

6.1.2.2 The heat density in the flask heaters is approximately equal to 0.5 W/cm² to 0.6 W/cm². This requires the use of nickel-reinforced quartz fabric to ensure a reasonable service life.

6.1.2.3 Immersion heaters can be employed in a similar way and have the advantage of faster response, but they are more fragile and require a specially designed flask to ensure that the heating elements remain immersed at the end of the run. When used, their heat density should be approximately equal to 4 W/cm².

6.1.2.4 The upper half of the flask shall be covered with a mantle to avoid unnecessary heat losses from the upper surface and shall have an electric heater supplying about 0.25 W/cm² at full-rated voltage.

6.1.3 *Fractionating Column*—The fractionating column must contain either particulate packing or real plates similar to those whose performance characteristics are summarized in [Table 1](#) and meet the specifications stated in [6.1.3.1](#) through [6.1.3.4](#). [Table 2](#) lists current North American suppliers of suitable packings.

6.1.3.1 The internal diameter shall be between 25 mm and 70 mm.

6.1.3.2 The efficiency shall be between 14 and 18 theoretical plates at total reflux when measured by the procedure described in [Annex A1](#).

6.1.3.3 The fractionating column shall be comprised of an integral glass column and reflux divider totally enclosed in a highly reflective vacuum jacket having a permanent vacuum of less than 0.1 mPa ($\sim 10^{-6}$ mm Hg). It shall be essentially adiabatic when tested in accordance with [Annex A3](#).

NOTE 2—In the case of an adiabatic column when distilling a pure

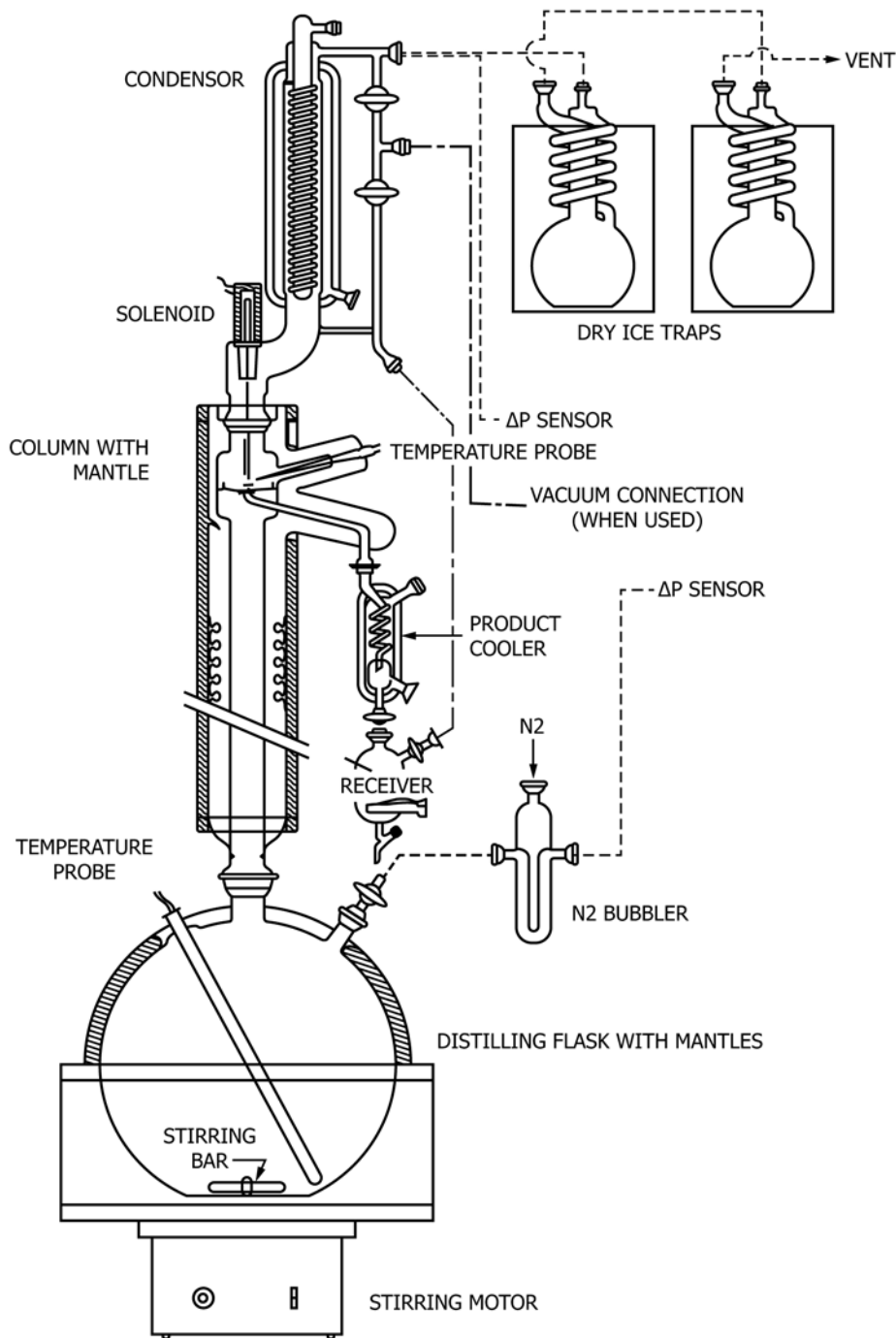

FIG. 1 Apparatus

compound, the internal reflux is constant from top to bottom and is equal to the reflux at the reflux divider. When distilling crude petroleum, the fractionation occurring in the dynamic holdup will cause a temperature gradient to be established with attendant greater amount of internal reflux at the bottom of the column.

6.1.3.4 The column shall be enclosed in a heat-insulating system, such as a glass-fabric mantle, capable of maintaining the temperature of the outer wall of the glass vacuum jacket equal to that of the internal vapor temperature. To verify this, the vacuum jacket shall have a temperature sensor, such as a thermocouple, soldered to about 6 cm² of thin copper or brass

sheet and fastened to the outer wall of the glass jacket at a level just below the reflux divider.

NOTE 3—For certain types of columns there is no significant difference in yields and fraction qualities between an uncompensated and a heat-compensated column. In such a case, by mutual agreement between parties concerned, the application of a heated insulating system can be omitted.

6.1.3.5 The adjustable reflux divider shall be located about one column diameter above the top of the packing or topmost plate. It must be capable of dividing the condensate with an

TABLE 1 Data for *n*-Heptane-Methylcyclohexane Test Mixture at 75 % of Maximum Boilup and 101.3 kPa (760 mm Hg)

	Propak ^{A,B,C,D,E}			Helipak ^{F,G,H}		Perforated Plates ^{E,I,J}		Wire Mesh ^{E,K}	
Column diameter, mm	25	50	70	25	50	25	50	25	50
Packing size, mm	4	6	6	No. 2917	No. 2918	NA ^L	NA ^L	NA ^L	NA ^L
Boilup, mL/h × cm ²	650	670	675	300	350	640	660	810	1050
Dynamic holdup									
% of packed volume	17	15.3	17.0	15	14.3	NA ^L	NA ^L	8.0	10.0
mL/theoretical plate	3.2	16	39	1.6	8.7	2.8	12.3	2.0	12.9
Pressure drop									
kPa/m	1.2	1.05	0.94	1.53	1.41	NA ^L	NA ^L	0.97	0.75
mm Hg/m	9.0	7.9	7.1	11.5	10.6	NA ^L	NA ^L	7.3	5.6
kPa/theoretical plate	0.045	0.056	0.06	0.03	0.045	0.15	0.16	0.05	0.05
mm Hg/theoretical plate	0.34	0.42	0.43	0.24	0.34	1.1	1.2	0.35	0.37
HETP, mm (% of real plates)	38	53	61	21	32	(60 %)	(65 %)	48	66
For 15-plate Towers									
Packed height, cm (plates)	57	80	91	31.5	48	(25)	(23)	72	99
Packed volume, mL	280	1570	3460	155	917	NA ^L	NA ^L	353	1940
Dynamic holdup, mL	47	240	590	23	131	42	184	28	194
Pressure drop									
kPa	0.68	0.84	0.86	0.48	0.68	2.2	2.4	0.70	0.73
mm Hg	5.1	6.3	6.5	3.6	5.1	16.5	18.0	5.3	5.5
Charge volume, L									
Min (4 % Holdup)	1.2	6.0	15	0.575	3.3	1.0	4.6	0.7	4.9
Max (1 % Holdup)	4.8	24.0	60	2.3	13.0	4.2	10.4	2.8	19.4

^A Cooke, G. M. and Jameson, B. G. *Analytical Chemistry*, Vol 27, 1955, p. 1798.

^B Struck, R. T. and Kinner, C. R. *Industrial and Engineering Chemistry*, Vol 42, 1950, p. 77.

^C Cannon, M. R. *Industrial and Engineering Chemistry*, Vol 41, No. 9, 1949, p. 1953.

^D Bulletin 23, Scientific Development Co. P.O. Box 795, State College, PA 16801.

^E Cooke, G. M. *Analytical Chemistry*, Vol 39, 1967, p. 286.

^F Bulletin of Podbielniak Div. of Reliance Glass Works, P.O. Box 825, Bensenville, IL 60106.

^G Feldman, J., et al, *Industrial and Engineering Chemistry*, Vol 45, January 1953, p. 214.

^H Helipak Performance Characteristics, Begemear, C. R. and Turkal, P. J. (Laboratory Report of Podbielniak Inc.), 1950.

^I Umholtz, C. L. and Van Winkle, M. *Petroleum Refiner*, Vol 34, 1955, p. 114 for NH:MCH. Pressure Drop Calculated from data obtained on *o*- and *m*-xylene binary.

^J Oldershaw, C. F. *Industrial and Engineering Chemistry*, Vol 13, 1941, p. 265.

^K Bragg, L. B. *Industrial and Engineering Chemistry*, Vol 49, 1957, p. 1062.

^L NA = not applicable.

TABLE 2 North American Sources of Commercially Available Packing Materials

Name	Size	Source
Propak	6 mm by 6 mm	Scientific Development Co. P.O. Box 795 State College, PA 16801
Helipak	2.5 mm by 4 mm	Reliance Glass Works Inc. P.O. Box 825 Bensenville, IL 60106
Perforated plates	25 mm and 50 mm	Reliance Glass Works Inc. P.O. Box 825 Bensenville, IL 60106 W.A. Sales Inc. 419 Harvester Ct. Wheeling, IL 60090
Knitted wire mesh- Goodloe multiknit		Pegasus Industrial Specialties Ltd. P.O. Box 319 Agincourt, Ontario MIS 3B9 Canada Packed Column Co. 970 New Durham Rd. Edison, NJ 08817

accuracy of better than 90 % between the column and the takeoff line over a range of rates from 25 % to 95 % of the maximum boilup rate of the column when determined in accordance with **Annex A7**.

6.1.4 Condenser—The condenser shall have sufficient capacity to condense essentially all the C₄ and C₅ vapors from the crude at the specified rate, using a coolant temperature of –20 °C.

6.1.5 Cold Traps—Two efficient traps of adequate capacity cooled by dry ice and alcohol mixture shall be connected in

series to the vent line of the condenser when light hydrocarbons are present, as at the beginning of the distillation. For vacuum distillation, a Dewar-style trap also cooled by dry ice is used to protect the vacuum gauge from vapors.

6.1.6 Gas Collector—If uncondensed gas is to be measured, a gas meter can be connected to the outlet of the cold trap but with a calcium chloride drying tube between them to keep moisture from collecting in the traps. When analysis of the gas sample is required, the gas can be collected in an empty plastic balloon of suitable size either in place of the meter or following it. The volume of its contents can be determined by calculation from the rise in pressure after expanding the sample into an evacuated vessel of known volume.

6.1.7 Fraction Collector—This part of the apparatus permits the collection of the distillate without interruption during withdrawal of product from the receiver under atmospheric or reduced pressure. It also permits removal of product from the vacuum system without disturbing conditions in the column.

6.1.8 Product Receivers—The receivers shall be of suitable size for the quantity of crude petroleum being distilled. The recommended capacity is from 100 mL to 500 mL. They shall be calibrated and graduated to permit reading to the nearest 1 %.

6.2 Distillation Under Reduced Pressure—In addition to the apparatus listed in **6.1**, the apparatus for distillation under reduced pressure shall include the following:

6.2.1 Vacuum Pump—The vacuum system shall be capable of maintaining smooth pressure operation at all pressure levels.

It shall have the capacity to draw down the pressure in the receiver(s) from atmospheric to 0.25 kPa (2 mm Hg) in less than 30 s so as to avoid disturbance of the system during emptying of receivers under vacuum. Alternatively, a separate pump can be employed for this purpose.

6.2.2 *Vacuum Gauge*—The point of connection of the vacuum gauge to the system shall be as close as practical to the reflux dividing head. The connecting tubing shall be of sufficient diameter to ensure that no measurable pressure drop occurs in the line. In no case shall the vacuum gauge connection be near the vacuum pump.

6.2.2.1 All gauges shall be carefully protected from condensable vapors, especially water vapor, by a cold trap maintained at the temperature of dry ice.

6.2.3 *Pressure Regulator*—The regulator shall maintain the pressure in the system essentially constant at all operating pressures. Automatic regulation can be achieved by a device that regulates the demand on the vacuum source. A satisfactory device is a solenoid valve positioned between the vacuum source and a surge tank of at least 10 L capacity. Alternatively, a manual bleed valve can be maintained by a trained operator with a minimum of attention.

6.3 *Sensing and Recording Apparatus:*

6.3.1 *Temperature Sensors*—Only temperature measurement systems meeting the requirements of 6.3.1.1 and 6.3.1.2 shall be used.

6.3.1.1 The vapor temperature sensor can be a platinum resistance thermometer, a Type J thermocouple with the junction head fused to the lower tip of the thermowell, or any other device that meets the requirements in this paragraph and 6.3.1.2. The tip of the sensor shall be located above the top of the packing or the topmost glass plate and in close proximity to the reflux divider but not in contact with the liquid reflux. The location of the vapor temperature sensor shall be proved by the test method described in Annex A4. The sensor shall have a cooling time of not more than 175 s, as described in Annex A5.

6.3.1.2 The vapor temperature measuring device shall have an accuracy of 0.5 °C or better and be measured with a resolution of 0.1 °C or better. The liquid temperature measur-

ing device shall have an accuracy of 1.0 °C or better and be measured with a resolution of 0.5 °C or better. Temperatures are recorded either manually or automatically.

6.3.1.3 Temperature sensors shall be calibrated as described in Annex A6. Alternatively certified sensors may be used, provided the calibration of the sensor and its associated recording instrument can be traced back to a primary temperature standard. Temperature sensors are calibrated over the full range of temperature (from 0 °C to 400 °C) at the time of first use of the sensor in combination with its associated instrument. Recalibrate when either the sensor or the instrument is repaired or serviced. Verification of the calibration of the temperature sensors is to be made on a regular basis. For vapor temperature sensors, verification at least once a month is recommended and for liquid temperature sensors once every six months. Verification of the calibration of the sensors can be accomplished potentiometrically by the use of standard precision resistance or by distilling a pure compound with accurately known boiling point.

6.3.2 *Vacuum Gauge*—Primary standards, such as the non-tilting McLeod gauge, mercury manometer, or other analogous primary standard pressure devices can be used without calibration when properly used and maintained. A mercury manometer, however, will only be of satisfactory accuracy down to a pressure of about 1 kPa and then only when read with a good cathetometer (an instrument based on a telescope mounted on a vernier scale to determine levels very accurately). Alternatively, a tensimeter or certified electronic sensors may be used, provided the calibration of the sensor and its associated recording instrument can be traced back to a primary pressure standard. Sensors of the diaphragm type have been found satisfactory. Vacuum gauges based on hot wires, radiation, or electrical conductivity detectors are not recommended.

6.3.2.1 The gauge for measuring subatmospheric pressures shall have an accuracy at least equal to that stated as follows:

Distillation Pressure		Accuracy	
kPa	mm Hg	kPa	mm Hg

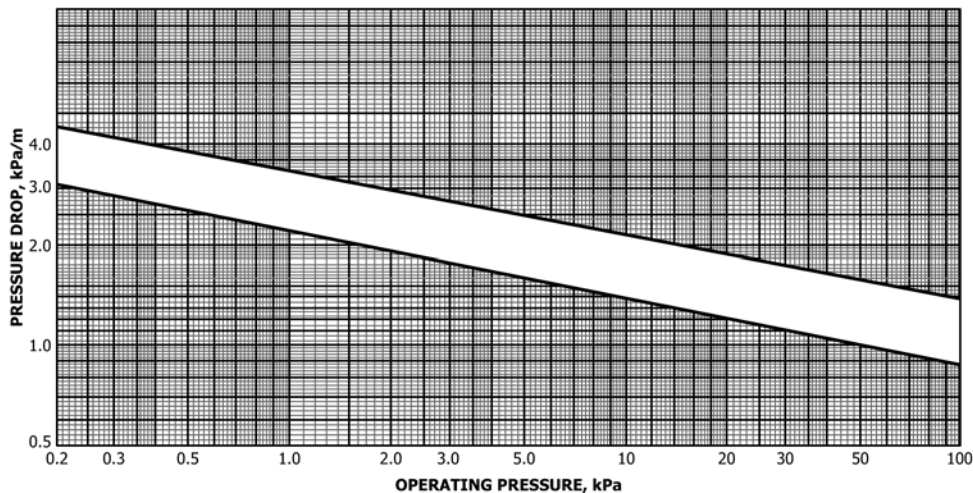

FIG. 2 Approximate Pressure Drop-Fractionators Using Propak

100-13.3	760 to 100	0.13	1.0
13.3-1.33	99 to 10	0.013	0.1
1.33-0.266	9 to 2	0.006	0.06

6.3.2.2 Noncertified gauges shall be calibrated from a primary standard or a secondary electronic standard traceable to a primary standard. A basic calibration procedure is described in [Annex A6](#). Recalibrate when either the sensor or the instrument is repaired or serviced. Verification of the calibration of the electronic pressure sensors is to be made on a regular basis. A frequency of at least once a month is recommended. Verification of the calibration of the sensors can be accomplished using the procedures described in [Annex A6](#) or against a certified reference system.

6.3.3 *Boilup Rate*—The boilup rate is normally controlled by sensing the pressure drop in the column. The pressure drop during operation is measured by means of a manometer or pressure transducer connected between the flask and the condenser. Prevention of condensation in the connecting tube can be accomplished by injecting a very small flow of nitrogen (8 cm³/s) between the pressure drop sensor manometer and the flask (see [Fig. 1](#)) or by placing a small water-cooled condenser between the flask and the pressure drop sensor. Alternatively, the boilup rate can be controlled from the measurement of take off rate.

7. Verification of Apparatus Performance

7.1 Test Method D2892 provides a standard framework for the laboratory distillation of crude oils in order to produce cuts of defined quality (for further testing) and the concurrent production of a boiling point curve. As the quantity requirements and cut points might be widely different between companies and application areas, this test method does not standardize on equipment design but on equipment performance.

7.2 The nature of the test method (the use of large sample quantities and very time consuming) and the nature of the product being tested (highly volatile and unstable material), precludes the use of standard statistical control techniques. Moreover, this test method does not produce a single result, nor is the series of results (the boiling point curve) derived under rigidly defined conditions (see [4.2](#)).

7.3 Equipment performance in the context of Test Method D2892 consists of two elements; the efficiency of the column, defining cut quality, and the correctness of the cut point (AET), defining the boiling point curve.

7.4 The correctness of the AET is mainly, but not only, dependent on the accuracy of the (vapor) temperature and (operating) pressure sensors ([Annex A6](#)). Other factors affecting the accuracy and precision of the boiling point curve are:

7.4.1 The location of the temperature and pressure sensor ([Annex A4](#)).

7.4.2 The dynamic response of the sensors ([Annex A5](#)).

7.4.3 The correct operation of the reflux divider ([Annex A7](#)).

7.4.4 The heat loss from the column ([Annex A3](#)).

7.4.5 The efficiency of the column ([Annex A1](#)).

7.4.6 These factors are basically covered through the appropriate annexes. However, it should be realized that this takes

care only of individual components and does not cover the combined effect of small deviations. Moreover, the aforementioned tests are all done under more or less static conditions, not necessarily representative for the behavior of the system under actual dynamic conditions.

7.5 Cut quality is mainly defined by the efficiency of the column ([Annex A1](#)), but is also affected by:

7.5.1 The correct operation of the reflux divider (reflux ratio) ([Annex A7](#)).

7.5.2 The heat loss from the column, that is, internal reflux ([Annex A3](#)).

7.5.3 The dynamic hold up of the column ([Annex A2](#)).

7.5.4 Column efficiency is covered in this test method through [Table 1](#) and [Annex A1](#). However, [Table 1](#) only provides an assumption on efficiency and is not a guarantee. [Annex A1](#) only provides a check under static conditions, infinite reflux ratio, rather low actual temperatures and a binary component system. Hence, although there is some safeguard on standard performance, through conformance to [Annex A1](#), [Annex A2](#), [Annex A3](#), and [Annex A7](#), again it remains questionable whether this is truly representative for columns under actual operating conditions.

7.6 Theoretically, an overall performance check, like the one described in [Appendix X2](#), is capable of verifying the performance of a column and the correctness of the AET under actual operating conditions. [Appendix X2](#), in principle, measures the combined effect of all factors affecting the results of Test Method D2892.

7.6.1 The minimum tray number as defined in [Appendix X2](#) is a measure of overall cut quality, and the difference between nominal cut point (AET) and effective cut point (ECP as defined in [Appendix X2](#)) provides a measure for the correctness of the AET. However, insufficient data are available right now to define the allowable tolerances in a rigid statistical way. Moreover, the test method described is very labor intensive and precludes its use on a regular, short time interval basis and, therefore, its use as a mandatory statistical control technique.

7.6.2 [Appendix X2](#), therefore, provides only recommended guidelines for statistical control on column performance, including both correctness of AET and column efficiency. It is the responsibility of the laboratory to provide for sufficient quality controls to guarantee conformance to the test method.

8. Sampling

8.1 Obtain a sample for distillation in accordance with instructions given in Practice [D4057](#) or [D4177](#). The sample must be received in a sealed container and show no evidence of leakage.

8.2 Cool the sample to between 0 °C and 5 °C by placing it in a refrigerator for several hours (preferably overnight) before opening.

8.3 If the sample appears waxy or too viscous, raise the temperature to 5 °C above its pour point.

8.4 Agitate the sample by whatever means are appropriate to its size to ensure that it is well mixed.

8.5 Determine the water content of the sample by Test Method **D4006** or any other suitable method. If the water content exceeds 0.3 % volume, the sample shall be dehydrated prior to fractional distillation. A suitable practice for dehydration of wet crude oil samples is described in **Appendix X1**.

NOTE 4—Attempts to distill wet crude oil samples in glass columns might result in breakage of the glassware, which poses a potential fire hazard. Moreover, the presence of water will affect the accuracy of distillation yield in the naphtha region. These effects are more pronounced for heavy crude oils, containing low amounts of hydrocarbons boiling below 100 °C, than for light crudes where there is usually sufficient hydrocarbon vapor generated to form an azeotrope and drive the water vapors through the column without problems.

9. Preparation of Apparatus

9.1 Clean and dry the distillation column and all the ancillary glass apparatus before the distillation begins.

9.2 Ensure that the system is leak-free and all heaters, control devices, and instruments are on and in working order. A clock or other timing device should be ready for use.

10. Procedure

10.1 Charging:

10.1.1 The charge size shall be such that the dynamic hold up as determined in accordance with **Annex A2** is between 1 % and 4 % of the charge when operating at 75 % of maximum boilup (see **Table 1**). Chill the flask to a temperature not lower than 0 °C.

10.1.2 Insert the stirring device or place some pieces of glass or porcelain into the flask to control bumping.

10.1.3 Determine the density of the sample by Test Method **D941**, **D1217**, or **D1298**.

10.1.4 Calculate to within ± 5 % the mass of crude petroleum corresponding to the desired volume of the charge. Weigh to the nearest 1 % this quantity of sample into the flask.

10.1.5 Attach the flask to the column and connect the pressure drop measuring device. Install the heating system, stirrer, and support device. (**Warning**—Poisonous H₂S gas is frequently evolved from crude oil and precautions must be taken either to absorb the gas that passes through the cold trap or to vent it to a safe place.)

10.2 Debutanization:

10.2.1 For necessary apparatus refer to **6.1.5** and **6.1.6**.

10.2.2 Begin circulation of refrigerant at a temperature no higher than -20 °C in the condenser, distillate cooler, and receiver, if so equipped.

10.2.3 Record the barometric pressure at the beginning and periodically throughout the distillation.

10.2.4 Apply heat to the flask at such a rate that vapors reach the top of the column between 20 min and 50 min after startup. Adjust heat input so as to achieve a pressure drop of less than 0.13 kPa/m (1.0 mm Hg/m) in packed columns or less than 0.065 kPa (0.5 mm Hg) in real plate columns. Program automated equipment in accordance with the preceding directions. Turn on the stirring device if used.

10.2.5 Allow the column to operate at total reflux until the vapor temperature reaches equilibrium but not longer than 15 min after the first drop of condensate appears in the reflux divider.

10.2.6 Record the vapor temperature as the initial vapor temperature.

10.2.7 Stop the circulation of the refrigerant and observe the vapor temperature. When the vapor temperature reaches 15 °C, start the circulation of refrigerant again.

10.2.8 If the vapor temperature drops below 15 °C, continue refluxing for at least 15 min. Repeat **10.2.7**. If the vapor temperature remains at 15 °C or rises, continue with the atmospheric distillation. (**Warning**—The following three steps should not be done until after the first naphtha cut has been removed to ensure that all the light gases have been recovered.)

10.2.9 Remove and weigh the dry ice traps containing light hydrocarbon liquid after carefully wiping them dry.

10.2.10 Sample the contents of the first dry ice trap using a 10 mL to 50 mL pressure vessel evacuated to no lower than 26.6 kPa (200 mm Hg). Keep all containers at the temperature of dry ice to ensure no loss of volatiles. The first trap next to the condenser should contain all of the sample. If condensate is found in the second trap, sample both traps or combine the contents before sampling.

10.2.11 Submit the trap sample and gas balloon, if used, for analysis by a suitable gas chromatographic test method to be reported on a fixed-gas free basis. Test Methods **D6729**, **D6730**, and **D6733**, equipped with liquid or gas sampling valves, or both, for sample introduction equipment have been used successfully for this analysis.

10.3 Distillation at Atmospheric Pressure:

10.3.1 Maintain a temperature below -20 °C in the lines of the distillate cooler and receiver as well as in the condenser. Turn on the column mantle heat controller and maintain the column jacket temperature 0 °C to 5 °C below the vapor temperature.

10.3.2 Regulate the heat input as necessary to establish and maintain a boilup rate approximately 75 % of maximum. **Fig. 3** can be used as a guide for Propak. Rates for other sizes can be estimated by multiplying the boilup rate in **Table 1** by the cross-sectional area of the column and dividing by the sum of the reflux ratio + 1.

NOTE 5—Boilup rate is expressed in millilitres of liquid per hour for a given column or in millilitres per hour per square centimetre of cross-sectional area for comparative purposes. In the latter case, it refers to the test mixture of *n*-heptane and methylcyclohexane in the efficiency evaluation (see **Annex A1**) and is measured at the bottom of the column. The maximum boilup of the *n*-heptane-methylcyclohexane test mixture is that which the column can handle under stable conditions without flooding. In routine adiabatic operation, the boilup rate can be estimated roughly from the takeoff rate multiplied by the reflux ratio plus one.

10.3.3 Commence takeoff at a reflux ratio of 5:1 and total cycle time of not over 30 s nor less than 18 s.

NOTE 6—The vapor reaching the top of the column is totally condensed and the resulting liquid is divided into two parts. One part *L* (reflux), is returned to the column and the other part, *D* (distillate), is withdrawn as product. The reflux ratio ($R = L/D$) can vary from zero at total takeoff ($L = 0$) to infinity at total reflux ($D = 0$).

10.3.4 Take off distillate in separate and consecutive fractions of suitable size. The recommended size of fraction is that corresponding to 5 °C or 10 °C in vapor temperature. Collect fractions boiling below 65 °C in receivers cooled to 0 °C or below. When the vapor temperature reaches 65 °C, refrigerant

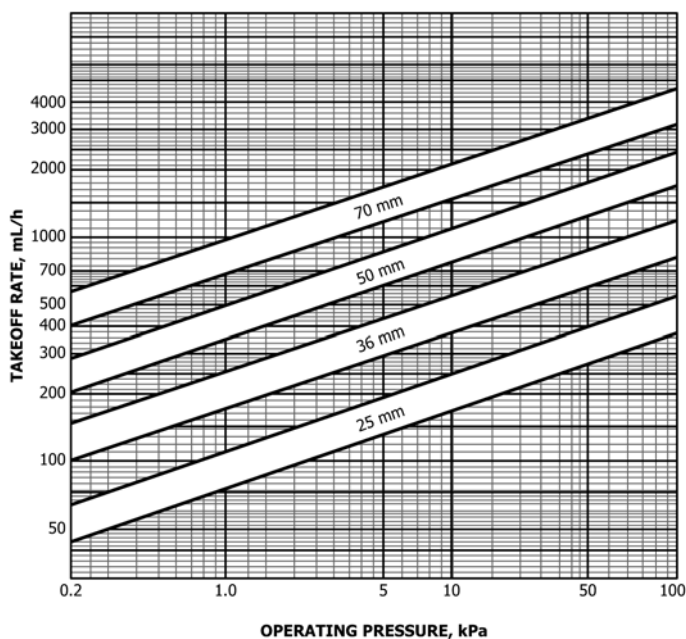

FIG. 3 Expected Takeoff Rates at 5:1 Reflux Ratio for Fractionators Using Propak

in the condenser and related coolers can be discontinued and water at ambient temperature substituted.

10.3.5 At the end of each fraction and at each cut point, record the following observations:

10.3.5.1 Time in hours and minutes,

10.3.5.2 Volume in millilitres,

10.3.5.3 Vapor temperature in °C to the nearest 0.5 °C,

10.3.5.4 Temperature of the boiling liquid in °C to the nearest 1 °C,

10.3.5.5 Atmospheric pressure in kPa (mm Hg), and

10.3.5.6 Pressure drop in the column in kPa (mm Hg).

10.3.6 If signs of flooding are observed, reduce the heating rate while continuing takeoff until steady conditions are restored. If a cut point is encountered during this period, stop the distillation, cool the charge, and recombine the off-condition cuts. Restart the distillation with a period at total reflux, not to exceed 15 min, to restore operating conditions before continuing takeoff. Do not make a cut within 5 °C of startup.

10.3.7 Continue taking cuts until the desired maximum vapor temperature is reached or until the charge shows signs of cracking. Pronounced cracking is evidenced by a fog appearing in the flask and later at the reflux divider. Do not allow the vapor temperature to exceed 210 °C nor the temperature of the boiling liquid to exceed 310 °C.

10.3.8 Shut off the reflux valve and the heating system. Allow the contents to cool to such a temperature that the distillation can be commenced at 13.3 kPa (100 mm Hg) without flooding. This temperature can be estimated by adding the ΔT between the liquid and vapor temperatures found for the column during atmospheric operation to the expected initial vapor temperature at the reduced pressure, or by subtracting the ΔT from the last recorded liquid temperature.

NOTE 7—Cooling of the liquid in the flask can be accelerated by

blowing a gentle stream of compressed air onto the flask after its heating mantle has been removed. Avoid strong jets of cold air. Alternately, turn on coolant in the quench coil of the flask, if used.

10.3.9 Weigh all fractions and determine their densities.

10.3.10 Submit the first distillate fraction for analysis by gas chromatography.

10.4 Distillation at 13.3 kPa (100 mm Hg):

10.4.1 If further cuts at higher temperatures are required, distillation can be continued at reduced pressures, subject to the maximum temperature that the boiling liquid will stand without significant cracking. This is about 310 °C in most cases. Notable exceptions are crude oils containing heat-sensitive sulfur compounds. In any case, do not make a cut within 5 °C of the temperature at startup because the column will not be at equilibrium.

10.4.2 Connect a vacuum pumping and control system to the apparatus as shown in Fig. 1.

10.4.3 Start the vacuum pump and adjust the pressure downward gradually to the value of 13.3 kPa (100 mm Hg) or set the pressure regulator at this value. The temperature of the liquid in the flask must be below that at which it will boil at 13.3 kPa (100 mm Hg). If the liquid boils before this pressure is reached, increase the pressure and cool further until the desired pressure can be achieved without boiling.

10.4.4 Apply heat to the boiler and reestablish reflux at any moderate rate in the reflux divider for about 15 min to reheat the column to operating temperature. Momentarily stop heat input and raise the pressure with N_2 for 1 min to drop the holdup into the distillation flask.

10.4.5 Reapply heat to the distillation flask and adjust the rate of heating to maintain a constant pressure drop equivalent to the boilup rate of approximately 75 % of the maximum rate for this pressure and begin takeoff without delay. The approximate pressure drops required for this purpose are indicated in Fig. 3. Maintain a column insulation temperature 0 °C to 5 °C below the vapor temperature throughout the operation.

10.4.6 Remove separately, cuts of suitable size as in 10.3.4.

10.4.7 At the end of each distillate fraction and at each cut point, record the following observations:

10.4.7.1 Time in hours and minutes,

10.4.7.2 Volume in millilitres observed at ambient temperature,

10.4.7.3 Vapor temperature in °C to the nearest 0.5 °C with correction, if any,

10.4.7.4 Temperature of the boiling liquid in °C to the nearest 1 °C,

10.4.7.5 Pressure drop in the column in kPa (mm Hg),

10.4.7.6 Operating pressure measured at the top of the column in kPa (mm Hg) absolute with correction, if any, and

10.4.7.7 AET using the equations given in Annex A8.

10.4.8 Continue taking cuts until the desired maximum point is reached or until the charge shows signs of cracking. Pronounced cracking is evidenced by the evolution of gases as indicated by rising pressure as well as a fog appearing in the flask (see Note 7). Do not allow the temperature of the boiling liquid to exceed 310 °C. (**Warning**—Automatic vacuum controllers could mask a slight rise in pressure due to cracking. Vigilance is required to avoid this.)

10.4.9 Shut off the reflux valve and the heating system. Allow the contents to cool to such a temperature that the distillation can be commenced at a lower pressure without boiling. This temperature can be estimated by adding the ΔT between the liquid and vapor temperatures found for the column during operation to the expected initial vapor temperature at the lower pressure, or by subtracting the ΔT from the last recorded liquid temperature.

10.4.10 Weigh all fractions and determine their densities at 15 °C.

10.5 Distillation at Lower Pressures:

10.5.1 If the final cut point has not been reached, distillation can be continued at a lower pressure subject to the same limitation as before (see 10.4.1). Only one pressure level between 13.3 kPa (100 mm Hg) and 0.266 kPa (2 mm Hg) is permitted. Where the maximum cut point is 400 °C AET, the minimum pressure is recommended.

10.5.2 Adjust the pressure to the desired level. If the liquid boils before the pressure is reached, increase the pressure and cool further until the desired pressure can be achieved without boiling. Follow the procedure in 10.4.4.

10.5.3 Circulate cooling water in the condenser and liquid cooler either at ambient temperature or warmed to a temperature that will ensure that wax does not crystallize in the condenser or takeoff lines. Alternatively, leave the cooling coils full of water but vented and not circulating, or else circulate a stream of air instead of water as a coolant.

10.5.4 Continue vacuum operation as in 10.4.5 through 10.4.8. During this operation, a reflux ratio of 2:1 is allowed if mutually agreed upon in advance and noted in the report. Correct observed and corrected vapor temperatures to AET using the equations given in Annex A8.

10.5.5 Check periodically that the condensate drips normally in the condenser and that the distillate flows smoothly into the takeoff line. If crystallization is observed, allow the coolant in the condenser to warm as in 10.5.3.

10.5.6 When the final cut point has been reached, or when limits of boiling liquid temperature and column pressure prevent further distillation, turn off the reflux valve and heating system and allow to cool with the vacuum still applied.

10.5.7 When the temperature of the residue in the flask has fallen below 230 °C, shut off the vacuum pump. Vent the fractionating unit with nitrogen or other inert gas. Do not use air. (**Warning**—Air is suspected of initiating explosions in fractionating units that are vented while too hot, such as at the end of a run.)

10.5.8 Stop circulation of coolant in the condenser and ancillary equipment. Disconnect the flask. Recover the static holdup of the column (wettage) by distilling a small quantity of solvent such as toluene in a separate flask to wash the column, condenser, and takeoff system. Evaporate the solvent from the collected residue at 10 °C above the boiling point of the solvent, using a small purge of nitrogen. For distillations not involving disagreement, or by mutual consent, the holdup can be estimated using a graph similar to Fig. 4. The density of the holdup is estimated by extrapolation of the density line for the preceding cuts. The static holdup can be treated as a separate small cut or blended into the bottoms before inspections are

made. The latter must be done if other analyses besides density are to be performed on the residue.

10.5.9 Weigh all fractions and the residue in the flask and determine their densities at 15 °C by Test Method D4052 or by another suitable method. Convert the density to 15 °C, if necessary.

NOTE 8—Heavier flasks, such as those for 50 mm and 70 mm diameter columns, are not normally removed for weighing. In these cases the residue can be discharged at a temperature not over 200 °C into a tared container for weighing. Nitrogen pressure of approximately 6.7 kPa (50 mm Hg) will be sufficient for this. Wettage in these cases will include that of the column and the flask together.

11. Calculation

11.1 Calculate the mass % of each distillate fraction and the residue to the 0.1 mass %, using Eq 1.

$$\text{mass \%} = 100(m/M) \quad (1)$$

where:

m = mass of fraction or residue, g, and
 M = mass of dry crude oil charged, g.

11.1.1 The first fraction is the gas fraction collected in the balloon. If this fraction is less than 0.1 mass %, it can be ignored.

11.1.2 The second fraction (or first, if no gas is collected) is the condensate in the dry ice trap. With density at 15 °C calculated from the gas chromatographic data on a fixed gas free basis, its volume can be computed.

11.1.3 The holdup is treated either as a separate cut or added to the residue fraction, in accordance with agreement. The amount of holdup is determined by actual recovery by solvent washing, as directed in 10.5.8, or estimated from Fig. 4.

11.2 Calculate the percent loss to the nearest 0.1 mass %, using Eq 2.

$$\text{Loss} = 100 - \left(\sum 100(m/M) \right) \quad (2)$$

The weight loss as calculated above must not be greater than 0.4 %, otherwise the distillation must be discarded. Losses less than this should be allocated two-thirds to the trap cut and one-third to the first naphtha cut. Where there is no trap cut, the acceptable losses are to be normalized among all cuts.

11.3 Calculate the volume of the sample of crude oil in millilitres at 15 °C, using Eq 3.

$$V = (M/D) \quad (3)$$

where:

D = density of charge at 15 °C, g/mL,
 M = mass of dry charge, g, and
 V = volume of charge, mL.

11.4 Calculate the volume of each fraction and of the residue in millilitres at 15 °C, using Eq 4.

$$v = m/d \quad (4)$$

where:

d = density of the fraction or residue at 15 °C, g/mL,
 m = mass of fraction or residue corrected for loss, g, and
 v = volume of fraction, mL.

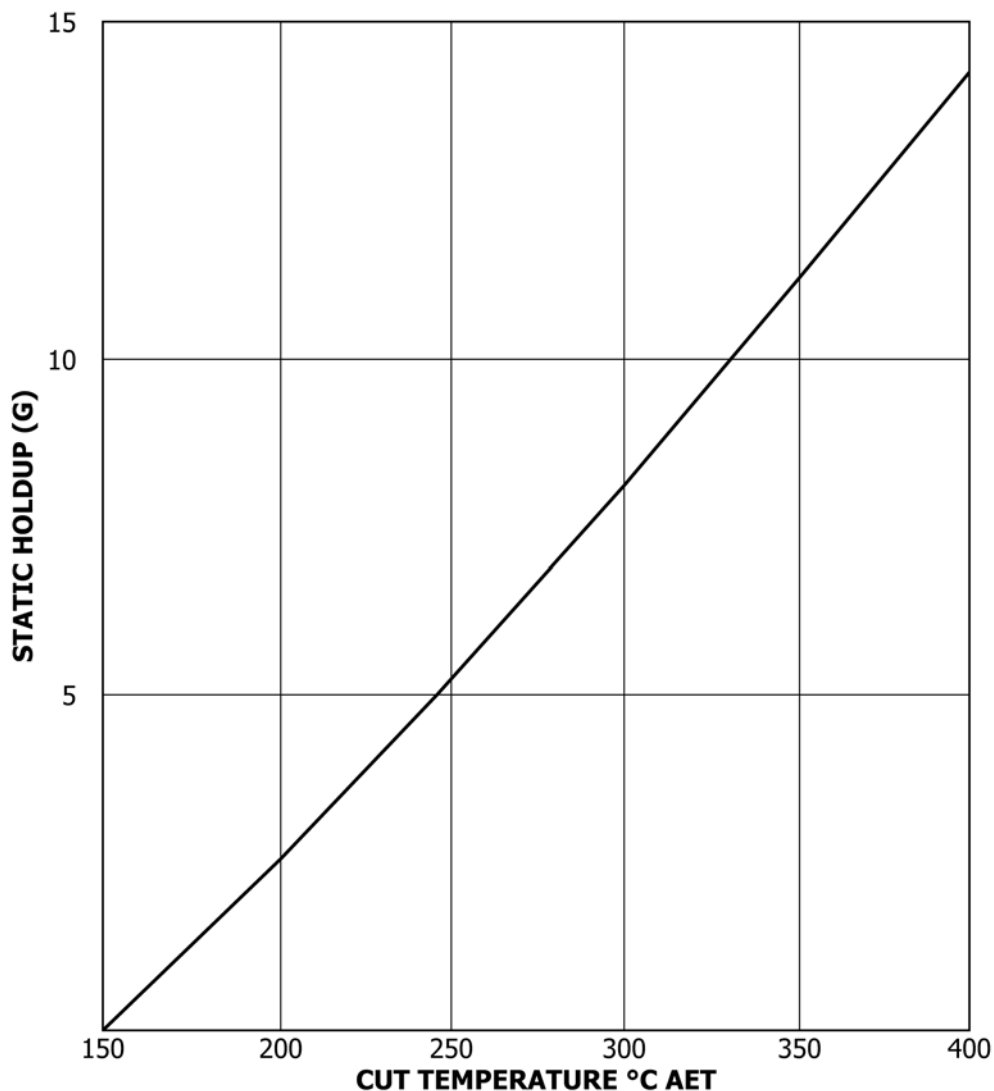

FIG. 4 Approximate Static Holdup for Average Crude Oil Using 4 mm Propak in a 25 mm ID × 570 mm Column

11.5 Calculate the volume % of each distillate fraction to the nearest 0.1 volume %, using Eq 5.

$$\text{vol \%} = 100(v/V) \quad (5)$$

11.6 Calculate the volume % gain or loss to the nearest 0.1 volume %, using Eq 6.

$$\text{Loss} = 100 - \left(\sum 100(v/V) \right) \quad (6)$$

Usually, the above expression is negative due to volume expansion. Normalize any apparent expansion or contraction among fractions boiling below 150 °C in proportion to their yields.

NOTE 9—In view of the foregoing rules for establishing yields, the ratio of mass to volume is not precise enough to be used to calculate the density of any distillate fractions or residue.

12. Report

12.1 A summary sheet for the run must include:

12.1.1 The mass of the dry sample charged, g,

12.1.2 The density of the sample at 15 °C, g/mL,

12.1.3 The volume of the sample at 15 °C, mL,

12.1.4 The gain or loss in mass and volume to the nearest 0.1 %,

12.1.5 The volume and mass % of each fraction to the nearest 0.1 %,

12.1.6 The cumulative volume and mass percentages, and

12.1.7 The mass of water, if any.

12.2 The gas, debutanized naphtha, and succeeding fractions are listed in order of ascending boiling point with residue recorded last.

12.3 The observations made in 10.3.5, 10.4.7, and 10.5.4 are included as a second sheet, which is normally attached to the summary sheet.

12.4 Make plots of the temperature in degrees Celsius AET as the ordinate (y-axis) versus the percentage mass and volume distilled as the abscissa (x-axis). These are the final TBP distillation curves.

13. Precision and Bias⁵

13.1 The precision of this test method, as determined by the statistical examination of interlaboratory test results obtained from eight laboratories on five crude oil samples ranging in gravity from 20.0° to 41.0° API. The sample set contained crudes with high and low sulfur content, high and low naphthenic acid content, and asphaltic types. The results of the statistical examination follow, and the statistical evaluation and validation can be found in the research report.

13.2 *Repeatability*—The difference between successive results obtained by the same operator with the same apparatus under constant operating conditions on identical test material would, in the long run, in the normal and correct operation of this test method, exceed the values indicated as follows in one case in twenty.

	Mass %	Degrees of Freedom
Atmospheric pressure	0.6	19
13.33 kPa Vacuum pressure	0.9	19
1.33 kPa Vacuum pressure	0.9	19

⁵ Supporting data have been filed at ASTM International Headquarters and may be obtained by requesting Research Report RR:D02-1705. Contact ASTM Customer Service at service@astm.org.

13.3 *Reproducibility*—The difference between two single and independent results obtained by different operators working in different laboratories on identical test material would, in the normal and correct operation of this test method, exceed the values indicated as follows in one case in twenty.

	Mass %	Degrees of Freedom
Atmospheric pressure	1.3	16
13.33 kPa Vacuum pressure	1.5	25
1.33 kPa Vacuum pressure	2.0	15

13.4 Bias:

13.4.1 *Absolute Bias*—Since there is no accepted reference material suitable for determining the bias for the procedure in Test Method D2892 in determining distillation properties of crude petroleum, bias cannot be determined.

13.4.2 *Relative Bias*—TBP is defined under the conditions of this test method (see 1.2).

NOTE 10—The degrees of freedom associated with the repeatability/reproducibility estimate from this round-robin study ranged from 15 to 25. Since the minimum requirement of 30 (in accordance with Practice D6300) is not met, users are cautioned that the actual repeatability/reproducibility may be significantly different than these estimates. Given the fact that it is very difficult to get laboratories to participate, coupled with the logistical difficulties of shipping precision study samples in the quantities required, the members of Subcommittee D02.08 have decided to publish all precision data, despite the lower degrees of freedom.

14. Keywords

14.1 boiling point distillation; crude oil distillation; distillation; fractional distillation; TBP curves

ANNEXES

(Mandatory Information)

A1. TEST METHOD FOR THE DETERMINATION OF THE EFFICIENCY OF A DISTILLATION COLUMN

A1.1 Scope

A1.1.1 This test method is for determining the efficiency of a distillation column, under total reflux conditions using the test mixture *n*-heptane/methylcyclohexane at atmospheric pressure.

A1.1.2 The efficiency is not measured under vacuum conditions because there is no satisfactory test mixture that has a constant relative volatility with pressure.

A1.2 Significance and Use

A1.2.1 The efficiency of the distillation column must be between 14 and 18 theoretical plates to be used in Test Method D2892 (see 6.1.3.2).

A1.2.2 The performance of particulate packings is well established in the literature. The data shown in Table 1 can be used in place of this test method.

A1.3 Apparatus

A1.3.1 An example of a suitable apparatus is shown in Fig. A1.1. It consists of the following:

A1.3.1.1 *Calibration Flask*, of suitable size with a device for heating. An example of a suitable calibration flask is shown in Fig. A1.2.

A1.3.1.2 *Distillation Column and Condenser*.

A1.3.1.3 *Manometer*, or equivalent to measure the pressure drop in the column.

A1.4 Reagents and Materials

A1.4.1 The test mixture is a 50/50 mixture by volume of *n*-heptane and methylcyclohexane with refractive indexes of:

<i>n</i> -heptane	$n_D^{20} = 1.38764$
methylcyclohexane	$n_D^{20} = 1.42312$

A1.4.2 Chromatographic analysis of the components of the test mixture must show less than 0.01 % contamination with

lighter compounds and greater than 99.75 % purity. They must be transparent to ultraviolet light at 260 nm to 270 nm to ensure freedom from aromatics.

A1.4.3 If the components do not meet the above specification, they can be purified either by redistillation in a 30 to 50 plate column, or by percolation through 200-mesh silica gel, discarding the first 10 % of the eluted liquid. Exercise care that the gel does not become overloaded.

A1.5 Preparation of Apparatus

A1.5.1 The distillation column and all the glassware must be clean and dry before proceeding with the test method described. Cleaning can be accomplished by washing with a strong industrial detergent. Rinse thoroughly, dry, and reassemble.

A1.5.2 Distill a small quantity of pure *n*-heptane at a high boilup rate for at least 5 min. Take off several small quantities through the overhead sampling system at intervals. Turn off the heat, remove the flask, and dry the column with air while still hot. To keep the apparatus completely dry, connect a moisture trap at the vent of the overhead condenser.

A1.6 Procedure

A1.6.1 Introduce into the distillation flask a quantity of test mixture equal to the minimum volume permitted for the column (see Table 1) but not more than two-thirds of the capacity of the flask. Add some pieces of glass or porcelain to promote even boiling.

A1.6.2 Connect the flask to the pressure drop manometer as shown in Fig. A1.1.

A1.6.3 Circulate water at ambient temperature in the condenser.

A1.6.4 Apply heat to the flask until the test mixture boils, then increase the heat progressively up to the flood point. This will be noted by visible slugs of liquid in the packing or on the plates or by liquid filling the neck of the condenser and a sudden increase in pressure drop. Reduce heat to allow the flooding to subside. Increase the heat gradually to just below the flood point. Record boilup and ΔP measurements just below the flood point. This is considered the maximum rate.

NOTE A1.1—Under these conditions no vapor can reach the head and the heat to the distillation flask must be reduced to establish normal operations again. The flood point is normally determined during the efficiency evaluation of a column using the *n*-heptane-methylcyclohexane test mixture (see Annex A1).

A1.6.5 Adjust the heat input until the column is refluxing at a steady rate corresponding to about 200 mL/h times the cross-sectional area of the column in cm².

A1.6.6 Maintain the column under total reflux for 1 h. Record the pressure drop and determine the boilup rate by timing the filling of the calibrated bulb.

A1.6.7 Take rapidly, and almost simultaneously, a sample of the flask liquid and reflux in sufficient quantity for the determination of the refractive indexes at 20 °C but not more than 0.5 mL each. The duration of withdrawal of the reflux sample must not exceed 2 s.

A1.6.8 Measure refractive indexes of reflux and flask samples.

A1.6.9 Repeat A1.6.7 and A1.6.8 at intervals from 12 min to 30 min until refractive index measurements indicate that steady conditions of maximum efficiency have been attained.

A1.6.10 Check the ultraviolet absorption of the flask sample at 260 nm and 270 nm. If an absorption is detected, aromatics contamination is present and the efficiency determination will be in error. The apparatus must be cleaned and the test mixture re-percolated through fresh silica gel before starting over.

A1.6.11 Repeat successively the series of operations A1.6.5 to A1.6.10, without preflooding, at four or more other boilup rates approximately equally spaced between (200 mL/h) × cm² and the maximum rate. One of these should be at a rate that is above 90 % of maximum.

A1.7 Calculation

A1.7.1 For each pair of samples taken, determine the molar composition of each sample by comparison of its refractive index with a curve of refractive index versus molar composition of *n*-heptane drawn from the following data:

Molar fraction of <i>n</i> -heptane	Refractive Index
0.00	1.4231
0.10	1.4191
0.20	1.4151
0.30	1.4113
0.40	1.4076
0.50	1.4040
0.60	1.4005
0.70	1.3971
0.80	1.3939
0.90	1.3907
1.00	1.3876

A1.7.2 Calculate the number of theoretical plates in the column by means of the Fenske equation⁶ (Eq A1.1):

$$N = \frac{\log \frac{X_D}{1 - X_D} - \log \frac{X_O}{1 - X_O}}{\log \alpha} - 1 \quad (\text{A1.1})$$

where:

N = number of theoretical plates in the column,
 α = relative volatility of *n*-heptane to methylcyclohexane,
 X_D = molar fraction of *n*-heptane in the reflux liquid, and
 X_O = molar fraction of *n*-heptane in the flask liquid.

A1.7.3 Fig. A1.3 is a graphical solution to the equation for the *n*-heptane-methylcyclohexane binary. Vapor-liquid equilibria have been determined by Adler et al.⁷ and relative volatility is taken as 1.075 as recommended by IUPAC.⁸

A1.7.4 The efficiency of the column is numerically equal to the difference between the plate numbers indicated on the curve for top and bottom samples. Note that one plate is subtracted for the contribution of the flask, or alternatively a sample of liquid from the bottom of the column rather than the flask can be taken to obtain the efficiency of the column alone.

⁶ A more convenient form of the equation from Fenske, M. R., *Industrial and Engineering Chemistry*, Vol 24, 1932, p. 482.

⁷ Adler, et al., *American Institute of Chemical Engineers*, Vol 12, 1966, p. 629.

⁸ Seig, *Chemie-Ingenieur-Technik*, Vol 22, 1950, p. 322.

A1.7.5 For packed columns, draw curves of HETP in millimetres, ΔP in kPa and kPa/m, and number of theoretical plates as a function of boilup rate expressed in mL/h and absolute rate in $(\text{mL/h}) \times \text{cm}^2$. For real plate columns, the efficiency should be plotted as percent of a theoretical plate per real plate and ΔP should be plotted both in kPa/real plate and in absolute units of kPa/theoretical plate using the same units for boilup rate as above for packed columns. The efficiency of the column corresponds to the value of N determined from the curve at 75 % of its maximum boilup rate.

A1.7.6 Typical curves for the popular packings and plate columns are shown in Figs. A1.4-A1.7. These columns are to be used in the unpre-flooded condition. Data on other packings are inconclusive or incomplete in the literature and are not included.

A1.7.7 Draw a vertical line on the graph at 75 % of maximum boilup and read the HETP or the plate efficiency corresponding to this rate.

A1.7.8 Multiply the HETP in millimetres by 14 and by 18 for packed columns to obtain the range of permissible heights of packing for use in this test method. If the efficiency of a packed column is greater than 18 plates, as measured above, the efficiency can be reduced by removing a suitable amount of packing without detriment to performance.

A1.7.9 For real plate columns, divide 14 and 18 by plate efficiency to obtain the number of actual plates (rounded to the nearest integer) for an acceptable column.

A1.8 Precision and Bias

A1.8.1 No statement is made concerning either the precision or bias of Annex A1 for measuring the efficiency of a distillation column because the result is used to determine whether there is conformance to the criteria stated in Test Method D2892.

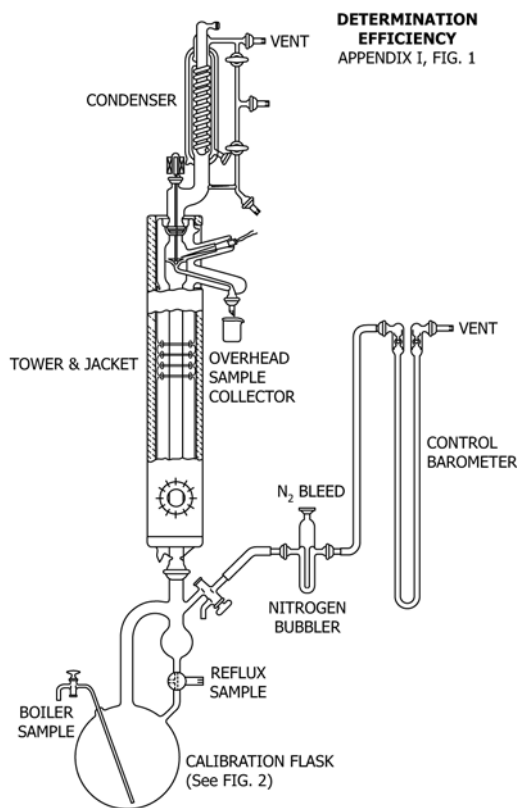

FIG. A1.1 Determination of Efficiency

BOILUP RATE TIMER

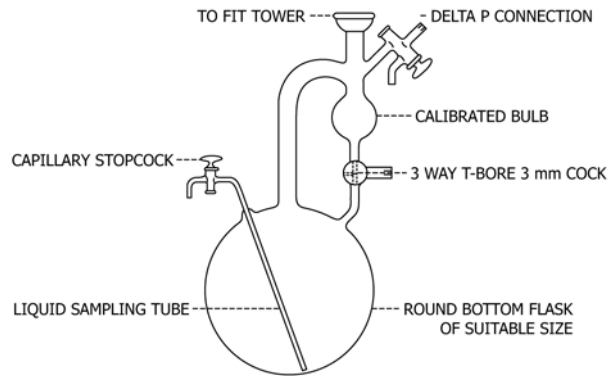

FIG. A1.2 Boiling Rate Timer

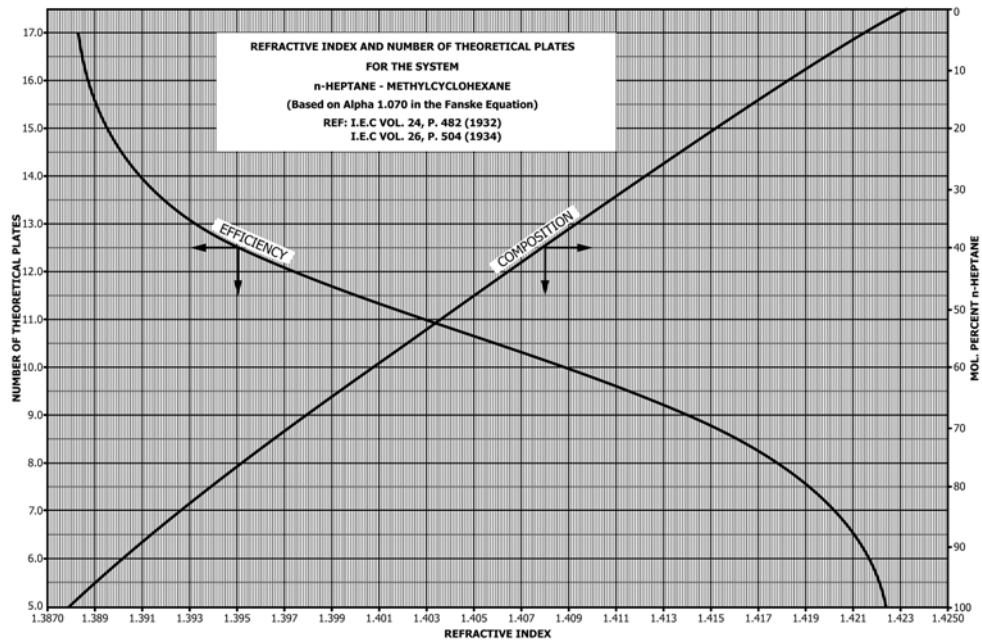

FIG. A1.3 Refractive Index

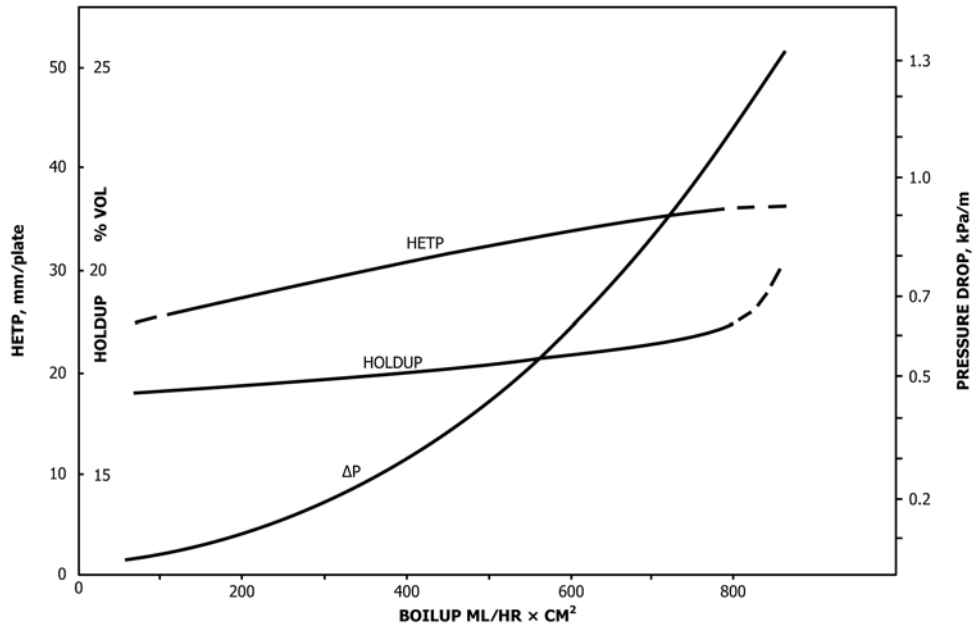

FIG. A1.4 4 mm Propak in 25 mm Inside Diameter Towers

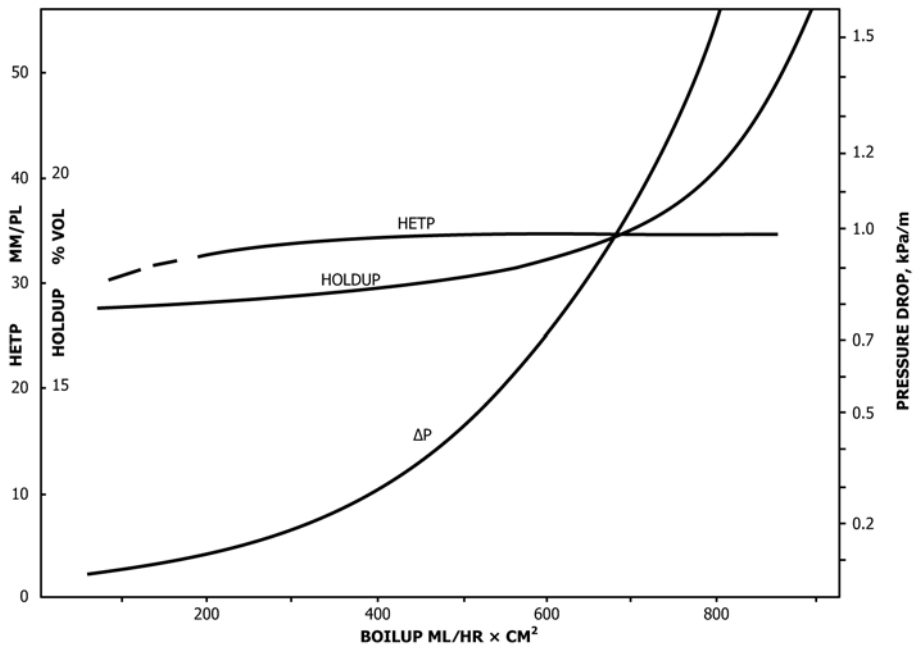

FIG. A1.5 4 mm Propak in 50 mm Inside Diameter Towers

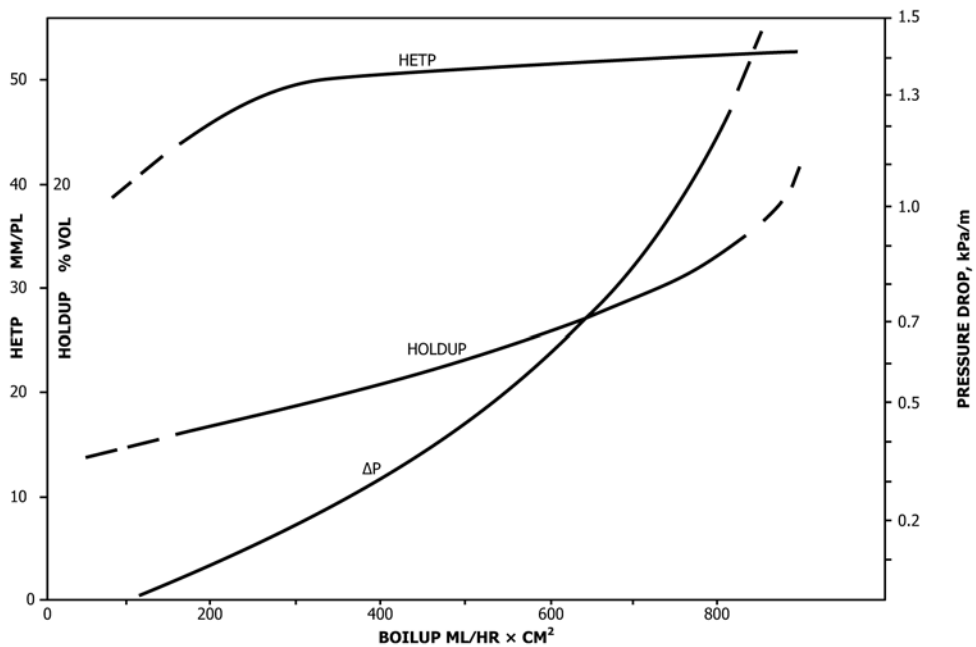
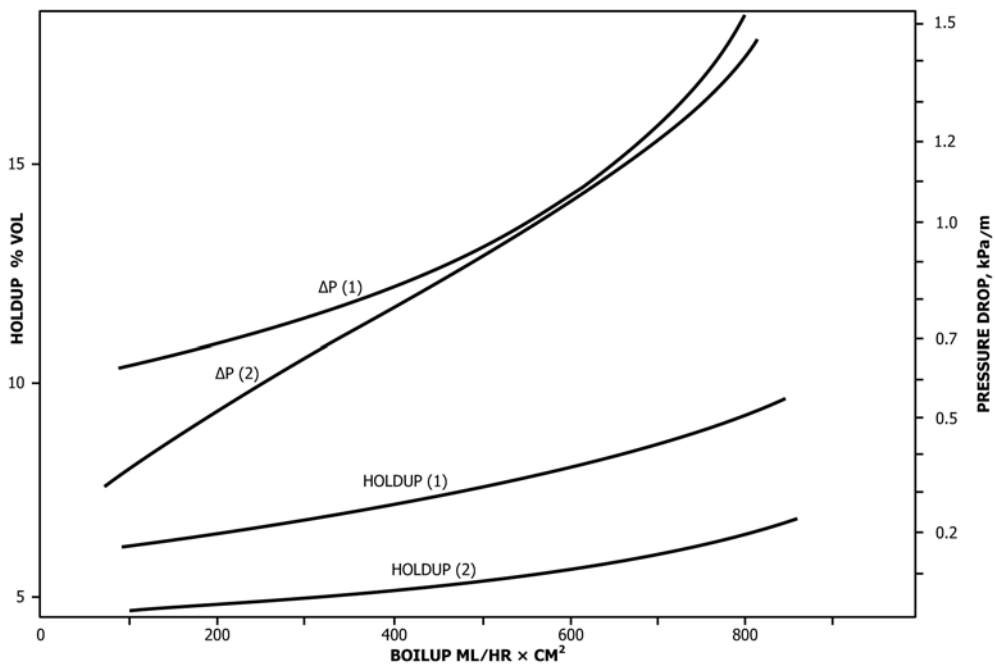

FIG. A1.6 6 mm Propak in 50 mm Towers



NOTE 1—(1) Analytical Chemistry, ANCHA, Vol 39, 1967, p. 286. (2) Exxon unpublished data.

FIG. A1.7 Perforated Plates 50 mm Inside Diameter

A2. TEST METHOD FOR THE DETERMINATION OF THE DYNAMIC HOLDUP OF A DISTILLATION COLUMN

A2.1 Scope

A2.1.1 This test method is for determining the dynamic holdup of a distillation column using a test mixture of stearic acid in *n*-heptane.

NOTE A2.1—Dynamic hold-up is expressed as a percentage of the packed volume for packed columns so that the data can be compared. For real plate columns, it is expressed in millilitres per plate. The data can only be compared with others of the same diameter because of different tray spacing. Data for packed columns cannot be compared with those of real plate columns except in absolute units of millilitres per theoretical plate (see Table 1). Dynamic hold-up increases with increasing distillation rate up to the flood point and varies from one kind of fractionator to another.

A2.2 Summary of Test Method

A2.2.1 A test mixture, composed of stearic acid in *n*-heptane, is distilled under total reflux conditions. From the difference in concentration of stearic acid in the initial mixture and in the mixture during refluxing, the dynamic holdup of the column is calculated.

A2.3 Significance and Use

A2.3.1 The amount of sample charged to a particular distillation column must be of such a size that the dynamic holdup of that column is between 2 % and 4 % of that charge size at 75 % boilup rate (see 10.1.1).

A2.3.2 The performance of the particle packings is well enough defined in the literature that the data in Table 1 can be used instead of this test method.

A2.4 Apparatus

A2.4.1 The apparatus is identical to that described in A1.3, Fig. A1.1.

A2.5 Reagents and Materials

A2.5.1 The test mixture consists of 20 mass % stearic acid in *n*-heptane. The *n*-heptane shall have a refractive index at 20 °C of 1.3878 ± 0.0002 . The stearic acid shall be greater than 95 % pure and have a melting point of 68 °C to 70 °C.

A2.6 Preparation of Apparatus

A2.6.1 See A1.5.

A2.7 Procedure

A2.7.1 Measure the concentration of stearic acid in the test mixture by a convenient means. For example, titrate with 0.1 *N* NaOH solution to a pH of 9.0 potentiometrically. Record the results as mass % stearic acid (P_O).

A2.7.2 Introduce pieces of glass or porcelain into the flask or use a good stirrer to promote even boiling.

A2.7.3 Add 1 L of the test mixture for a 25 mm inside diameter column or 4 L for a 50 mm column to the flask. Weigh the flask to the nearest 1 g.

A2.7.4 Attach the flask to the distillation column and to the ΔP measuring system.

A2.7.5 Circulate water at ambient temperature through the condenser.

A2.7.6 Apply heat to the flask and bring the test mixture to a boil. Adjust the boilup rate to approximately 200 mL/h times the cross-sectional area of the column in centimetres squared measured by timing the filling of the calibrated bulb. When the desired rate has been established, hold for 30 min noting the pressure drop.

A2.7.7 Sample the reflux and the flask liquids, taking samples of not more than the amount necessary for a determination, and immediately observe and record the boilup rate and ΔP .

A2.7.8 Analyze the reflux and flask samples to determine the concentration of stearic acid in mass % (P).

A2.7.9 Repeat A2.7.7 and A2.7.8 at 15 min intervals until the concentration of stearic acid in the flask sample is steady.

A2.7.10 Raise the boilup rate by an additional 200 (mL/h) \times cm² and repeat A2.7.7 – A2.7.9.

A2.7.11 Continue making measurements as above at increments of about 200 (mL/h) \times cm² until near the flood point. At least four sets of measurements should be obtained including one near the maximum operable rate.

A2.8 Calculation

A2.8.1 Calculate the dynamic holdup of the column for each observation, using Eq A2.1:

$$H = \frac{P - P_O}{P} \times \frac{M}{d} \quad (\text{A2.1})$$

where:

H = dynamic holdup in column, mL at 15 °C,
 M = mass of test mixture in the flask, g,
 P_O = stearic acid in the test mixture initially, mass %,
 P = stearic acid in the test mixture after distillation, mass %, and
 d = density of *n*-heptane, 0.688 g/mL at 15 °C.

A2.8.2 Calculate the dynamic holdup per theoretical plate at each rate of boilup at which the determination was made, using Eq A2.2:

$$h = \frac{H}{N} \quad (\text{A2.2})$$

where:

N = efficiency in theoretical plates of the column under total reflux at this boilup rate (see Annex A1).

A2.8.3 Convert the boilup measurement in litres per hour to rates per hour in (mL/h) \times cm². Convert also the ΔP measurements to kPa/m (mm Hg/m) and the holdup measurement to millilitres per theoretical plate.

A2.8.4 Plot all data as ordinates versus boilup rate in litres per hour and (mL/h) \times cm² as abscissa. Draw smooth curves through the points for holdup in millilitres and in millilitres per

theoretical plate. The boilup versus ΔP measurements should be compared with those made in the efficiency measurements if available, to ensure that they are in reasonable agreement.

A2.8.5 Draw a vertical line at 75 % of maximum boilup rate. The dynamic holdup for the column will be that read from the intersection of the holdup curve and the line for 75 % of maximum boilup rate. The charge size, ranging from a holdup ratio from 2 % to 4 % will thus be from 50 to 25 times the above figure.

A3. TEST METHOD FOR THE DETERMINATION OF THE HEAT LOSS IN A DISTILLATION COLUMN (STATIC CONDITIONS)

A3.1 Scope

A3.1.1 This test method is for determining the heat loss of a distillation column under static conditions when a temperature differential exists between the inner and outer walls of a distillation column.

A3.2 Summary of Test Method

A3.2.1 The outer wall of the column vacuum jacket is maintained at an elevated constant temperature. The temperature increase inside the column, as recorded by the sensor in the reflux divider, is a measure of the heat gained and thus heat lost by the column.

A3.3 Significance and Use

A3.3.1 It is important to have an effective silvered glass vacuum jacket surrounding the column and reflux divider. This reduces the effects of ambient air temperature near the distillation apparatus and promotes easier control at the maximum distillation temperatures. The use of a heat compensating mantle further reduces losses by reducing the temperature gradient between inside of the column and the ambient air.

A3.3.2 The test should be performed on all new glass vacuum jackets before use, and checked at least once per year thereafter.

A3.3.3 The heat loss as determined by this test method must be less than 30 % for the column to be acceptable for use in Test Method D2892.

A3.4 Apparatus

A3.4.1 The column is enclosed in its heat compensating mantle with the thermocouple in place on the column wall.

A3.4.2 A twin pen chart recorder to monitor the column outer wall and heat sensor temperatures and an automatic proportioning controller for the heat input are recommended.

A2.9 Precision and Bias

A2.9.1 No statement is made concerning either the precision or bias of [Annex A2](#) for measuring dynamic holdup because the result is used to determine whether there is conformance to the criteria stated in Test Method D2892.

A3.5 Preparation of Apparatus

A3.5.1 The heat sensor location, response time, and calibration must be checked as specified in [Annex A4](#) to [Annex A6](#).

A3.5.2 To reduce chimney effects inside the column during the test, the top of the condenser must be closed.

A3.6 Procedure

A3.6.1 Record the time and ambient temperature.

A3.6.2 Apply heat to the outer wall of the column vacuum jacket. Adjust the heat progressively until the temperature sensor located on the column wall records a temperature 100 °C above ambient. This condition provides a suitable temperature difference to measure without placing unnecessary thermal strain on the glassware. Attain the 100 °C differential temperature within 30 min and maintain the column at this temperature for 1 h.

A3.6.3 Record the time, the temperature of column outer wall, and the temperature inside the column.

A3.7 Calculation

A3.7.1 Calculate the heat gained and thus lost by the column using [Eq A3.1](#):

$$Q = \frac{B - A}{C - A} \times 100 \quad (\text{A3.1})$$

where:

A = ambient temperature, °C,
 B = temperature inside column, °C, and
 C = temperature of outer wall, °C.

or, when the differential temperature is 100 °C, use [Eq A3.2](#):

$$Q = B - A \quad (\text{A3.2})$$

A3.8 Precision and Bias

A3.8.1 No statement is made concerning either the precision or bias of [Annex A3](#) for measuring heat loss because the result is used to determine whether there is conformance to the stated criteria (see [A3.3.3](#)).

A4. TEST METHOD FOR THE VERIFICATION OF TEMPERATURE SENSOR LOCATION

A4.1 Scope

A4.1.1 This test method is for determining whether the temperature sensor is in the proper position for optimum performance.

A4.2 Summary of Test Method

A4.2.1 The vapor temperature of a pure compound measured by the sensor and its recording instrument is compared to the accepted boiling point for the compound. The test is conducted both at atmospheric pressure and under vacuum of 0.133 kPa (1 mm Hg).

A4.3 Significance and Use

A4.3.1 A poorly positioned sensor can give temperatures that are in error due to inadequate heat supply from the vapors. It is especially important under vacuum when heat content of the vapor is at a minimum.

A4.3.2 The procedure is normally performed once only for the approval of a design and need not be repeated thereafter.

A4.4 Procedure

A4.4.1 Atmospheric Distillation:

A4.4.1.1 Assemble the apparatus for atmospheric distillation. Use cooling water at ambient temperature. Charge 0.5 L to 1 L of pure, dry *n*-tetradecane containing less than 0.1 % light contaminants as determined by gas chromatography. Calibrate the temperature sensor as prescribed in [Annex A6](#).

A4.4.1.2 (**Warning**—At atmospheric pressure, the boiling point of tetradecane (253 °C) is above its autoignition temperature in air of 235 °C. Care should be taken to ensure that ambient air is displaced from the distillation apparatus by applying a slow purge (0.5 L/min) of pure nitrogen into the filled distillation flask for at least 15 min prior to heating, and continue this purge during boilup. Careful inspection of fittings and glassware should also be made prior to performing the actions in [A4.4.1.3](#) to avoid a potentially hazardous failure of the equipment during this test. In addition, after performing the test, do not disconnect glassware until the tetradecane liquid in the flask has cooled below 100 °C to avoid ignition of the hot liquid when exposed to air.)

A4.4.1.3 Apply heat and establish equilibrium at a boilup rate of about 400 (mL/h) × cm². This corresponds to a ΔP of about 0.4 kPa/m (3 mm Hg/m) for particle packing or 0.09 kPa/plate (0.07 mm Hg/plate) for real plate columns. Hold at these conditions for 15 min. If the vapor temperature

drops more than 0.2 °C, remove 2 % overhead at 5:1 reflux ratio and then again hold at total reflux for 15 min. Continue taking 2 % cuts as above until the vapor temperature remains steady within 0.2 °C for 15 min at total reflux.

A4.4.1.4 Record the boiling point to the nearest 0.5 °C and the atmospheric pressure to the nearest 0.1 kPa (1 mm Hg), using instruments calibrated in accordance with [Annex A6](#).

A4.4.1.5 If the observed boiling point is not 253.5 °C ± 0.5 °C, the location of the sensor is suspect and must be corrected before use in this test method.

A4.4.2 Vacuum Distillation:

A4.4.2.1 Assemble the apparatus for vacuum distillation. Charge 0.5 L to 1 L of pure, dry *n*-hexadecane containing less than 0.1 % light contaminants as determined by gas chromatography. Calibrate the temperature and vacuum instruments as prescribed in [Annex A6](#).

A4.4.2.2 Reduce the pressure in the system to 0.133 kPa (1 mm Hg). Circulate air in the condenser to avoid crystallization.

A4.4.2.3 Apply heat and establish equilibrium at a boilup rate between 25 and 50 (mL/h) × cm². This corresponds to a ΔP of about 0.133 kPa/m (1 mm Hg/m) or less for particle packing or 0.08 kPa/plate (0.06 mm Hg/plate) for real plate columns to 50 mm diameter. Hold at these conditions for 15 min.

A4.4.2.4 Remove 2 % overhead at 20:1 reflux ratio and then again hold at total reflux for 5 min. Record the boiling point to the nearest 0.5 °C and the operating pressure to the nearest 0.05 kPa (0.3 mm Hg), using instruments calibrated as described in [Annex A6](#).

A4.4.2.5 If the observed boiling point is not steady with 0.2 °C at 0.133 kPa (1 mm Hg), remove 2 % cuts at 5:1 reflux ratio and then hold at total reflux for 15 min, repeating the above until total reflux conditions produce a steady temperature. Not more than three trials should be needed.

A4.4.2.6 If the observed boiling point is not 105.2 °C ± 0.5 °C at 0.133 kPa (1 mm Hg), the location of the sensor is suspect and must be corrected before use in this test method.

A4.5 Precision and Bias

A4.5.1 No statement is made concerning either the precision or bias of [Annex A4](#) for checking the location of the temperature sensor because the result is used to determine whether there is conformance to the criteria stated in [A4.4.2.6](#).

A5. TEST METHOD FOR DETERMINATION OF TEMPERATURE RESPONSE TIME

A5.1 Scope

A5.1.1 This test method is for the determination of temperature response time based upon the rate of cooling of the sensor under prescribed conditions.

A5.2 Significance and Use

A5.2.1 This test method is performed to ensure that the sensor is able to respond to changes in temperature fast enough that no error due to lag is introduced in a rapidly rising temperature curve.

A5.2.2 The importance of this test method is greatest under vacuum conditions when the heat content of the vapors is minimal.

A5.3 Procedure

A5.3.1 Arrange a 1 L beaker of water on a hot plate with a glass thermowell supported vertically in the water. Maintain the temperature of the water at $90\text{ }^{\circ}\text{C} \pm 5\text{ }^{\circ}\text{C}$.

A5.3.2 Correct the sensor to an instrument, preferably with a digital readout, with readability to $0.1\text{ }^{\circ}\text{C}$. Alternatively,

connect the sensor to a strip chart recorder of suitable range allowing interpolation to $0.1\text{ }^{\circ}\text{C}$. Set the chart speed at 30 cm/h for readability.

A5.3.3 Insert the sensor into a hole in the center of one side of a closed cardboard box about 30 cm on a side. Hold the sensor in place by a friction fit on the joint. Allow the sensor to reach equilibrium temperature. Record the temperature when it becomes stable.

A5.3.4 Remove the sensor and insert it into the heated thermowell in the beaker of water. After the sensor has reached a temperature of $80\text{ }^{\circ}\text{C}$, remove it and immediately insert it into the hole in the box. Note with a stopwatch, or record on the strip chart, the time interval while the sensor cools from $30\text{ }^{\circ}\text{C}$ above to $5\text{ }^{\circ}\text{C}$ above the temperature recorded in A5.3.3.

A5.3.5 A time interval in excess of 175 s is unacceptable.

A5.4 Precision and Bias

A5.4.1 No statement is made concerning either the precision or bias of **Annex A5** for measuring temperature response because the result is used to determine whether there is conformance to the criteria stated in A5.3.5.

A6. PRACTICE FOR CALIBRATION OF SENSORS

A6.1 Principle

A6.1.1 This practice deals with the basic calibration of temperature sensors and vacuum sensors and their associated recording instruments.

A6.1.2 The temperature sensor and its associated instrument are calibrated by observing and recording the temperatures of the melting point and boiling point of pure compounds or eutectic mixtures.

A6.1.3 The vacuum sensor and its associated instrument are calibrated against primary standards, such as the non-tilting McLeod gauge, mercury manometer, or other analogous primary standard pressure devices.

A6.2 Temperature Sensors

A6.2.1 *Apparatus*—A suitable apparatus is shown in **Fig. A6.1**. For the freezing point of water, a Dewar flask filled with crushed ice and water can be substituted. For the boiling point of water, use an equilibrium still or ebulliometer, a tensimeter, or other apparatus for measuring vapor-liquid equilibrium.

A6.2.2 Procedure:

A6.2.2.1 Ensure that approximately 0.5 mL of silicone oil or other inert liquid is in the bottom of the thermowell and insert one or more thermocouples or other sensors connected to their respective measuring instruments.

A6.2.2.2 Heat the melting point bath to a temperature $10\text{ }^{\circ}\text{C}$ above the melting point of the metal inside and hold this temperature at least 5 min to ensure that all of the metal is melted.

A6.2.2.3 Discontinue heat input to the melting point bath and observe and record the cooling curve. When the curve exhibits a plateau of constant temperature for longer than 1 min, the temperature of the recorded plateau is accepted as the calibration temperature. If the freezing plateau is too short, it can be prolonged by employing some heat during the cooling cycle. Alternatively, the melt bath may have become contaminated or excessively oxidized. In this case, replace the metal.

A6.2.2.4 Record the calibration temperature at each of the following points to the nearest $0.1\text{ }^{\circ}\text{C}$:

Material	Temperature, $^{\circ}\text{C}$
Ice	melting point 0.0
Water	boiling point 100.0
Tin: Lead: Cadmium (50:32:18)	melting point 145.0
Sn	melting point 231.9
Pb	melting point 327.4

A6.2.2.5 Set up a correction table by listing the correction to be added algebraically to the observed temperature to give the true temperature at each calibration point. A graphical plot of the above corrections connected by a smooth curve may be helpful in routine use.

A6.3 Vacuum Sensors

A6.3.1 Apparatus:

MELTING POINT BATH FOR TEMPERATURE STANDARDS

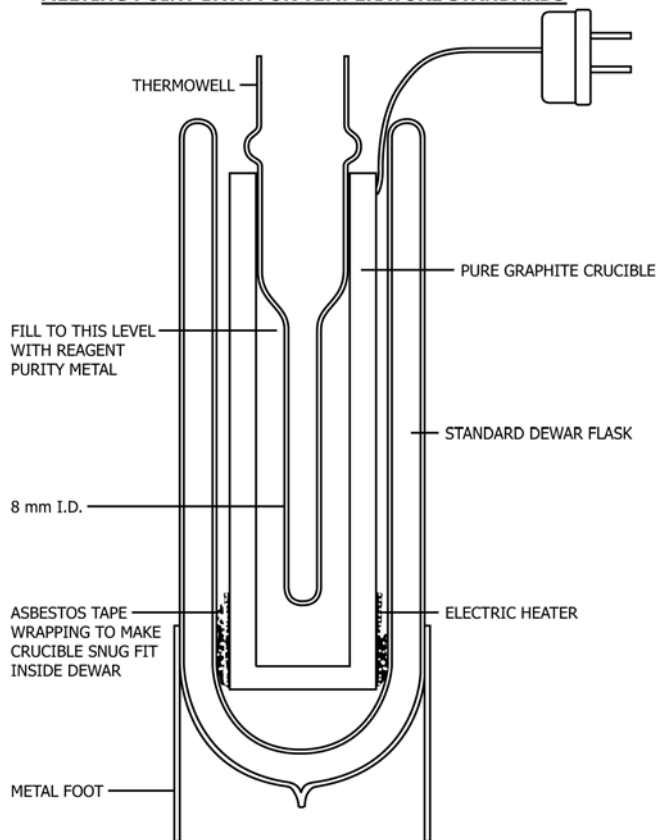

FIG. A6.1 Melting Point Bath for Temperature Standards

A6.3.1.1 Assemble a vacuum manifold such as that shown in Fig. A6.2. It shall be capable of maintaining steady pressures within 1% at all desired levels.

A6.3.1.2 For pressures between atmospheric down to 13.3 kPa (100 mm Hg), an evacuated mercury barometer, manometer, or another analogous primary standard pressure device is the primary reference standard. Fig. A6.3 shows a convenient design in which any internal air above the mercury is trapped in the fine tip at the top where it can be seen at a glance. For a suitably evacuated gauge, there is no air in the tip visible to the unaided eye when vented. The glass shall be chemically clean inside. Other primary standards should be used according to manufacturer’s instructions.

A6.3.1.3 If air can be seen in the tip, clamp the gauge in a horizontal position with the vacuum connection facing upward and the top of the gauge lower than the bottom so as to expose the hole in the bottom of the central tube. Apply a vacuum of less than 0.0133 kPa (0.1 mm Hg) and heat the end of the gauge containing the mercury with an infrared heat lamp or a hot air gun until the mercury comes to its boiling point.

Continue heating slowly until the mercury in the central tube has partly distilled out into the outer tube. Condensed mercury on the wall will be evidence of this. Return the manometer to the vertical position and slowly release the vacuum. Verify that there is no air visible at the tip of the central tube when fully vented. (**Warning**—Mercury vapor is poisonous. Harmful or fatal if inhaled or ingested.)

A6.3.1.4 For pressures below 13.3 kPa, a primary standard, such as the non-tilting McLeod gauge or another primary reference standard, shall be carefully maintained.

A6.3.1.5 Choose a McLeod gauge with a range such that the desired calibration pressure falls between 10 % and 90 % of the scale. Before refilling with clean mercury, heat the empty reference McLeod gauge at 250 °C for at least 30 min at a pressure below 10 Pa (0.075 mm Hg). Thereafter, carefully protect the reference gauge from exposure to moisture such as that from atmospheric air. The use of two reference McLeod gauges of different pressure ranges is recommended as a precaution. If they agree at the test pressure, it is an indication that the system is free of moisture and other condensables.

NOTE A6.1—The general principles of construction of McLeod gauges and other primary reference devices are well established. The dimensions and tolerances of such a gauge are beyond the scope of this test method.

A6.3.1.6 Alternatively, certified secondary gauges, electronic or otherwise, can be used, provided the output can be traced back to a primary standard. Secondary gauges shall be recertified at a regular basis, but at least once a year.

A6.3.2 Procedure:

A6.3.2.1 Set up the test manifold such as that shown in Fig. A6.2. Ensure that the test manifold is leak-free and can be maintained at a steady pressure at the required level. A suitable leak test is to pump down to a pressure below 0.1 kPa and isolate the pump. Observe the pressure inside the unit for at least 1 min. If the pressure rises no more than 0.01 kPa in that period, the apparatus is considered acceptable.

A6.3.2.2 Connect the reference (primary) vacuum gauge(s) and the gauge(s) to be calibrated to the manifold. The gauges shall have such a range that the desired calibration pressure falls between 10 % and 90 % of the scale. Insert a dry ice trap between the manifold and the vacuum pump. Adjust the pressure to the required level for the test and run a final leak test as above.

A6.3.2.3 After steady conditions have been maintained for at least 3 min, readings are made of all gauges and compared with the reference gauge.

A6.3.2.4 Repeat the above procedure at the other required pressure levels.

A6.3.2.5 Make up a chart of corrections to be added at each pressure level for each gauge tested. This can be used for interpolation when necessary.

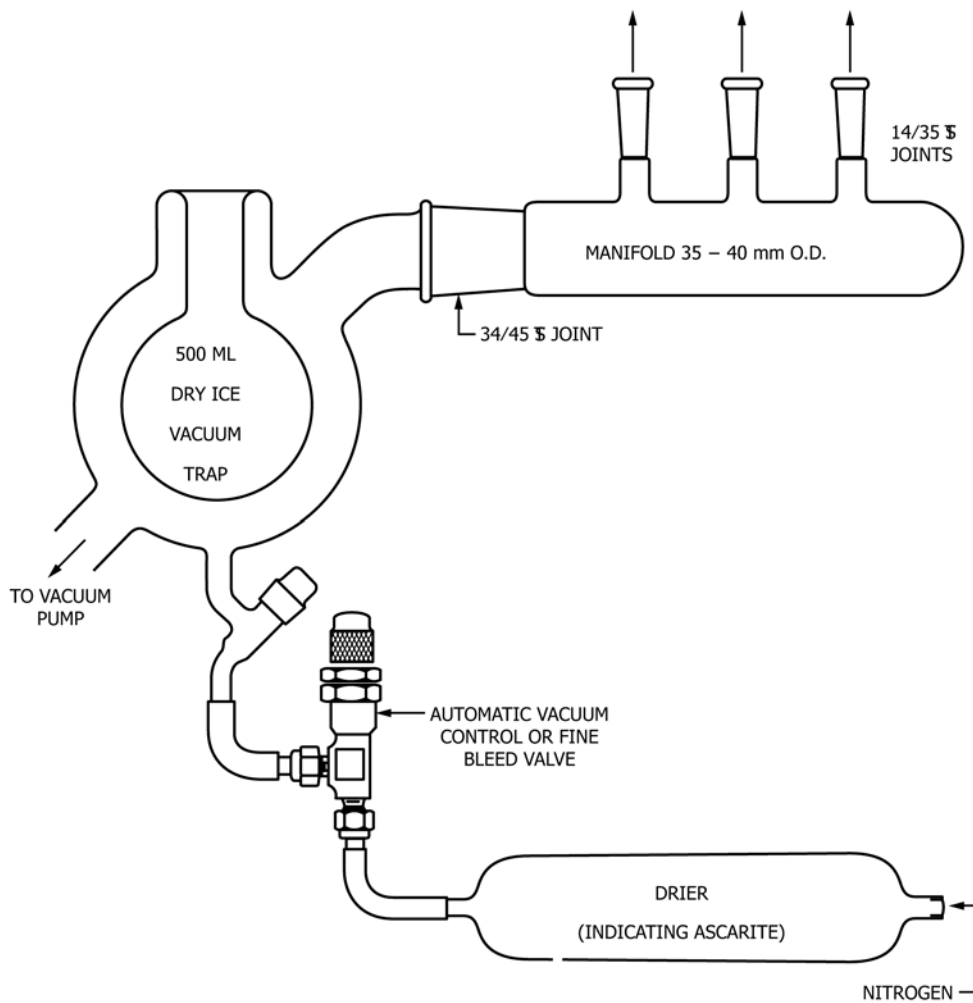

FIG. A6.2 Calibration of Vacuum Gauges

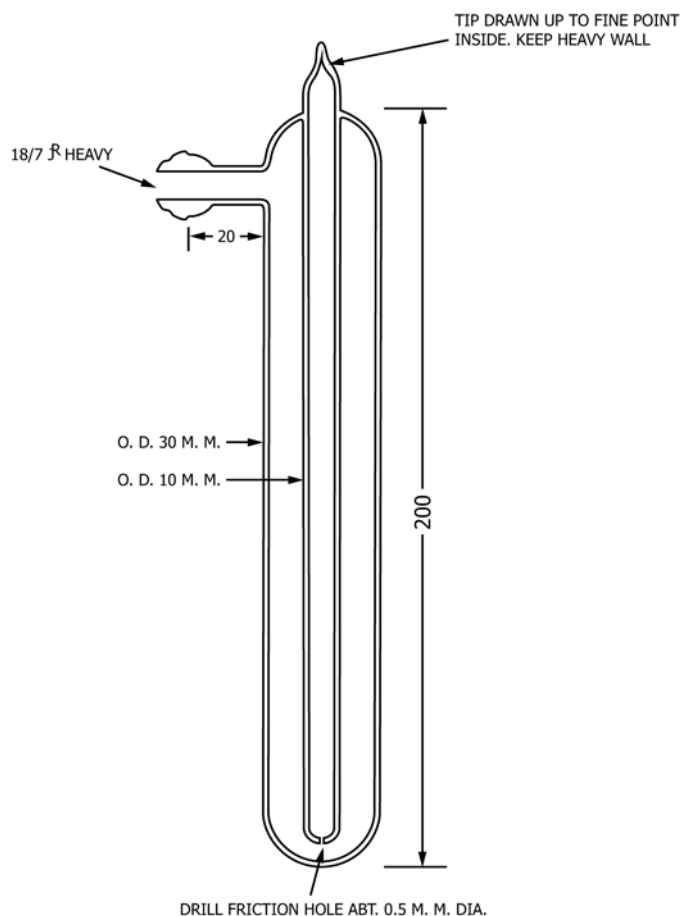

FIG. A6.3 Vacuum Manometer

A7. TEST METHOD FOR VERIFICATION OF REFLUX DIVIDING VALVES

A7.1 Scope

A7.1.1 This test method is for determining whether a liquid reflux dividing valve produces the prescribed reflux ratio.

A7.2 Summary of Test Method

A7.2.1 A hydrocarbon distillate of medium density is introduced to the reflux dividing valve while operating in the normal way. The reflux ratio is determined by the ratio of the two streams so obtained. The test is conducted over a range of rates normally encountered in use to ensure that performance is acceptable at all levels.

A7.3 Significance and Use

A7.3.1 This test method is intended to ensure that the valve in operation actually divides the reflux in the desired ratio.

A7.4 Apparatus

A7.4.1 The apparatus consists of the column and reflux divider with its controller and the condenser if necessary for convenient entry of liquid to the divider.

A7.4.2 A means must be provided for introducing the test liquid at steady rates over a range that includes 10 % to 90 % of the maximum capacity of the column under test. This apparatus can be a pumping system, but a simple gravity flow system can be used if its reservoir is of a capacity that will ensure relatively uniform rates for each test. A supply of 400 mL beakers tared to the nearest gram and a stopwatch are also required.

A7.5 Reagents and Materials

A7.5.1 The test liquid can be any hydrocarbon fraction in the kerosine to diesel oil range (from 150 °C to 300 °C).

A7.6 Preparation of Apparatus

A7.6.1 Assemble the column in the normal way with the valve in place. Attach the condenser in its normal position if this will facilitate the introduction of the test liquid to the divider. Connect the control device to the liquid dividing valve.

A7.6.2 Set an untared beaker of suitable size under the bottom of the column and another under the takeoff point.

A7.6.3 Mount the liquid flow system so that the necessary range of flow rates can be provided.

A7.7 Procedure

A7.7.1 Start the valve and set the control device in such a way that the valve is open for not less than 4 s and not more than 6 s, and closed for a period that is five times as long (5:1 ratio).

A7.7.2 Commence introduction of the test liquid to the valve at a rate equal to about 10 % of the maximum boilup rate for the column under test.

A7.7.3 After 2 min have elapsed, simultaneously replace the beakers under the column and under the takeoff point with tared beakers.

A7.7.4 At precise 5 min intervals, simultaneously replace those beakers with another pair of tared beakers. After three sets of tared beakers have been collected, return the untared beakers and shut off the flow of liquid.

A7.7.5 Weigh each of the tared beakers and obtain the mass of liquid in each to the nearest gram.

A7.7.6 Calculate the ratio of the mass of test liquid recovered in the beaker at the bottom of the column to that at the top of the column in each of the three 5 min tests.

A7.7.7 If the ratios so obtained are not consistent to within $\pm 5\%$, repeat A7.7.1 – A7.7.6.

A7.7.8 Repeat the sequence A7.7.1 – A7.7.7 at flow rates equal to about 30 %, 60 %, and 90 % of the maximum boilup rates for the column under test.

A7.7.9 Repeat sequence A7.7.1 – A7.7.7 for a valve operation in which the closed portion of the cycle is equal to two times the open period (2:1 ratio).

A7.7.10 When the actual reflux ratio differs by more than 10 % from the desired ratio, the valve is not acceptable and must be corrected. Fig. A7.1 illustrates graphically the test results of a typical valve of acceptable performance.

A7.8 Precision and Bias

A7.8.1 No statement is made concerning either the precision or bias of Annex A7 for checking the location of the temperature sensor because the result is used to determine whether there is conformance to the criteria stated in A7.7.10.

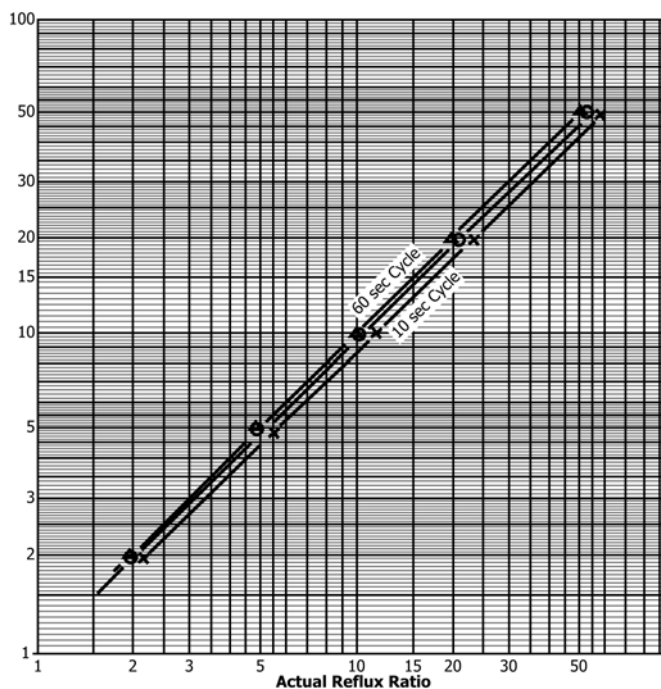

FIG. A7.1 Graphical Illustration of Actual Reflux Ratio of a Typical Reflux Divider

A8. PRACTICE FOR CONVERSION OF OBSERVED VAPOR TEMPERATURE TO ATMOSPHERIC EQUIVALENT TEMPERATURE (AET)

A8.1 Scope

A8.1.1 This practice is for conversion of the actual distillation temperature obtained at sub-ambient pressure to AET corresponding to the equivalent boiling point at atmospheric pressure, 101.3 kPa (760 mm Hg), by means of equations derived by Maxwell and Bonnell.⁹

A8.2 Significance and Use

A8.2.1 Final data on atmospheric equivalent temperatures are to be obtained by computation.

A8.3 Calculation

A8.3.1 Convert observed vapor temperature to atmospheric equivalent temperature using Eq A8.1:

$$AET = \frac{748.1A}{[1/(T+273.15)]+0.3861A - 0.00051606} - 273.15 \quad (A8.1)$$

where:

AET = atmospheric equivalent temperature, °C, and
T = observed vapor temperature, °C.

A8.3.1.1 Calculate A using Eq A8.2 or Eq A8.3:

⁹ Maxwell and Bonnell, *Industrial Engineering Chemistry*, Vol 49, 1957, p. 1187.

$$A = \frac{5.143222 - 0.972546 \log_{10} P}{2579.329 - 95.76 \log_{10} P} \quad (A8.2)$$

where:

P = operating pressure, kPa, (operating pressure ≥ 0.266 kPa), or

$$A = \frac{5.994295 - 0.972546 \log_{10} P}{2663.129 - 95.76 \log_{10} P} \quad (A8.3)$$

where:

P = operating pressure, mm Hg (operating pressure ≥ 2 mm Hg).

A8.3.2 The equations are correct only for fractions that have a Watson K -factor of 12.0 ± 0.2 . The K -factor shall be assumed to be 12 and any effect of K -factor ignored unless there is mutual agreement to the contrary.

A8.3.3 If correction is required, calculate the K -factor using Eq A8.4:

$$K = \frac{\sqrt[3]{1.8(B+273.15)}}{D} \quad (A8.4)$$

where:

B = mean average boiling point, °C, and

D = relative density at 15.6/15.6 °C.

A8.3.3.1 By custom, either the mid vapor temperature of the fraction or the midpoint of a gas chromatographic distillation of the fraction can be used for the mean average boiling point. In either case the method must be specified.

A8.3.3.2 An estimate of the K -factor can be made using Fig. A8.1.

A8.3.4 Calculate the correction to be applied to the AET using Eq A8.5:

$$t = -1.4[K - 12] \left[\log_{10} \left(\frac{P_a}{P_o} \right) \right] \quad (A8.5)$$

where:

t = correction, °C

P_a = atmospheric pressure, kPa (mm Hg), and

P_o = observed pressure, kPa (mm Hg).

A8.3.4.1 An estimate of the correction can be made using Fig. A8.2.

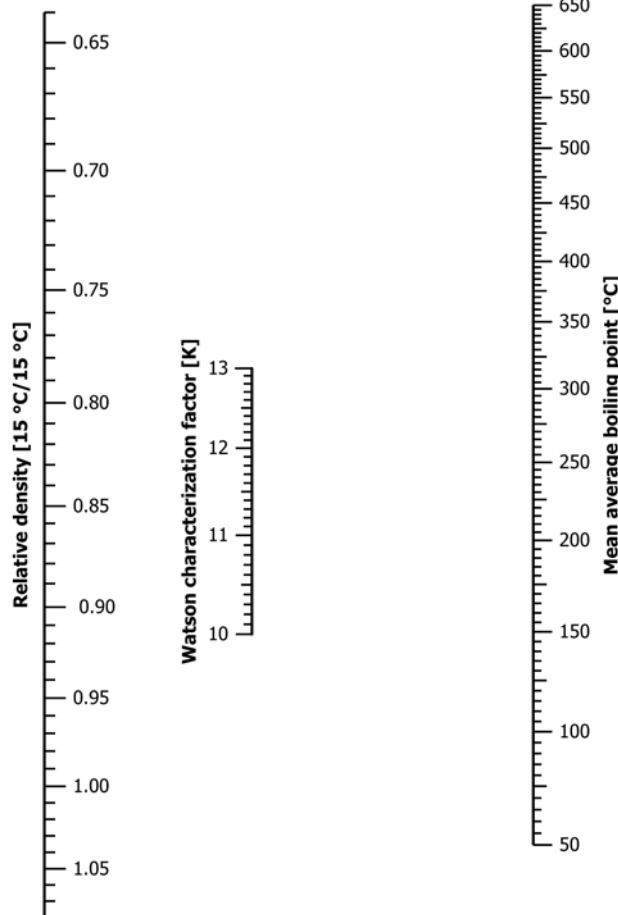

FIG. A8.1 Watson Characterization Factor of Petroleum Fractions

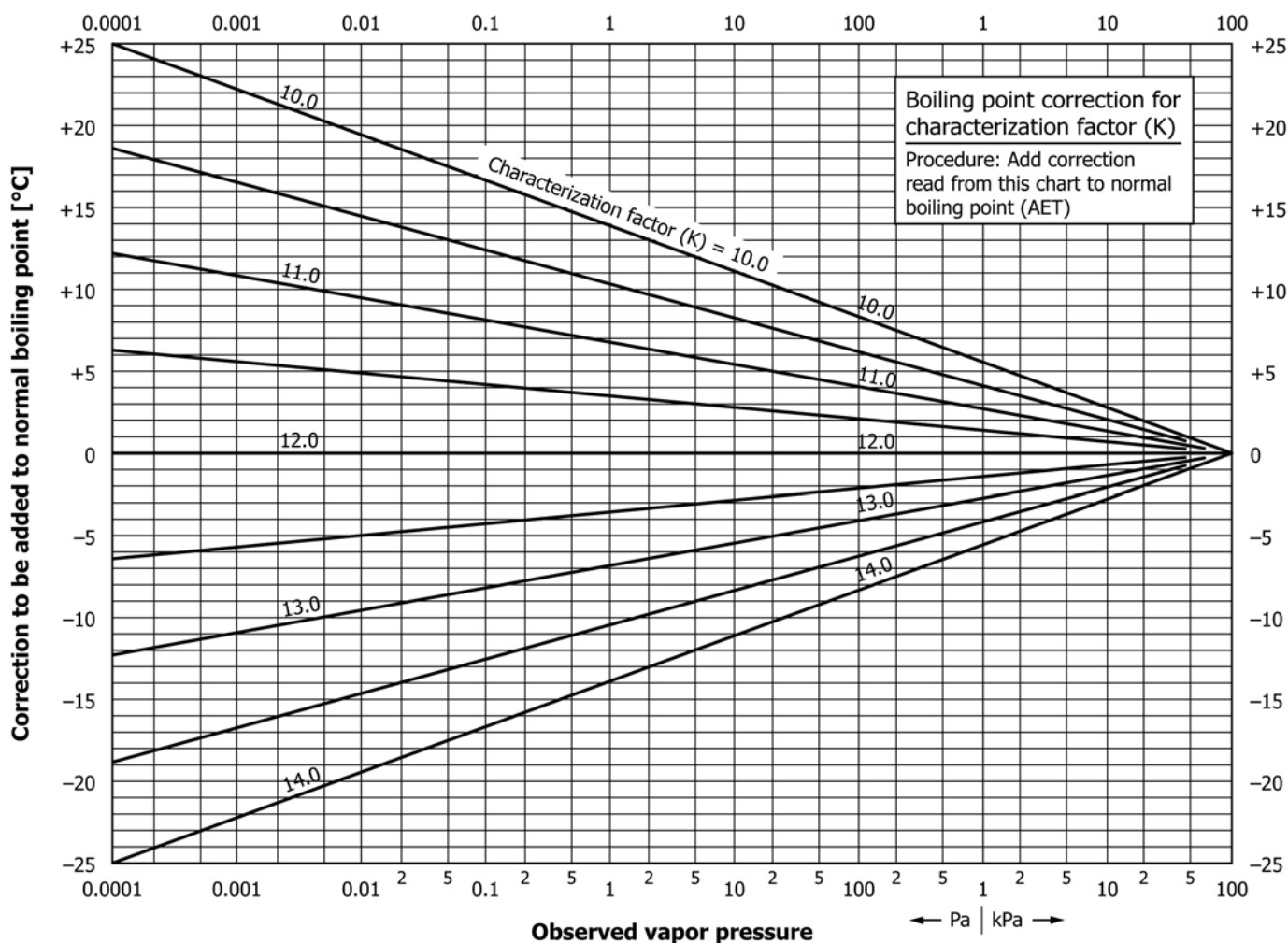

FIG. A8.2 Boiling Point Corrections for K-Factor

APPENDIXES

(Nonmandatory Information)

X1. PRACTICE FOR DEHYDRATION OF A SAMPLE OF WET CRUDE OIL

X1.1 Scope

X1.1.1 This practice is for dehydrating a sample of wet crude oil prior to fractional distillation.

X1.2 Summary of Practice

X1.2.1 A sufficient quantity of the sample is distilled in a low-efficiency column under atmospheric pressure at zero reflux ratio (total takeoff) to 130 °C, the water decanted, and dry components recombined.

X1.3 Significance and Use

X1.3.1 Dehydration is important in order to achieve accurate yields in the light naphtha region.

X1.4 Apparatus

X1.4.1 The dehydration of a sample of wet crude oil requires apparatus, such as that shown in Fig. 1, composed of:

X1.4.1.1 *Distillation Flask*, with two side arms. In place of the differential pressure manometer in the second sidearm, a capillary is fitted for the passage of nitrogen into the liquid. When a sample is suspected of containing emulsified water or significant amounts of clay or sediment, or both, additional risk to glass apparatus is involved. In this case, remove gross water and sediment and use a metal flask for dewatering.

X1.4.1.2 *Distillation Column*, shall be of the type described in 6.1.3.

X1.4.1.3 The rest of the apparatus is identical to that described in 6.1.

X1.5 Preparation of Apparatus

X1.5.1 Clean the distillation column and all the glassware before starting the test.

X1.6 Procedure

X1.6.1 Cool the charge to a temperature not lower than 0 °C. Decant any bulk water that may be present. Weigh by difference to the nearest gram, into a chilled distillation flask containing some pieces of glass or porcelain, a given volume of wet crude oil.

X1.6.2 Attach the flask to the column and pass a slow stream of nitrogen (8 cm³/s) through the capillary. Vent the condenser through two traps in series maintained at the temperature of dry ice. Circulate coolant at a temperature of –20 °C in the condensers.

X1.6.3 Apply heat to the flask, regulating it to attain a moderate reflux rate as specified in 10.2.4 – 10.2.8 for debutanization. Remove distillate slowly at total takeoff (reflux ratio = 0) until a vapor temperature of 130 °C is reached. Collect the fraction distilling below 65 °C in a receiver cooled to –20 °C or lower.

X1.6.4 Shut off the reflux valve and the heating system. Cool the flask and contents to ambient temperature. Maintain the traps at the temperature of dry ice. Weigh the distillate fractions obtained.

X1.6.5 To separate the water from each distillate fraction, cool to –5 °C and decant the hydrocarbon liquid. Weigh the water.

X1.6.6 Remove the condenser and rinse it with alcohol or acetone to remove adhering drops of water. Dry with air and replace it.

X1.6.7 Recombine the cooled decanted fractions with the distillation residue observing the usual precautions against losses. Do not recombine the trap fraction.

X1.6.8 Record the quantity of dry oil recovered. If reblending of the dried fractions was done in the original flask, this flask can be used for subsequent distillation.

X1.7 Calculation

X1.7.1 Calculate the mass % of water using Eq X1.1.

$$W = 100(A/B) \quad (X1.1)$$

where:

A = mass of water recovered, g,

B = mass of charge, g,

W = mass % of water, and

100 = percentage constant.

X1.8 Precision and Bias

X1.8.1 No statement is made concerning either the precision or bias of Appendix X1 for mass % water because the test method is used primarily for sample preparation for Test Method D2892.

X2. PRACTICE FOR PERFORMANCE CHECK

X2.1 Scope

X2.1.1 This practice covers a procedure for calculating column performance from GC boiling point distributions on fractions and residues, obtained by distilling an average (30 to 40 API-gravity) crude oil under actual Test Method D2892 distillation conditions.

NOTE X2.1—There are no theoretical reasons to limit the API-gravity range from 30 to 40. However, the use of a crude oil in the quoted range will, more or less, ensure that sufficient product is available to assess performance, both at the upper and lower end of the temperature scale. The use of heavier crudes may not yield sufficient quantities at the low end, while the reverse is true for lighter crudes.

X2.1.2 The assessment of column performance can be made at any cut point where samples of two adjacent fractions or a residue can be analyzed by gas chromatography. Either fresh or stored samples can be analyzed, as long as they have been protected from loss by evaporation. Recommendations are given for the number and spacing of cut points to be analyzed for performance.

X2.1.3 A precise mathematical method¹⁰ for the calculation of distillation efficiency of multi-component mixtures is de-

scribed and is recommended. For convenience sake, a simple graphical solution based on the same method is also included.

X2.1.4 Overall column performance is assessed in terms of column efficiency (minimum tray number) and in terms of the differential between the nominal cut point (AET) and the calculated effective cut point (ECP). Criteria are given for acceptance of column performance. Possible corrective action(s), if required, are also indicated.

X2.2 Significance and Use

X2.2.1 Good agreement in yield of fractions can be achieved under a variety of conditions because efficiency has no measurable effect on fraction yields except for very low efficiencies and at the beginning and end of a distillation. However, fractions produced at high efficiency will have a narrower boiling range and hence some different properties than the same fraction made at low efficiency. To arrive at a standard level of efficiency and standard fraction quality, an overall check is recommended to assess the actual performance of the system. If the results of this test (Appendix X2) are unacceptable, then the basic performance determinations as outlined in Annex A1 – Annex A5 inclusive and Annex A7 should be considered to determine the cause. The results of the

¹⁰ Butler and Pasternak, *The Canadian Journal of Chemical Engineering*, Vol 42, 1964, p. 47.

overall performance check as described in this appendix provides clues for possible causes and corrective actions in such a case.

X2.3 Summary of Practice

X2.3.1 The distribution of (pseudo) components between the overlapping tail and front of two adjacent fractions (or a residue) is calculated from GC analysis. The linearized transform of the distribution coefficient is plotted against the boiling point of the (pseudo) component. By linear regression, the best possible straight line is obtained. The efficiency is calculated from the slope of the line by means of a modified Fenske equation. The ECP is defined as the temperature at which the overlaps are equal on the basis of mass-percent of the charge, or in mathematical terms, the temperature at which the distribution coefficient equals 0.5. This form of the efficiency calculation is mathematically identical to the graphical procedure described by Butler and Pasternak.

X2.4 Procedure

X2.4.1 Obtain samples of contiguous fractions or a residue for each level of pressure and analyze them according to an appropriate boiling point distribution method. The fractions shall be wide enough so that the overlap by GC analysis does not extend beyond the fraction. Uniform 25 °C wide fractions are recommended, but wider fractions can be employed without deterioration of the reliability of the assessment. The recommended number of fractions to be obtained and the spacing of the cut points is discussed in X2.6. The range of application of the available boiling point distribution GC test methods, together with the recommended application to cuts by Test Method D2892 is listed in X2.4.1.1 – X2.4.1.3. Although adjacent fractions may be analyzed by different test methods, it is highly recommended that adjacent fractions be analyzed by the same test method.

NOTE X2.2—Different GC boiling range test methods might show relative bias towards each other. If such a bias exists it will affect the slope of the regression line and, therefore, could lead to misleading efficiency results.

X2.4.1.1 *Fractions – Cut Point ≤150 °C*—Analyze by Test Method D3710. The final boiling point of the fraction >150 °C should not exceed 260 °C. Alternatively, Test Method D5134 can be used. In the latter case it can only be applied to cuts ≤100 °C. If Test Method D5134 is used, the distribution coefficients are calculated for well-defined and separated individual compounds. Any number of compounds can be used, with a minimum of four. Aromatic compounds shall not be used for efficiency calculations.

NOTE X2.3—Due to azeotropic effects, aromatic compounds will not fall on the same straight line as aliphatic compounds with the same boiling point.

X2.4.1.2 *Fractions – Cut Point >100 °C*—Analyze by Test Method D2887.

X2.4.1.3 *Residues (FBP >538 °C)*—Presently there are no standardized methods for the characterization of the boiling point distribution of residues on the books. However, methods for residue containing materials are under development (see Note X2.3). For the time being, in-house methods can be used

provided that they are based on the same principles of boiling point separation and calibration, that is, employ a methylsilicone column and retention times calibrated for boiling point by paraffins with boiling points assigned as given in Test Method D2887.

NOTE X2.4—A high-temperature SIMDIST method is still under development by ASTM D02.04.H and in its present draft is only applicable to petroleum distillates. However, the methodology is widely used in the industry to measure the boiling range distribution of residues as well. Hence, it is envisaged that at a later date residues will be included in the scope of this proposed test method.

X2.4.2 Using the results of the GC analyses of two consecutive distillate fractions, formulate groups defined by equally spaced temperature ranges (pseudo components). The groups shall be formed such that the temperature range of the first group and that of the last group bracket the overlapping portions of the distillate fractions. For each group (pseudo component) list the noncumulative yields (% M/M on whole fraction, referred to as *Yield o.f.*) contained within that temperature range in each fraction. The temperature range used should have a width not smaller than 5 °C nor wider than 15 °C. The GC slices of adjacent distillate cuts by Test Method D2892 shall have the same start and end boiling point temperature. To ensure sufficient accuracy, within the constraint of fraction width, at least four non-outlying components should be identifiable with a distribution factor ≥0.05 and ≤0.95 (see X2.5.1).

X2.4.3 Calculate the yield of the (pseudo) components in % M/M on the original (Test Method D2892) charge mass:

$$Yield\ o.c. = Yield\ o.f. \times \frac{\text{mass fraction, g}}{\text{mass charge, g}} \quad (X2.1)$$

X2.4.3.1 Assign a boiling point to each (pseudo) component exactly halfway the start and end boiling point temperature of the (pseudo) component.

NOTE X2.5—If actual components as obtained by Test Method D5134 are used in the calculations, assign a boiling point as obtained from literature for that component.

X2.5 Calculation

X2.5.1 Calculate the distribution coefficient (*D*) for each (pseudo) component by means of the following equation:

$$D_i = \frac{Y1_i}{(Y1_i + Y2_i)} \quad (X2.2)$$

where:

$Y1_i$ = yield (% M/M on charge) of (pseudo) component *i* in Fraction 1, and

$Y2_i$ = yield (% M/M on charge) of (pseudo) component *i* in Fraction 2.

X2.5.2 Calculate the coefficients of the following equation:

$$T = aX + b \quad (X2.3)$$

from:

$$a = \frac{\sum T_i X_i - (\sum T_i \sum X_i / n)}{\sum T_i^2 - ((\sum T_i)^2 / n)} \quad (X2.4)$$

and:

$$b = \sum X_i/n - a(\sum T_i/n) \quad (\text{X2.5})$$

where:

n = number of (pseudo) components, and
 T_i = boiling point of (pseudo) component, °C.

and:

$$X_i = \log_{10} \left(\frac{D_i}{1 - D_i} \right)$$

X2.5.3 By definition, the ECP is the temperature where $D_i = 0.5$, hence $X_i = 0$ thus $ECP = b$.

X2.5.4 The efficiency is calculated from:

$$N = \frac{X \times (T_i + 273.15)}{4.6 \times (T_c - T_b)} \quad (\text{X2.6})$$

where:

N = efficiency,
 X = $\log_{10} \left(\frac{D_x}{1 - D_x} \right)$ of reference component,

T_i = average tower temperature, °C,

T_c = cut point temperature, °C, and

T_b = boiling point of reference component, °C.

X2.5.4.1 As a reference compound any (pseudo) component can be chosen in the boiling range overlap of the two adjacent fractions, except a component whose boiling point (T_b) is equivalent to the ECP. Subsequently, the corresponding X is calculated from Eq X2.5.

X2.5.4.2 For cuts obtained under atmospheric conditions and to obtain the actual tray number use the following temperatures:

$$T_c = ECP = AET, \text{ °C, and}$$

$$T_t = \text{actual (nominal) cut point, °C.}$$

X2.5.4.3 For cuts obtained under reduced pressure and for obtaining the column efficiency (N_{minimum}) for comparative purposes, the actual column temperature shall be used. In this case the tower temperature T_t shall be considered equivalent to the actual vapor temperature at the nominal cutpoint (AET) under the pressure condition prevailing at the nominal cut point.

X2.5.5 Example of efficiency calculation for cuts obtained under atmospheric conditions.

Excerpt of Test Method D2892 Analysis:

Operating pressure = 101.3 kPa

Nominal cut point (AET) = 200 °C

Actual cut point = 200 °C

Yield % M/M on charge; Fraction 1 (<200 °C) = 8.5

Yield % M/M on charge; Fraction 2 (>200 °C) = 9.0

X2.5.5.1 Linear regression of X_i versus T_i (X2.5.2):

$$T = -17.32X + 199.9 \text{ thus } ECP = 199.9 \text{ °C}$$

X2.5.5.2 Taking as a reference component a component with a boiling point $T = 180 \text{ °C}$ ($T_b = 180 \text{ °C}$) and substituting this in the derived equation the corresponding $X = 1.1503$. Furthermore, $T_i = 200 \text{ °C}$. Substituting these numbers in Eq X2.7 will yield an efficiency of $N = 5.9$; or $N_{\text{actual}} = N_{\text{minimum}} = 5.9$.

X2.5.6 Example of efficiency calculation for cuts obtained under subatmospheric conditions.

Excerpt of Test Method D2892 analysis:

Operating pressure = 13.3 kPa

Nominal cut point (AET) = 300 °C

Actual cut temperature = 221.4 °C (from Annex A8)

Yield % M/M on charge; Fraction 1 (<200 °C) = 10.3

Yield % M/M on charge; Fraction 2 (>200 °C) = 9.8

X2.5.6.1 Linear regression of X_i versus T_i (X2.5.2):

$$T = -14.77X + 300.1 \text{ thus: } ECP = 300.1 \text{ °C}$$

X2.5.6.2 Taking as a reference component a component with a boiling point $T = 280 \text{ °C}$ ($T_b = 280 \text{ °C}$) and substituting this in the derived equation with the corresponding $X = 1.3605$.

X2.5.6.3 For the actual efficiency $T_i = 300 \text{ °C}$. For the minimum efficiency (corrected for pressure) $T_i = 221.4 \text{ °C}$. Substituting these numbers in Eq X2.5 will yield an actual efficiency $N_{\text{actual}} = 8.4$ and a minimum efficiency of $N_{\text{minimum}} = 7.3$.

X2.5.7 Graphical Solution:

X2.5.7.1 A graphical solution to Eq X2.2 is shown in Fig. X2.1. On Chart A percent to bottoms is plotted against the boiling point (BP) of the (pseudo) component. The best possible straight line is drawn through the points and extended down through Chart B.

X2.5.7.2 From Chart A, the boiling point corresponding with the intersection of the line with 50 % to bottoms line is read. This is the ECP.

X2.5.7.3 From the intersection of the line on Chart B with the curved line for temperature denoting the ECP, the efficiency N_{actual} can be read from the vertical axis. For atmospheric distillations the minimum efficiency, N_{minimum} , is equivalent to the actual efficiency, N_{actual} . For distillations at subatmospheric pressure, the minimum efficiency can be calculated from the following equation:

$$N_{\text{minimum}} = N_{\text{actual}} \times \frac{T_i + 273.15}{T_n + 273.15} \quad (\text{X2.7})$$

where:

T_t = actual cut point, °C, and

T_n = nominal cut point, °C.

X2.5.7.4 Examples—The same basic data as for the examples in X2.5.5 and X2.5.6 are used. Percent to bottoms is just another way of expressing the distribution coefficient and is related to the distribution coefficient by:

$$\text{Percent to bottoms} = (1 - D_i) \times 100$$

(1) For convenience sake the relevant values for the graphical solution are given in Table X2.3.

X2.5.8 Outliers—Because of inaccuracies in the GC data, especially at the beginning and end of the (GC) distillation curve, it is not unusual to observe outlying points for distribution coefficients <0.05 and >0.95, therefore, it is recommended to inspect the linear plot of T versus X for outliers. The same holds for the graphical solution, but there outliers will be readily observed. If outliers occur they should be removed, because of their very pronounced effect on the slope of the line and hence the value for N . Another cause for significant scatter in data points can be incorrect sample size (too small) with respect to column diameter or dynamic hold-up, or both. Check Table 1 or Annex A2, or both, for correct sample size.

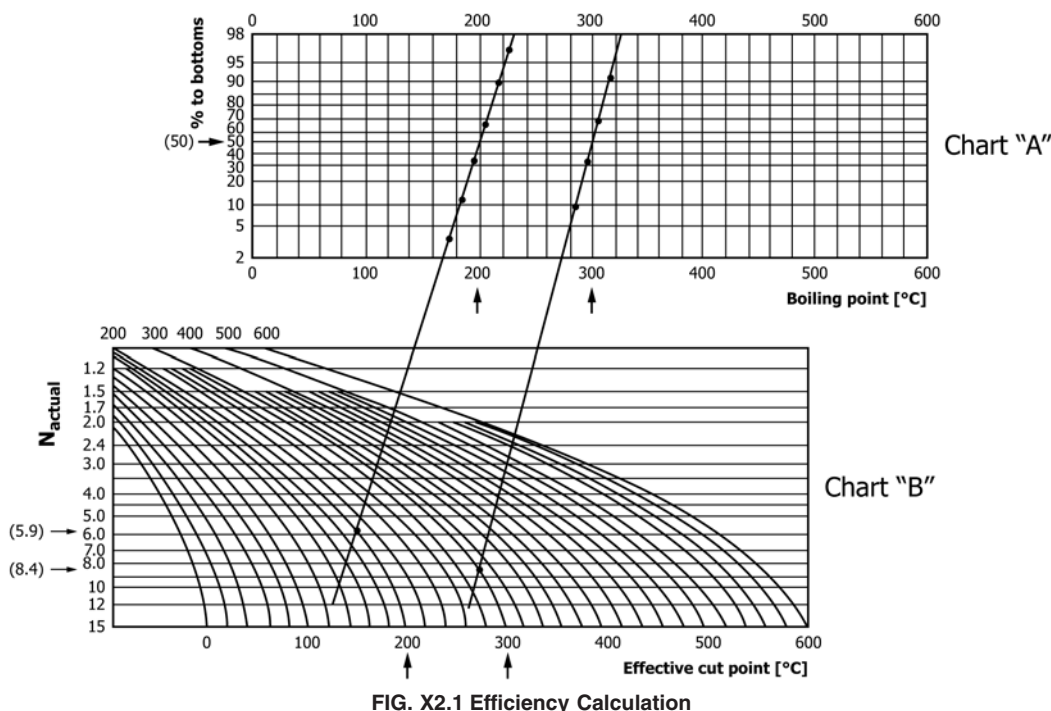

TABLE X2.1 Relevant Values for Calculation Method of Efficiency

NOTE 1—Excerpts from GC analysis (X2.4.2), calculation of distribution coefficient (X2.5.1), and X_i (X2.5.2) where Yield o.f. is % M/M of the component on the fraction (GC result from analysis of the fraction).

Component	BP T_i °C	Fraction 1		Fraction 2		D_i	X_i
		Yield o.f.	Yield o.c. $Y1_i$	Yield o.f.	Yield o.c. $Y2_i$		
160-170	165	19.75	1.68	0.21	0.02	0.989	1.9485
170-180	175	19.40	1.65	0.62	0.06	0.967	1.4706
180-190	185	17.95	1.53	2.03	0.18	0.893	0.9217
190-200	195	13.04	1.11	6.39	0.58	0.658	0.2850
200-210	205	6.96	0.59	12.52	1.13	0.344	-0.2798
210-220	215	2.05	0.17	16.67	1.50	0.104	-0.9350
220-230	225	0.77	0.07	18.45	1.66	0.038	-1.4043
230-240	235	0.18	0.02	18.72	1.68	0.009	-2.0419

TABLE X2.2 Relevant Values for Calculation Method of Efficiency

NOTE 1—Excerpts from GC analysis (X2.4.2), calculation of distribution coefficient (X2.5.1), and X_i (X2.5.2) where Yield o.f. is % M/M of the component on the fraction (GC result from analysis of the fraction).

Component	BP T_i °C	Fraction 1		Fraction 2		D_i	X_i
		Yield o.f.	Yield o.c. $Y1_i$	Yield o.f.	Yield o.c. $Y2_i$		
260-270	265	16.43	1.69	0.08	0.01	0.995	2.3342
270-280	275	16.26	1.67	0.27	0.03	0.984	1.8014
280-290	285	15.00	1.55	1.58	0.15	0.909	0.9991
290-300	295	11.07	1.14	5.92	0.58	0.663	0.2934
300-310	305	5.23	0.54	11.85	1.16	0.317	-0.3336
310-320	315	1.50	0.15	15.77	1.55	0.091	-1.0001
320-330	325	0.30	0.03	16.98	1.66	0.018	-1.7312
330-340	335	0.08	0.01	17.27	1.69	0.005	-2.3126

Inaccuracies in the GC data can be especially pronounced in cuts with very narrow boiling ranges. This is especially evident in lighter boiling cuts (<100 °C). Appropriate attention to skew

(column overloading) and linearity of signal (detector overloading) is advisable if unusual GC results are detected. If using Test Method D3710, note that results are typically

TABLE X2.3 Relevant Values for Graphical Solution

NOTE 1—From Chart A for Example 1, an ECP of 200 °C is read and for Example 2 an ECP of 300 °C. From Chart B for Example 1, the efficiency $N_{\text{actual}} = 5.9$ and for Example 2 $N_{\text{actual}} = 8.4$. For Example 1, atmospheric distillation, $N_{\text{actual}} = N_{\text{minimum}} = 5.9$. For Example 2, subatmospheric distillation, N_{minimum} is derived from Eq X2.7, and amounts to 7.2.

BP	Example 1		Example 2		
	D_j	% to bottom	BP	D_j	% to bottom
165	0.989	1.0	265	0.995	0.5
175	0.967	3.0	275	0.984	1.6
185	0.893	10.7	285	0.909	9.1
195	0.658	34.2	295	0.663	33.7
205	0.344	65.6	305	0.317	68.3
215	0.104	89.6	315	0.091	90.9
225	0.038	96.2	325	0.018	98.2
235	0.009	99.1	335	0.005	99.5

calculated in liquid volume %, not mass % as in the other methods mentioned in X2.1.4. Ensure that correct units are compared (that is, obtain Test Method D3710 results in mass percent).

X2.5.9 Final Calculation:

X2.5.9.1 Calculate the efficiency N_{minimum} and ECP (°C) at each point. Calculate the difference between ECP and AET for each cut point.

X2.5.9.2 Table X2.4 defines the standard efficiency performance of a Test Method D2892 TBP (15/5) distillation, including the standard spread for individual data points. Fig. X2.2 is a graphical presentation of the standard efficiency and the acceptable upper and lower limits of Test Method D2892 column efficiency performance (14 to 18 theoretical plates). A discussion on the acceptability of deviations, probable causes and corrective actions is given in the next chapter.

X2.6 Frequency of Test and Data Interpretation

X2.6.1 It is recommended to carry out a full performance check at the first time of commissioning or any other point of time when there are significant changes to the equipment. After that, a shortened evaluation may be satisfactory, if carried out at regular intervals, for example, once or twice a year, to verify that the equipment is still performing satisfactory.

X2.6.2 Full Performance Check—Determine the ECP and the efficiency N_{minimum} for at least two, but if possibly three, cut points at each of the three most frequently used pressure

TABLE X2.4 Standard Efficiency for 15/5, Test Method D2892 Columns

NOTE 1—The data from Table X2.4 were estimated from the efficiency results obtained as a spin off of a round robin carried out in 1978 on a crude oil with an API-gravity of 35. However, the lack of detailed documentation of these results prevents rigid statistical treatment.

Cut Point, °C	Standard Efficiency, N_{minimum}
50	4.1 ± 0.5
100	4.7 ± 0.6
150	5.3 ± 0.6
200	5.9 ± 0.7
250	6.6 ± 0.8
300	7.2 ± 0.9
350	7.8 ± 0.9

levels. One of the cut points should be the maximum cut point (AET) usually obtained at the appropriate pressure level and one of the cut points should be obtained at the lower end of the temperature range usually covered at the appropriate pressure level. Table X2.5 gives an example of such a scheme.

X2.6.2.1 Only three pressure levels are permitted in Test Method D2892. Distillation at 0.266 kPa provides an alternative to distillation under 1.33 kPa, but both pressure levels shall not be applied consecutively in the same distillation run. The reflux ratio applied shall be 5:1 in all cases, including distillation at 0.266 kPa.

X2.6.3 Performance Verification—Determine the ECP and the efficiency N_{minimum} at three appropriate pressure levels, but only at the highest cut point usually attained at that pressure level.

X2.6.4 Data Interpretation – Efficiency:

X2.6.4.1 Regression of the efficiency (N_{minimum}) obtained against the AET should indicate a best fit for linear regression and produce a straight line more or less parallel to the lines given in Fig. X2.1. The regression line shall not exceed the upper or lower limits shown in Fig. X2.1. Individual points should be randomly spread along the regression line and be within 0.7 theoretical plates from the regression line. If one point is outside these limits, rerun the appropriate GCs, redo the efficiency calculation, and check again. If this check fails or more than one point fails this criterion, the performance of the column shall be considered suspect. Consult X2.6.4.2 – X2.6.4.4 for possible causes. Take corrective action and repeat the whole procedure, including the distillation (see Note X2.6).

X2.6.4.2 If the regression line is curved, yielding relatively high efficiency (N_{minimum}) values at the lowest pressure level, it is an indication for unacceptable heat loss from the column. Check Annex A3. The reverse is true for an overhead column (see 6.1.3.4).

X2.6.4.3 If the regression line is not parallel and yielding a steeper slope, it is an indication of unacceptable heat loss in the column (check Annex A3). The reverse is true for an overheated column (see 6.1.3.4). Nonparallel regression lines can also be an indication of the application of a non-approved and non suitable packing (see 6.1.3 and Table 1).

X2.6.4.4 If the (parallel) regression line is located outside the upper or lower N_{minimum} limits, or both, the following causes might be applicable.

(1) Efficiency of the packing too high or too low. Check Table 1 or Annex A1, or both. If appropriate, correct the efficiency by adding or subtracting packing material from the column.

(2) Reflux ratio too high or too low. Check Annex A7.

(3) Incorrect distillation rate. Consult 10.3.2 and 10.4.5.

X2.6.4.5 For a (shortened) periodic verification of efficiency, the three values for efficiency (N_{minimum}) obtained shall be located inside the band for the regression line obtained from the full performance check and more or less parallel to that regression line. If one or both criteria are not met, it is an indication that the performance of the column has changed. For possible causes refer to X2.6.4.1 – X2.6.4.4.

NOTE X2.6—It is recognized that the setting of acceptable tolerance

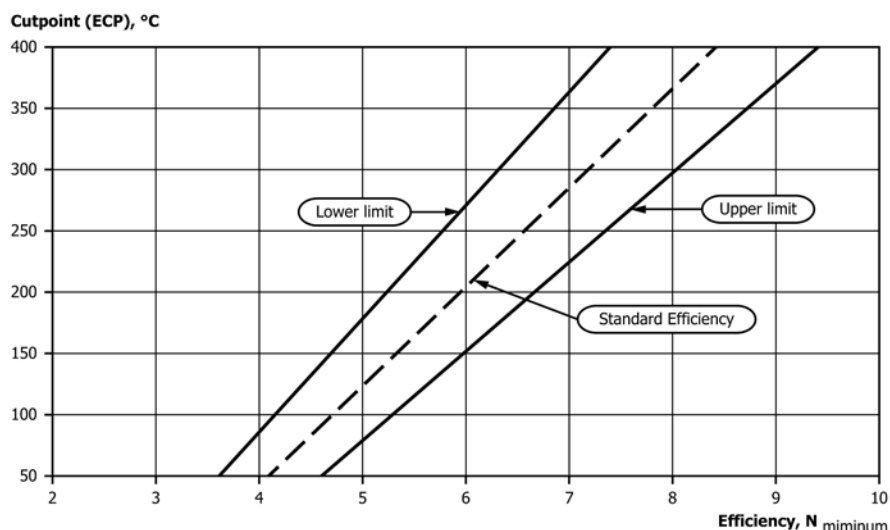

FIG. X2.2 Efficiency Nomograph

TABLE X2.5 Performance Check; Cut Point Scheme

Pressure, kPa	Range for Recommended Cut Point, °C		
	Low	Middle	High
101.3	60 – 70	130 – 140	190 – 200
13.3	230 – 240	260 – 270	290 – 300
1.33	330 – 340	–	360 – 370
0.266	330 – 340	360 – 370	390 – 400

limits to trigger corrective action is the responsibility of the laboratory. However, it is recommended that they do not exceed the limits as indicated.

X2.6.5 Data Interpretation – Cut Point:

X2.6.5.1 When using an average crude oil (30 to 40 API) distilled under TBP (15/5) conditions, it is expected that the difference between ECP and AET will not exceed 0.7 times the reproducibility of the test method. The reproducibility of the test method in degrees Celsius is tentatively estimated for average crude oils to be approximately 8 °C at any pressure level. Therefore, deviations in excess of 6 °C shall be considered suspect (see Note X2.7).

X2.6.5.2 The following causes for excess deviations of ECP from AET can be identified:

(1) If the ECP is consistently and significantly higher or lower than the AET, it is an indication of incorrect temperature measurement. Check Annex A4 – Annex A6.

(2) If the difference between ECP and AET is significantly larger at one or more reduced pressure level(s), it is an indication for incorrect pressure measurement. Check Annex A6.

(3) Incorrect efficiency (too low). Refer to X2.6.4.

(4) Incorrect sample size (too small) with respect to column diameter or dynamic hold-up, or both. Check Table 1 or Annex A2, or both.

(5) Excessive heat loss. Evidence for the latter can also be obtained by careful examination of the *T* versus *X* plot (X2.5.8). In case of excessive heat loss the distribution will be asymmetrical, evidenced by significantly more outlying points at the high end of the temperature scale than at the low end. An overheated mantle (6.1.3.4) will lead to a too low ECP in comparison to the targeted AET.

NOTE X2.7—The setting of acceptable tolerance limits to trigger corrective action is the responsibility of the laboratory. However, the limit given has been proven indicative of incorrect performance in many years of application of Test Method D2892.

NOTE X2.8—Too high efficiency will have no measurable effect on the ECP-AET differential.

SUMMARY OF CHANGES

Subcommittee D02.08 has identified the location of selected changes to this standard since the last issue (D2892 – 17) that may impact the use of this standard. (Approved July 1, 2017.)

(1) Corrected equation references in subsections **X2.5.4.1** and **X2.5.5.2**.

Subcommittee D02.08 has identified the location of selected changes to this standard since the last issue (D2892 – 16) that may impact the use of this standard. (Approved May 1, 2017.)

(1) Corrected **Eq A8.1**, **Eq A8.4**, **Eq X2.6**, and **Eq X2.7**.

Subcommittee D02.08 has identified the location of selected changes to this standard since the last issue (D2892 – 15) that may impact the use of this standard. (Approved Dec. 1, 2016.)

(1) Corrected **Eq X2.7** in **Appendix X2**.

ASTM International takes no position respecting the validity of any patent rights asserted in connection with any item mentioned in this standard. Users of this standard are expressly advised that determination of the validity of any such patent rights, and the risk of infringement of such rights, are entirely their own responsibility.

This standard is subject to revision at any time by the responsible technical committee and must be reviewed every five years and if not revised, either reapproved or withdrawn. Your comments are invited either for revision of this standard or for additional standards and should be addressed to ASTM International Headquarters. Your comments will receive careful consideration at a meeting of the responsible technical committee, which you may attend. If you feel that your comments have not received a fair hearing you should make your views known to the ASTM Committee on Standards, at the address shown below.

This standard is copyrighted by ASTM International, 100 Barr Harbor Drive, PO Box C700, West Conshohocken, PA 19428-2959, United States. Individual reprints (single or multiple copies) of this standard may be obtained by contacting ASTM at the above address or at 610-832-9585 (phone), 610-832-9555 (fax), or service@astm.org (e-mail); or through the ASTM website (www.astm.org). Permission rights to photocopy the standard may also be secured from the Copyright Clearance Center, 222 Rosewood Drive, Danvers, MA 01923, Tel: (978) 646-2600; <http://www.copyright.com/>