



Standard Test Method for Determination of Octane Number of Spark-Ignition Engine Fuels by On-Line Direct Comparison Technique¹

This standard is issued under the fixed designation D2885; the number immediately following the designation indicates the year of original adoption or, in the case of revision, the year of last revision. A number in parentheses indicates the year of last reapproval. A superscript epsilon (ϵ) indicates an editorial change since the last revision or reapproval.

This standard has been approved for use by agencies of the U.S. Department of Defense.

1. Scope*

1.1 This test method covers the quantitative online determination by direct comparison of the difference in knock rating or delta octane number of a stream sample of spark-ignition engine fuel from that of a comparison reference fuel.

1.2 This test method covers the methodology for obtaining an octane number using the measured delta octane number and the octane number of the comparison reference fuel.

1.3 The comparison reference fuel is required to be of essentially the same composition as the stream sample to be analyzed and can be a secondary fuel termed standard fuel or a tertiary fuel termed prototype fuel.

1.4 The test method utilizes a knock testing unit/automated analyzer system that incorporates computer control of a standardized single-cylinder, four-stroke cycle, variable compression ratio, carbureted, CFR engine with appropriate auxiliary equipment using either Test Method [D2699](#) Research method or Test Method [D2700](#) Motor method operating conditions.

1.4.1 Knock measurements are based on operation of both fuels at the specific fuel-air ratio that produces maximum knock intensity for that fuel.

1.4.2 Measured differences in knock intensity are scaled to provide a positive or negative delta octane number of the stream sample from the comparison reference fuel when the fuels are compared at the same compression ratio.

1.4.3 Measured differences in compression ratio are scaled to provide a positive or negative delta octane number of the stream sample from the comparison reference fuel when the fuels are compared at the same knock intensity.

1.5 This test method is limited to testing 78 to 102 octane number spark-ignition engine fuels using either research or motor method conditions.

1.6 The octane number difference between the stream sample and the applicable comparison reference fuel is self-limiting by specifications imposed upon the standard and prototype fuels.

1.7 Specifications for selection, preparation, storage, and dispensing of standard and prototype fuels are provided. Detailed procedures for determination of an appropriate assigned octane number for both standard and prototype fuels are also incorporated.

1.8 The values of operating conditions are stated in SI units and are considered standard. The values in parentheses are historical inch-pound units. The standardized CFR engine measurements continue to be expressed in inch-pound units only because of the extensive and expensive tooling that has been created for this equipment.

1.9 *This standard does not purport to address all of the safety concerns, if any, associated with its use. It is the responsibility of the user of this standard to establish appropriate safety and health practices and determine the applicability of regulatory limitations prior to use.* For more specific warning statements, see Section 8 and [Annex A1](#).

2. Referenced Documents

2.1 ASTM Standards:²

[D1193](#) Specification for Reagent Water

[D2699](#) Test Method for Research Octane Number of Spark-Ignition Engine Fuel

[D2700](#) Test Method for Motor Octane Number of Spark-Ignition Engine Fuel

[D4057](#) Practice for Manual Sampling of Petroleum and Petroleum Products

[D4175](#) Terminology Relating to Petroleum, Petroleum Products, and Lubricants

[D4177](#) Practice for Automatic Sampling of Petroleum and Petroleum Products

¹ This test method is under the jurisdiction of ASTM Committee [D02](#) on Petroleum Products and Lubricants and is the direct responsibility of Subcommittee [D02.01](#) on Combustion Characteristics.

Current edition approved June 15, 2013. Published July 2013. Originally approved in 1970. Last previous edition approved in 2010 as D2885 – 10a. DOI: 10.1520/D2885-13.

² For referenced ASTM standards, visit the ASTM website, www.astm.org, or contact ASTM Customer Service at service@astm.org. For *Annual Book of ASTM Standards* volume information, refer to the standard's Document Summary page on the ASTM website.

*A Summary of Changes section appears at the end of this standard

- [D4814 Specification for Automotive Spark-Ignition Engine Fuel](#)
- [D6299 Practice for Applying Statistical Quality Assurance and Control Charting Techniques to Evaluate Analytical Measurement System Performance](#)
- [D5842 Practice for Sampling and Handling of Fuels for Volatility Measurement](#)
- [D6300 Practice for Determination of Precision and Bias Data for Use in Test Methods for Petroleum Products and Lubricants](#)
- [D6624 Practice for Determining a Flow-Proportioned Average Property Value \(FPAPV\) for a Collected Batch of Process Stream Material Using Stream Analyzer Data](#)
- [D7453 Practice for Sampling of Petroleum Products for Analysis by Process Stream Analyzers and for Process Stream Analyzer System Validation](#)
- [E177 Practice for Use of the Terms Precision and Bias in ASTM Test Methods](#)
- [E456 Terminology Relating to Quality and Statistics](#)
- 2.2 *Waukesha CFR Engine Manuals:*
- [CFR F-1 & F-2 Octane Rating Units Operation & Maintenance FORM 847³](#)

3. Terminology

3.1 Definitions:

3.1.1 *accepted reference value, n*—a value that serves as an agreed-upon reference for comparison, and which is derived as: (1) a theoretical or established value, based on scientific principles, (2) an assigned value, based on experimental work of some national or international organization, or (3) a consensus value, based on collaborative experimental work under the auspices of a scientific or engineering group. **E456/E177**

3.1.1.1 *Discussion*—In the context of this test method, accepted reference value is understood to apply to standard fuel or check fuel average research or motor octane numbers determined under reproducibility conditions by a recognized exchange testing organization having a minimum of 16 participants.

3.1.2 *analytical measurement system, n*—a collection of one or more components or subsystems, such as a sampler, test equipment, instrumentation, display devices, data handler, and printout or output transmitters that is used to determine a quantitative value of a specific property for an unknown sample. **D6299**

3.1.2.1 *Discussion*—In the context of this test method, the analytical measurement system is comprised of the knock testing unit, automated analyzer system, and any auxiliary equipment required for the safe operation of the engine.

3.1.3 *cylinder height, n—for the CFR engine*, the relative vertical position of the engine cylinder with respect to the

piston at top dead center (TDC) or the top machine surface of the crankcase. **D2699/D2700**

3.1.4 *determinability, n*—quantitative measure of the variability associated with the same operator in a given laboratory obtaining successive determined values using the same apparatus for a series of operations leading to a single result; it is defined as that difference between two such single determined values as would be exceeded in the long run in only one case in 20 in the normal and correct operation of the test method. **D6300**

3.1.5 *detonation meter, n—for knock testing*, the signal conditioning instrument that accepts the electrical signal from the detonation pickup and provides an output signal for display. **D2699/D2700**

3.1.6 *detonation pickup, n—for knock testing*, magnetostrictive type transducer that threads into the engine cylinder and is exposed to combustion chamber pressure to provide an electrical signal that is proportional to the rate-of-change of cylinder pressure. **D2699/D2700**

3.1.7 *digital counter reading, n—for the CFR engine*, a numerical indication of cylinder height, indexed to a basic setting at a prescribed compression pressure when the engine is motored. **D2699/D2700**

3.1.8 *fuel-air ratio for maximum knock intensity, n—for knock testing*, that proportion of fuel to air which produces the highest knock intensity for each fuel in the knock testing unit, provided this occurs within the specified carburetor fuel level limits. **D2699/D2700**

3.1.8.1 *Discussion*—In the context of this test method, the fuel-air ratio for maximum knock intensity can be determined manually or by the automated analyzer system.

3.1.8.1 *dynamic fuel-air ratio for maximum knock, n—for knock testing*, the changing of the mixture of fuel and air for engine combustion determined by continually varying fuel level in the carburetor delivery components, through the maximum knock intensity so that the observed peak knock intensity value can be selected as maximum knock intensity reading.

3.1.8.2 *equilibrium fuel-air ratio for maximum knock, n—for knock testing*, the changing of the mixture of fuel and air for engine combustion determined by making incremental step changes in fuel-air ratio, observing the equilibrium knock intensity for each step and selecting the fuel-air ratio which produces the highest knock meter reading.

3.1.9 *guide tables, n—for knock testing*, the specific relationship between cylinder height (compression ratio) and octane number at standard knock intensity. **D2699/D2700**

3.1.10 *knock, n—in a spark-ignition engine*, abnormal combustion, often producing audible sound, caused by auto-ignition of the air/fuel mixture. **D4175**

3.1.11 *knock intensity, n—for knock testing*, a measure of the level of knock. **D2699/D2700**

3.1.12 *knockmeter, n—for knock testing*, the 0 to 100 division indicating meter that displays the knock intensity signal from the detonation meter. **D2699/D2700**

³ The sole source of supply of the apparatus known to the committee at this time is Waukesha Engine Division, Dresser Equipment Group, Inc., 1000 W. St. Paul Avenue, Waukesha, WI 53188. Waukesha Engine Division also has CFR engine authorized sales and service organizations in selected geographical areas. If you are aware of alternative suppliers, please provide this information to ASTM International Headquarters. Your comments will receive careful consideration at a meeting of the responsible technical committee,¹ which you may attend.

3.1.12.1 *Discussion*—In the context of this test method, the knock intensity signal may also be displayed using digital or recording instrumentation.

3.1.13 *motor octane number, n—for spark-ignition engine fuel*, the numerical rating of knock resistance obtained by comparison of the fuel’s knock intensity with that of primary reference fuel blends when both are tested in a standardized CFR engine operating under the conditions specified in Test Method **D2700**.

3.1.14 *repeatability conditions, n—conditions where independent test results are obtained with the same method on identical test items in the same laboratory by the same operator using the same equipment within short intervals of time.* **E456**

3.1.14.1 *Discussion*—In the context of this test method, application of repeatability conditions is primarily applied to the determination of variability of delta octane numbers generated by repeating the comparison measurements within a short time, by the same operator, using the same comparator, on the same fuel pair.

3.1.15 *reproducibility conditions, n—conditions where test results are obtained with the same method on identical test items in different laboratories with different operators using different equipment.* **E456**

3.1.16 *research octane number, n—for spark-ignition engine fuel*, the numerical rating of knock resistance obtained by comparison of the fuel’s knock intensity with that of primary reference fuel blends when both are tested in a standardized CFR engine operating under the conditions specified in Test Method **D2699**.

3.1.17 *spread, n—in knock measurement*, the sensitivity of the detonation meter expressed in knockmeter divisions per octane number. **D2699/D2700**

3.1.18 *site assigned value, n—a value that serves as an agreed-upon reference for comparison, determined from multiple test results obtained under site precision conditions.*

3.1.18.1 *Discussion*—In the context of this test method, site assigned value is understood to apply to prototype fuel average research or motor octane number determined under site precision conditions using direct comparison delta octane number cycles comparing the prototype fuel to a standard fuel having an accepted reference value octane number.

3.1.19 *site precision conditions, n—conditions under which test results are obtained by one or more operators in a single location practicing the same test method on a single measurement system using test specimens taken at random from the same sample of material over an extended period of time spanning at least a 15 day interval.* **D6299**

3.1.19.1 *Discussion*—In the context of this test method, application of site precision conditions is primarily applied to the determination of the variability of delta octane average results, obtained by different operators, over different days, for the same fuel pair, using the same comparator. Each delta octane average result is obtained from repetitive comparisons of the same fuel pair under repeatability conditions.

3.1.20 *stream sample, n—the material to be evaluated by an analytical measurement system, typically drawn from a flowing stream of either blended spark-ignition engine fuel or process unit material.*

3.2 *Definitions of Terms Specific to This Standard:*

3.2.1 *comparison reference fuel, n—for direct comparison knock testing*, a spark-ignition engine fuel having an assigned octane number that is the reference for the determination of the delta octane number of stream samples.

3.2.1.1 *standard fuel, n—for direct comparison knock testing*, a spark-ignition engine fuel having an octane number accepted reference value (RON_{ARV} or MON_{ARV}) which is used as a secondary comparison reference fuel for (1) determination of the octane number site assigned value (RON_{SAV} or MON_{SAV}) of prototype fuels, (2) determination of the $\Delta O.N.$ of a stream sample, or (3) pairing with another standard fuel for analytical measurement system qualification checkout.

3.2.1.2 *prototype fuel, n—for direct comparison knock testing*, a spark-ignition engine fuel or process unit material having an octane number site assigned value (RON_{SAV} or MON_{SAV}) referenced to an appropriate standard fuel, which is used as a tertiary comparison reference fuel for determination of the $\Delta O.N.$ of a stream sample.

3.2.2 *delta octane number, n—for direct comparison knock testing*, the algebraic difference in octane number between two fuels under research or motor engine conditions, when determined by the direct comparison technique.

3.2.3 *paired check fuels (A and B), n—for on-line knock testing system qualification checkout*, two standard fuels used for system qualification checkout of a analytical measurement system.

3.2.3.1 *expected difference O.N., n—for on-line knock testing system qualification checkout*, the absolute octane number difference between paired check fuels (A–B) based on the $O.N._{ARV}$ for both fuels.

3.2.4 *paired quality control fuels, n—for on-line system quality control*, a pair of fuels, one of which is a comparison reference fuel, to be used in the repetitive testing for $\Delta O.N.$ as a quality control check of the analytical measurement system.

3.2.5 *span, n—for direct comparison knock testing*, a measure of the overall sensitivity of the analyzer. The ratio of the change in delta octane reported produced by a given change in either compression ratio or knock intensity.

3.3 *Acronyms:*

3.3.1 *AMS*—analytical measurement system

3.3.2 *ARV*—accepted reference value

3.3.3 *RON_{ARV}* —research octane number accepted reference value

3.3.4 *MON_{ARV}* —motor octane number accepted reference value

3.3.5 *SAV*—site assigned value

3.3.6 *RON_{SAV}* —research octane number site assigned value

3.3.7 *MON_{SAV}* —motor octane number site assigned value

3.3.8 *C.R.*—compression ratio

- 3.3.9 *K.I.*—knock intensity
- 3.3.10 *O.N.*—octane number
- 3.3.11 $\Delta O.N.$ —delta octane number
- 3.3.12 *PRF*—primary reference fuel
- 3.3.13 *CRF*—comparison reference fuel
- 3.4 *Symbols:*
- 3.4.1 *Q*—accuracy qualification value
- 3.4.2 *K*—accuracy qualification acceptance limit

4. Summary of Test Method

4.1 The delta research (ΔRON) or delta motor (ΔMON) octane number of a stream sample is determined using a standard CFR engine operating under the appropriate test conditions, using an automated repetitive cycle that compares its knock characteristics with those of a comparison reference fuel (CRF) having an assigned octane number. The difference in knock characteristics may be measured as (1) the difference in knock intensity at constant compression ratio, or (2) the difference in compression ratio at constant knock intensity. The system draws the stream sample from a flowing stream and conditions it for delivery to the CFR engine carburetor. Comparison reference fuel is stored in a suitable container and is also appropriately conditioned for delivery to the CFR engine carburetor. System controls sequence the switching of the two fuels as well as monitoring all critical testing variables. The fuel-air ratio of each fuel is adjusted to produce the maximum knock intensity for that fuel.

5. Significance and Use

5.1 The delta octane number ($\Delta O.N.$) measure can quantify the difference of in-line blended spark-ignition engine fuel or process stream material octane number to a desired octane number to aid in optimizing control of blender facilities or refinery process units.

5.2 The $\Delta O.N.$ measure, summed with a statistically sound comparison reference fuels *O.N.* provides either research or motor octane number value of the current in-line blended spark-ignition engine fuel or process stream material.

5.3 Through the use of cumulative flow-weighted averaging of the repetitive $\Delta O.N.$ results, a statistically significant octane number can be assigned to a tender or batch of in-line blended spark-ignition engine fuel.

6. Interferences

6.1 Certain gases and fumes, which can be present in the area where the knock testing unit is located, may have a measurable effect on the $\Delta O.N.$ result.

6.1.1 Halogenated refrigerant used in air conditioning and refrigeration equipment can promote knock. Halogenated solvents can have the same effect. If vapors from these materials enter the combustion chamber of the CFR engine, the octane number of spark-ignition engine fuel can be depreciated.

6.2 Electrical power subject to transient voltage or frequency surges or distortion can alter CFR engine operating

conditions or knock measuring instrumentation performance and thus affect the $\Delta O.N.$ obtained for spark-ignition engine fuels.

6.2.1 Electrical noise can affect the ability of the knock testing unit/automated analytical measurement system to accurately determine the $\Delta O.N.$ of the sample stream fuel.

6.3 *Precaution*—Avoid exposure of sample fuels to sunlight or fluorescent lamp UV emissions to minimize induced chemical reactions that can affect octane number ratings.⁴

6.3.1 Exposure of these fuels to UV wavelengths shorter than 550 nanometers for a short period of time may significantly affect octane number ratings.⁴

7. Apparatus

7.1 This test method utilizes a multi-component analytical measurement system (AMS). It incorporates a knock testing engine with instrumentation to measure and produce an output signal representative of the difference in knock rating or $\Delta O.N.$ An associated automated control system includes a fuel delivery system to introduce a stream sample or CRF to the engine critical carburetor components. The automated system shall also include equipment and controls for switching between the CRF and the stream sample, controls for operating the test engine and monitoring the critical operating conditions, and instrumentation to convert the compression ratio (C.R.) or knock intensity (K.I.) to a $\Delta O.N.$

7.1.1 An appropriate CFR engine knock testing unit specified for the determination of research octane number or motor octane number and meeting the recommendations of the manufacturer of the AMS. Specific knock testing unit equipment can include the following:

7.1.1.1 For research octane number measurement, a Model CFR F-1, single cylinder engine knock testing unit assembly comprised of the appropriate critical or equivalent equipment components selected by the system manufacturer, and for which specifications are provided in Test Method [D2699](#), Annex A2.³

7.1.1.2 For motor octane number measurement, a Model CFR F-2, single cylinder engine knock testing unit assembly comprised of the appropriate critical or equivalent equipment components selected by the system manufacturer, and for which specifications are provided in Test Method [D2700](#), Annex A2.³

7.1.1.3 Instrumentation for the measurement of knock, temperatures or other knock testing unit variables as selected by the system manufacturer, and for which specifications are provided in Annex A2, of either Test Method [D2699](#) or Test Method [D2700](#), whichever is appropriate.

7.1.1.4 The AMS system installation requires a number of components and devices to integrate the critical or equivalent equipment items into a complete working unit. Specific items to satisfy important criteria for proper operation of the respective CFR engine unit are to comply with the appropriate

⁴ Supporting data have been filed at ASTM International Headquarters and may be obtained by requesting Research Report RR:D02-1502.

non-critical equipment specifications in Annex A2, of either Test Method [D2699](#) or Test Method [D2700](#), whichever is appropriate.

7.1.1.5 Equipment for adjustment of engine compression ratio and a mechanism for relative measurement of this variable when the Δ O.N. value is based on differences in engine compression ratio.

7.1.2 Automated control equipment for adjustment and monitoring of the critical operating variables of the knock testing unit is required and selected in accordance with the recommendations and instructions of the system manufacturer. Specific variables and conditions to be handled by the automated control equipment can include the following:

7.1.2.1 A mechanism to vary fuel-air ratio and determine the condition that produces a maximum K.I. signal. Determination of the fuel-air ratio for maximum knock intensity can be performed using either the equilibrium or a dynamic search technique.

7.1.2.2 An adjustable octane number scaling function to convert the measured signal variable to an output signal Δ O.N. value, recognizing any non-linear relationship that can exist.

7.1.2.3 Timing controls for fuel switching and measurement functions to meet the specified operating principles of this test method.

7.1.2.4 Suitable sensors for monitoring operating conditions and system safety related functions that are incorporated in the system design.

7.1.3 A sample system to provide a continuously representative stream and deal with the unconsumed stream sample.

7.1.3.1 Equipment to treat the incoming stream sample fuel to remove particulate matter and entrained water to meet the requirements specified by the system manufacturer.

7.1.4 Storage vessels and associated equipment for storing and supplying one or more CRF materials.

8. Reagents and Reference Materials

8.1 *Cylinder Jacket Coolant*—Use water in the cylinder jacket for engine locations where the resultant boiling temperature will be $100 \pm 1.5^\circ\text{C}$ ($212 \pm 3^\circ\text{F}$). Use water with commercial glycol based antifreeze added in sufficient quantity to meet the boiling temperature requirements where altitude dictates. A commercial multifunction water treatment material can be used in the coolant to minimize corrosion and mineral scale that can alter heat transfer and rating results.

8.1.1 Water is understood to mean reagent water conforming to type IV, Specification [D1193](#). (**Warning**—Ethylene glycol based antifreeze is poisonous and may be harmful or fatal if inhaled or swallowed. See [Annex A1](#).)

8.2 *Engine Crankcase Lubricating Oil*—SAE 30 viscosity grade oil meeting the current API service classification for spark-ignition engines containing a detergent additive and having a kinematic viscosity of 9.3 to 12.5 mm² per s (cst) at 100°C (212°F) and a viscosity index of not less than 85. Do not use oils containing viscosity index improvers or multigrade oils. (**Warning**—Lubricating oil is combustible and its vapor is harmful. See [Annex A1](#).)

8.3 *Standard Fuel*—(**Warning**—Standard fuel is flammable and its vapors are harmful. Vapors may cause flash fire. See

[Annex A1](#).) A secondary comparison reference fuel that conforms to the following:

8.3.1 *Octane Number*—Selected to have a RON_{ARV} or MON_{ARV} with respect to the O.N. of the prototype fuel or the stream samples to be analyzed.

8.3.1.1 The difference between standard fuel and related prototype fuel shall not exceed ± 0.5 O.N.

8.3.1.2 The difference between standard fuel and the stream samples to be analyzed shall not exceed ± 1.0 O.N.

(1) *Discussion*—The difference between the standard fuel and the stream sample refers to when the standard fuel is used in direct comparison to the stream sample.

8.3.1.3 Determine the appropriate O.N._{ARV} of standard fuel under reproducibility conditions using a minimum of 16 different exchange participants (see [Annex A3](#)).

8.3.2 *Volatility*—Or use with blended stream samples, the standard fuel can be slightly less volatile than the stream samples to be analyzed in the interest of minimizing weathering.

8.3.2.1 A vapor pressure, as defined in Test Method [D4814](#), of less than 68.9 kPa (10 psi) is preferred but, in any case, it shall not exceed 82.7 kPa (12 psi).

8.3.3 *Hydrocarbon Composition*—Similar to that of a related prototype fuel or the stream samples to be analyzed. Users are cautioned to investigate the O.N. effect of any significant differences in composition matrix between these related fuels.

8.3.4 *Antiknock Compound*—The same organometallic lead or manganese additive compound, in a similar concentration, shall be present in the standard fuel if it is present in the prototype fuel or stream sample to be analyzed.

8.3.5 *Octane Enhancers*—Compounds such as oxygenates shall be present in the standard fuel, in similar concentration, to that present in the prototype fuel or stream sample to be analyzed.

8.3.6 *Antioxidant*—Add at the treat-rate recommended by the additive supplier to ensure maximum storage stability.

8.3.6.1 Add antioxidant prior to distribution of standard fuel for the determination of the O.N._{ARV}.

8.3.7 *Metal Deactivator*—Add in accordance with supplier recommendations if it is deemed necessary.

8.3.8 *Storage and Handling*—Controlled conditions to minimize the possibility of octane number change or contamination. Systems and procedures shall conform to the requirements set forth in [Annex A2](#) of this test method.

8.4 *Prototype Fuel*—(**Warning**—Prototype fuel is flammable and its vapors are harmful. Vapors may cause flash fire. See [Annex A1](#).) A tertiary comparison reference fuel that conforms to the following:

8.4.1 *Octane Number*—The difference between prototype fuel and the stream samples to be analyzed shall not exceed ± 1.0 O.N.

8.4.1.1 Determine the appropriate O.N._{SAV} of prototype fuel based on the average value of a minimum of 10 direct match knock characteristic comparisons, obtained either manually or automatically, under site precision conditions (see [Annex A4](#)).

8.4.2 *Volatility*—For use with blended stream samples, the prototype fuel can be slightly less volatile than the stream samples to be analyzed in the interest of minimizing weathering.

8.4.2.1 A vapor pressure, as defined in Test Method **D4814**, of less than 68.9 kPa (10 psi) is preferred but, in any case, it shall not exceed 82.7 kPa (12 psi).

8.4.3 *Hydrocarbon Composition*—Similar to that of the stream samples to be analyzed. Users are cautioned to investigate the O.N. effect of any significant differences in composition matrix between these related fuels.

8.4.4 *Antiknock Compound*—The same organometallic lead or manganese additive compound, in a similar concentration, shall be present in the prototype fuel if it is present in the stream sample to be analyzed.

8.4.5 *Octane Enhancers*—Compounds such as oxygenates shall be present in the prototype fuel, in similar concentration, to that present in the stream sample to be analyzed.

8.4.6 *Antioxidant*—Add at the treat-rate recommended by the additive supplier to ensure maximum storage stability.

8.4.7 *Metal Deactivator*—Add in accordance with supplier recommendations if it is deemed necessary.

8.4.8 *Storage and Handling*—Control conditions to minimize the possibility of octane number change or contamination. Systems and procedures shall conform to the recommendations set forth in **Annex A2**.

8.5 *Paired Check Fuels*—The paired check fuels will have an expected difference O.N. ranging from 0.2 to 1.0 and be coded so the difference in the accepted reference values (Fuel A–Fuel B) is a positive value.

8.5.1 The fuel characteristics, including those for antiknock compound, octane enhancers, and antioxidant protection are to be similar for the two check fuels of a pair.

8.6 *Paired Quality Control Fuels*—The two quality control fuels, one of which is a comparison reference fuel, shall have Δ O.N. ranging from 0.2 to 1.0.

8.7 *Primary Reference Fuels*—Reference fuel grade isooctane, heptane, the 80 O.N. blend of the two meeting the specifications given in Test Method **D2699** or Test Method **D2700**, or both. (**Warning**—Primary reference fuels are flammable and the vapors are harmful. Vapors may cause flash fire. See **Annex A1**.)

9. Sampling

9.1 Collect stream samples for on-line analysis in accordance with Practice **D4177** or **D7453**.

9.1.1 Collect, treat, and deliver stream samples to the CFR engine carburetor in a way that minimizes exposure to light of any form.

9.2 Collect stream sample material for preparation, storage and laboratory testing as comparison reference fuels in accordance with Practices **D4057**, **D4177**, and **D5842**.

9.2.1 Collect and store sample fuels in an opaque container, such as a dark brown glass bottle, metal can, or a minimally reactive plastic container to minimize exposure to UV emissions from sources such as sunlight or fluorescent lamps.

10. Basic Engine and Instrument Settings and Operating Conditions

10.1 *Standard Operating Conditions:*

10.1.1 *Installation of CFR Engine Equipment and Instrumentation*—Place the CFR engine on a suitable foundation and hook up all utilities in accordance with the specifications of the engine manufacturer. Assemble the supplemental automated analyzer system and fuel delivery system components in accordance with the instructions of the system manufacturer. All installation aspects are to comply with local and national codes and installation requirements.

10.1.2 Proper operation of the CFR engine requires assembly of a number of engine components and adjustment of a series of engine variables to prescribed specifications. These settings and adjustments are specified in the CFR F-1 & F-2 Octane Rating Unit Operation & Maintenance Manual and in the Basic Engine and Instrument Settings And Standard Operating Conditions sections of Test Method **D2699** or Test Method **D2700**, or both, and are of the following types:

10.1.2.1 Conditions based on component specifications (**Annex A2** and **A3** of Test Method **D2699** or Test Method **D2700**, or both).

10.1.2.2 CFR engine assembly settings and operating conditions.

10.1.2.3 Proper operation of the automated analyzer system equipment and instrumentation.

10.2 *CFR Engine Assembly Settings and Operating Conditions:*

10.2.1 *Compensation of Compression Ratio for Standard Knock Intensity*—Knock testing engines operating at sites where the barometric pressure is lower or higher than 29.92 in. Hg, standard pressure, will knock softer or harder respectively than the engines operating at standard pressure. To compensate for this effect, the engine compression ratio is adjusted proportional to the difference between the site median and standard barometric pressure. The range of barometric pressure experienced at any testing location is generally less than 1.5 in. Hg and the compression ratio compensation to cause essentially standard knock intensity at the location can be achieved using a fixed offset based on median barometric pressure for the site. This compensation can be made once by setting the offset between the two dials of the digital counter and using the compensated digital counter reading for the Δ O.N. measurement.

10.2.1.1 Determine the range of barometric pressure that typically occurs at the site for the year and calculate the median barometric pressure. If there are significant seasonal differences, it may be appropriate to calculate the median barometric pressure for each season.

10.2.1.2 Using the median barometric pressure and Table A4.4 or A4.5 of Test Method **D2699** for research octane number units and Table A4.9 or A4.10 of Test Method **D2700** for motor octane number units determine the compensation for guide table cylinder height (digital counter reading).

10.2.1.3 Set the digital counter so that the lower dial reading is compensated for the site median difference in barometric pressure from the 29.92 in. Hg standard pressure.

10.2.2 *Selecting and Setting Compression Ratio for On-line Operation*—On-line Δ O.N. measurement for a given pair of fuels is initiated by setting the engine compression ratio to the guide table digital counter reading that corresponds to the appropriate CRF assigned octane number from the tables in Annex A4 in Test Method **D2699** or Test Method **D2700**, whichever is appropriate, for the AMS.

10.2.2.1 For systems that operate at a constant C.R., the barometric pressure at the site may change slightly with time and this will result in minor shifts in engine K.I. level. If the K.I. on the comparison reference fuel trends below 35 or above 65 the AMS may be taken off-line, for a short period of time, to reset the K.I. to 50 by adjusting the detonation meter -METER READING- dial before continuing on-line analysis.

10.2.2.2 For systems that operate at a constant K.I. by adjustment of compression ratio the barometric pressure at the site may change slightly with time and this will result in minor shifts in the digital counter reading. If the digital counter reading for the reference fuel trends more than 20 units, the AMS may be taken off-line, for a short period of time, to reset the K.I. to 50 at the CRF O.N. digital counter reading by adjusting the detonation meter -METER READING- dial before continuing on-line.

10.2.2.3 Typical minor shifts in either knock intensity or digital counter reading affect each of the fuels under test in the same manner and these shifts do not significantly affect the Δ O.N. measurement.

10.2.3 *Span Determination and Adjustment*—The span setting for the analyzer is critical for the accurate determination of Δ O.N. The engine spread for constant C.R. systems or adherence to guide table readings for constant K.I. systems at the octane range of the standard or prototype fuel must be accurately determined and reflected in the analyzer span.

10.2.3.1 For AMS operating at a constant compression ratio, the span setting (K.I./octane) is to be determined by the running of two PRF fuels with a difference of 1.0 ± 0.2 O.N. on the analyzer as per the manufacturer's instructions. The difference between the two fuels' K.I. readings divided by the difference in the two fuels' O.N. will give the spread for engine at that octane. The spread for the engine at the octane range of the PRFs will then need to be entered into the analyzer software as the span per the manufacturer's instructions.

10.2.3.2 For AMS operating at a constant knock intensity the span setting (C.R./octane) is to be determined by the running of two PRF fuels with a difference of 1.0 ± 0.2 O.N. on the analyzer as per the manufacturer's instructions. The difference in the C.R. between the two fuels divided by the difference O.N. will give the span for the engine at that octane. The span for the engine at the octane range of the PRFs will then need to be entered into the analyzer software as per the manufacturer's instructions.

10.2.4 *Fuel-Air Ratio Characteristic*—With the engine operating at a cylinder height that causes knock, variation of the fuel-air mixture has a characteristic effect, typical for all fuels. This test method specifies that each stream sample and CRF shall be operated at the fuel-air ratio that produces the maximum K.I. To maintain good fuel vaporization, a restrictive orifice or horizontal jet is utilized so that the maximum knock

condition occurs for fuel levels between 0.7 and 1.7 in. referenced to the centerline of the carburetor venturi. The mechanics for varying the fuel mixture can be accomplished using various approaches.

10.2.4.1 *Fixed Horizontal Jet—Variable Fuel Level System*—Fuel level adjustments are made by varying the float reservoir in incremental steps. Selection of a horizontal jet having the appropriate orifice size establishes the fuel level at which a typical sample fuel achieves maximum knock.

10.2.4.2 *Fixed Fuel Level—Variable Orifice System*—A fuel reservoir, in which the fuel can be maintained at a prescribed constant level, supplies an adjustable orifice (special long-tapered needle valve) used in place of the horizontal jet. Fuel mixture is changed by varying the needle valve position. Typically, the constant fuel level selected is near the 1.0 level, which satisfies the fuel level specification.

10.2.4.3 *Dynamic or Falling Level System*—A fuel reservoir, filled to a higher level than that required for maximum K.I., delivers fuel through either a fixed bore or adjustable horizontal jet. With the engine firing, the fuel level falls as fuel is consumed. Fuel level changes at a specifically selected rate that is established by the cross-sectional area of the fuel reservoir and associated sight glass assembly. Maximum K.I. is recorded as the fuel level passes through the critical level.

10.2.5 *Intake Air and Mixture Temperature Setting Practices:*

10.2.5.1 *Motor Method:*

(1) *Intake Air Temperature*— $38 \pm 2.8^\circ\text{C}$ ($100 \pm 5^\circ\text{F}$).

(2) *Intake Mixture Temperature*— $149 \pm 1^\circ\text{C}$ ($300 \pm 2^\circ\text{F}$) maintained within 1°C ($\pm 2^\circ\text{F}$) when C.R. or K.I. results used for a delta octane measurement are recorded.

10.2.5.2 *Research Method:*

(1) *Intake Air Temperature*— $52 \pm 1^\circ\text{C}$ ($125 \pm 2^\circ\text{F}$) is specified for operation at standard barometric pressure of 101.0 kPa (29.92 in. Hg). IATs for other than standard barometric pressure conditions need to be adjusted to compensate for the site median barometric pressure.

(2) Determine the site median barometric pressure (see details previously given under Site Compensation of Compression Ratio for Standard Knock Intensity).

(3) Use the site median barometric pressure and Table A4.4 or A4.5 of Test Method **D2699** to determine the applicable intake air temperature.

(4) Adjust analyzer measurement system settings to deliver the compensated intake air temperature and this temperature shall then be maintained within $\pm 1^\circ\text{C}$ ($\pm 2^\circ\text{F}$) when C.R. or K.I. results used for a delta octane measurement are recorded.

10.3 *Proper Operation of the Automated Analyzer System Equipment and Instrumentation:*

10.3.1 *Sample Stream Sampling Systems:*

10.3.1.1 *Cyclic and Continuous Fuel Sampling Techniques*—AMS can determine the knock characteristic measurement using either a grab sample or continuously flowing sample.

10.3.1.2 For the continuously flowing sample approach, fuel is continuously delivered to the CFR engine carburetor while

knock measurement is in progress, and any unconsumed fuel is removed from the AMS.

10.3.1.3 For the intermittent or grab sample approach, a carburetor device isolates a portion of either the stream sample or CRF, then performs the knock measurement sequence on that sample.

10.3.1.4 The system needs to operate on each fuel for a minimum of 4 min. The time periods spent on each fuel can be set based on engine operation and site requirements.

10.3.1.5 The system must be rating the sample stream for a minimum of 50 % of the cycle time.

10.3.2 *Sample Temperature*—Deliver the CRF and sample fuel to the knock-testing unit critical carburetor components at the same nominal temperature. This temperature shall be greater than 0°C (32°F) but not exceed 10°C (50°F).

10.3.3 *System Alarm Functions*—AMS systems for unattended operation utilize sensors, control logic, and other devices designed to protect the system and facilities from abnormal conditions. Some typical sensors are: low crankcase oil pressure, loss of jacket coolant, loss of sample stream pressure or flow, or both, excessive C.R. as evidenced by cylinder height limits, indication of system measurement instability as evidenced by out-of-limit repeatability measurements for comparison reference fuel, the presence of hydrocarbon vapors at the unit, the presence of carbon monoxide in the room atmosphere, and so forth. Some alarm functions are active and result in system shutdown. Other alarms are passive and simply indicate an operating characteristic that is out of performance limits.

11. System Qualification Checkout

11.1 Check the performance of the AMS at intervals in accordance with the user quality system or after any maintenance that could affect measurement system performance. Operate the system using paired check fuels to determine whether it produces the correct $\Delta O.N.$ value and does so with appropriate system stability.

11.1.1 The $\Delta O.N.$ value is dependent upon (1) knock testing unit sensitivity, (2) detonation meter sensitivity, and (3) automated analyzer span setting for the octane range to be used.

11.1.2 The knock testing unit must be able to repeatedly measure the $\Delta O.N.$ for two fuels of different octane number. The latitude of engine condition is quite broad and when the knock testing unit is no longer satisfactory for automated analyzer operation it will be evidenced as instability of knock intensity. This condition often can be rectified through carbon blasting and ultimately by cylinder overhaul.

11.1.3 Set the span according to the manufacturer's instructions for the desired octane range so that the knock intensity or compression ratios can be used to accurately calculate the $\Delta O.N.$

11.2 Perform the qualification checkout with the AMS operating under standard conditions as specified in this method. Equal time periods of operation for each of the paired check fuels shall be used. The time period for operation on each fuel shall be 4 min or longer.

11.2.1 Sequence the AMS between the paired check fuels until a minimum of six cycles has completed. A complete cycle

comprises one period of operation on one fuel (A), followed by one period on the second fuel (B). Sequence the check fuels to the analyzer measurement system so that the $\Delta O.N.$ values are determined by subtracting the fuel B result from the fuel A result.

11.3 *Determination of Average $\Delta O.N.$:*

11.3.1 Discard the $\Delta O.N.$ result for the first complete cycle determination.

11.3.2 Tabulate the remaining $\Delta O.N.$ values (Fuel B from Fuel A), including the proper algebraic sign.

11.3.3 Calculate the average $\Delta O.N.$, with respect to algebraic sign.

11.4 *System Accuracy Qualification:*

11.4.1 Assess the accuracy of the system by comparing the measured average $\Delta O.N.$ for the paired check fuels to the expected difference $O.N.$

11.4.1.1 Calculate Q , the accuracy qualification value, using the following formula:

$$Q = \text{measured average } \Delta O.N. - \text{expected difference } O.N.$$

11.4.1.2 Use **Table 1** to determine if the calculated Q value is within the accuracy qualification acceptance limit, K , for the applicable test method operating conditions (RON or MON).

11.4.1.3 The calculated Q value would, in the long run, in the normal and correct operation of this test method, fall outside the accuracy qualification acceptance limits (K) in only 1 case in 20.

11.4.1.4 If Q is within the limits of K for the respective test method, AMS is considered to be acceptably accurate.

11.4.1.5 If Q is outside the limits of K for the respective test method, the system is considered to be inaccurate and evaluation is required to identify and correct the root cause(s) of the inaccuracy before the system is used for $\Delta O.N.$ ratings of stream samples.

11.5 *System Stability Assessment:*

11.5.1 Assess the stability of the system by comparing the $\Delta O.N.$ range value for the paired check fuels data to the Range Limit (L) in **Table 2** for the respective test method.

NOTE 1—Range limit (L) values listed in **Table 2** are for use with data sets of five independent $\Delta O.N.$ determinations and infer a Type 1 error of approximately 1 %.

11.5.1.1 Calculate the range value, using the following formula:

$$\text{Range value} = \text{maximum measured } \Delta O.N. - \text{minimum measured } \Delta O.N.$$

11.5.1.2 If the $\Delta O.N.$ range value is less than the range limit (L) for the respective test method, AMS is considered to be acceptably stable.

11.5.1.3 If the $\Delta O.N.$ range value is greater than the range limit (L) for the respective method operating conditions, the

TABLE 1 Accuracy Qualification Acceptance Limit Values, K

Test Method	Accuracy Qualification Acceptance Limit
Research	± 0.4
Motor	± 0.4

TABLE 2 Δ O.N. Range Limit Values, L

Test Method	Δ O.N. Range Limit, L
Research	0.3
Motor	0.4

system is considered to be unstable. Evaluation is required to identify and correct the root cause(s) of the instability before the system is used for Δ O.N. ratings of stream samples.

12. Procedure

12.1 Detailed operating procedures shall conform to the recommendations of the AMS manufacturer.

13. Calculation of Delta Octane Number and Octane Number

13.1 Δ O.N. calculation involves taking the signed difference in knock intensity or compression ratio signals between the reference fuel (standard or prototype) and the stream sample fuel and then dividing it by the appropriate span.

13.1.1 *Differential Knock Intensity at a Constant Compression Ratio:*

$$\Delta\text{O.N.} = (\text{K.I. reference} - \text{K.I. sample}) / \text{Span (K.I./octane)}$$

Example:

$$\text{K.I. Reference Fuel} = 50$$

$$\text{K.I. sample fuel} = 57$$

$$\text{Span (K.I./Octane)} = 20$$

$$\Delta\text{O.N.} = (50 - 57) / 20$$

$$\Delta\text{O.N.} = -0.35$$

13.1.2 *Differential Compression Ratio at a Constant Knock Intensity:*

$$\Delta\text{O.N.} = (\text{C.R. sample} - \text{C.R. reference}) / \text{Span (C.R./octane)}$$

Example:

$$\text{Reference Fuel C.R.} = 756$$

$$\text{Sample Fuel C.R.} = 764$$

$$\text{Span (C.R./Octane)} = 14$$

$$\Delta\text{O.N.} = (764 - 756) / 14$$

$$\Delta\text{O.N.} = +0.57$$

13.2 Octane number using the measured delta octane number and the octane number of the comparison reference fuel:

13.2.1 O.N. stream sample = Δ O.N. + O.N. comparison reference fuel.

14. Analytical Measurement System Quality Control Checks

14.1 Confirm the operation of the analytical measurement system and CRF quality by measuring a Δ O.N. between the CRF and a paired quality control fuel at least once a week or when the CRF is used.

14.1.1 Quality control checks are intended to monitor and confirm the stability of the entire Δ O.N. measurement system over time; it is intended as a supplement to the system qualification checkout and can not be used to replace the system qualification checkout.

14.2 Perform the quality control checks with the AMS operating under standard conditions as specified in this method. Use equal time periods of operation for each of the fuels. The time period for operation on each fuel will be 4 min or longer.

14.3 Sequence the AMS between the CRF and paired quality control fuel until a minimum of two cycles has been completed. A complete cycle comprises one period of operation on one fuel (CRF), followed by one period on the second fuel (paired quality control fuel). Sequence the paired quality control fuels to the analyzer measurement system so that the Δ O.N. values are determined by subtracting the paired quality control fuel result from the CRF result.

14.4 *Determination of Average Δ O.N. and Range:*

14.4.1 Tabulate the Δ O.N. values including the proper algebraic sign.

14.4.2 Calculate the average Δ O.N. with respect to algebraic sign.

14.4.3 Calculate the range of data using the following formula:

$$\text{Range of Data} = \text{maximum } \Delta\text{O.N.} - \text{minimum } \Delta\text{O.N.}$$

14.5 Use appropriate control charts or other statistically equivalent technique to assess the average Δ O.N. and range values relative to the established expected values for that pair of quality control fuels. If an out-of-statistical situation is detected, examine the analytical measurement system operation and the CRF quality for root cause(s). The appropriate control charts are I/MR-2 for the average Δ O.N., and range chart for range.

14.6 Specifics for control chart set up and interpretation can be found in Practice [D6299](#).

15. Precision and Bias⁵

15.1 The precision data reported below are based on inter-laboratory data collected by the Motor Fuel Delta Octane Number National Exchange Group from 2002 to 2006 (see Research Report RR:D02-1711).

15.2 Repeatability of individual Δ O.N. results, $r_{\Delta\text{O.N.}}$

15.2.1 Research: $r_{\Delta\text{O.N.},\text{RON}} = 0.2$

15.2.2 Motor: $r_{\Delta\text{O.N.},\text{MON}} = 0.2$

NOTE 2—These repeatability estimates were derived from Δ O.N. data that were generated by repetitive back-to-back testing by on-line analyzer systems of a single sample pair. These conditions are essentially those that have been defined as “determinability” conditions in Practice [D6300](#).

15.3 Reproducibility of average Δ O.N. results, $R_{\text{AVG}\Delta\text{O.N.}}$

15.3.1 The following values were calculated from the averages of six individual Δ O.N. results that are reported for each sample tested by the MFDON National Exchange Group:

15.3.1.1 Research: $R_{\text{AVG}\Delta\text{O.N.},\text{RON}} = 0.5$

15.3.1.2 Motor: $R_{\text{AVG}\Delta\text{O.N.},\text{MON}} = 0.6$

NOTE 3— $R_{\text{AVG}\Delta\text{O.N.}}$ provides a metric for comparing the average Δ O.N. results reported by two different laboratories. If the same gasoline sample were to be analyzed six successive times by two randomly selected D2885

⁵ Supporting data have been filed at ASTM International Headquarters and may be obtained by requesting Research Report RR:D02-1711.

systems, each using the same prototype fuel with the same assigned ON, the probability that the difference in the averages of the six successive results from the two D2885 systems will differ by more than $R_{AVG\Delta O.N.}$ is nominally 5%.

15.4 Reproducibility of FPAPV, $R_{FPAPV_{\Delta O.N.}}$

15.4.1 In the intended on-line application of this test method, multiple $\Delta O.N.$'s are averaged to arrive at a Flow-Proportioned Average Property Value (FPAPV) for the $\Delta O.N.$ of a tender or batch of product. The reproducibility of the FPAPV $_{\Delta O.N.}$ ($R_{FPAPV_{\Delta O.N.}}$), is derived by removing the repeatability component from the reproducibility variance.

15.4.1.1 Research: $R_{FPAPV_{\Delta RON}} = 0.5$

15.4.1.2 Motor: $R_{FPAPV_{\Delta MON}} = 0.5$

NOTE 4— $R_{FPAPV_{\Delta O.N.}}$ provides a metric for assessing the portion of uncertainty associated with the FPAPV octane numbers (FPAPV Octane

Number = Reference Fuel O.N. + FPAPV $_{\Delta O.N.}$) assigned to a batch or tender of product that are due to the uncertainty associated with the FPAPV $_{\Delta O.N.}$ value. If the same batch (entire batch, not aliquot) of gasoline were to be analyzed by two randomly selected D2885 systems, using the same prototype fuel with the same assigned O.N., the probability that the difference in FPAPV from the two D2885 systems will differ by more than $R_{FPAPV_{\Delta O.N.}}$ is nominally 5%.

15.4.2 Users are advised to consult [Appendix X3](#) for a detailed description on how to estimate the variability associated with the FPAPV for octane number of a tender or batch of material obtained using this test method and Practice [D6624](#).

16. Keywords

16.1 analytical measurement system; comparison reference fuel; delta octane number; stream sample fuel

ANNEXES

(Mandatory Information)

A1. HAZARDS INFORMATION

A1.1 Introduction:

A1.1.1 In the performance of this test method there are hazards to personnel. These are indicated in the text. The classification of the hazard, **Warning**, is noted with the appropriate key words of definition. For more detailed information regarding the hazards, refer to the appropriate Material Safety Data Sheet (MSDS) for each of the applicable substances to establish risks, proper handling, and safety precautions.

A1.2 **Warning**—Combustible. Vapor Harmful.

A1.2.1 Applicable Substances:

A1.2.1.1 Engine crankcase lubricating oil.

A1.3 **Warning**—Flammable. Vapors harmful if inhaled. Vapors may cause flash fire.

A1.3.1 Applicable Substances:

A1.3.1.1 Check fuel.

A1.3.1.2 Oxygenate.

A1.3.1.3 Prototype fuel.

A1.3.1.4 Stream Sample fuel.

A1.3.1.5 Standard fuel.

A1.4 **Warning**—Poison. May be fatal if inhaled or swallowed.

A1.4.1 Applicable Substances:

A1.4.1.1 Antifreeze mixture.

A1.4.1.2 Glycol Based Antifreeze.

A1.4.1.3 Halogenated refrigerants.

A1.4.1.4 Halogenated solvents.

A1.4.1.5 Dilute organometallic lead or manganese.

A2. STANDARD AND PROTOTYPE FUEL STORAGE AND HANDLING

A2.1 Select a standard fuel to meet all the requirements in [8.3](#). Handle it with extreme care to avoid the contamination or loss of components from the time of initial bulk collection until its final use.

A2.1.1 Condition the standard fuel to meet the requirements of the AMS for entrained water and particulate matter.

A2.1.2 Bulk Storage Vessel:

A2.1.2.1 Ensure that the volume of the vessel is sufficient to be split into working containers to allow enough for shipping to establishing octane number ARV and for use with the

engines for a realistic period of time. The vessel shall store the fuel with no vapor loss or exposure of the fuel to light.

A2.1.2.2 Clean, dry, and free the vessel of all hydrocarbon soluble contaminants.

A2.1.2.3 Ensure that mixing facilities are part of the vessel or that the vessel tumbles to ensure a homogeneous sample. Mixing time will depend on vessel volume and design.

A2.1.2.4 Ensure that the vessel has provisions for sampling and dispensing into working containers.

A2.1.2.5 Fill the bulk storage vessel from the bottom at a flow rate that does not cause the fuel to “bubble” and flash.

A2.1.2.6 Fill the vessel to 90 % of maximum volume to avoid excess vapor volume.

A2.1.2.7 Split the available volume into working containers at one time if there is to be an increase in the vapor space of the vessel.

A2.1.3 Working Containers:

A2.1.3.1 Ensure that the volume of the working container is sufficient for use to certify a prototype fuel on the analyzer system and takes into account flush volume fuel consumed during the warm-up and setup of the analyzer system, and running of multiple sample cycles. The container shall store the fuel with no vapor loss or exposure of the fuel to light.

A2.1.3.2 Clean, dry, and free the container of all hydrocarbon soluble contaminants.

NOTE A2.1—If the cans have soldered seams, small amounts of flux may contaminate the sample and will reduce its storage stability. Rinse all cans with a quantity of standard fuel prior to filling if there is any doubt about the manner of can fabrication.

A2.1.3.3 *Fuel Dispensing*—Do not allow the method used to transfer the fuel from the bulk receiver to the working container to affect the quality of the fuel in any way.

(1) Chill standard fuel and working containers to below 10°C (50°F) before they are filled.

(2) Flush the fuel dispensing system with sufficient volume to ensure the standard fuel will not be contaminated from any residual fuel in the system.

(3) Fill the working container from the bottom at a flow rate that does not cause the fuel to “bubble” and flash. A fill tube that reaches to the bottom of the can is the most desirable hardware configuration.

(4) Fill the container to 90 % of maximum volume to avoid excess vapor volume.

(5) Fill the working containers without interruption. Cap each one as soon as it has been filled, and number them in sequence.

(6) Do not can the last 8 to 12 L (2 to 3 gal) of standard fuel.

A2.1.3.4 Check working containers for leaks. Do not use contents of leaking cans as standard fuel.

A2.1.3.5 Label the cans for inventory management in accordance with site standards.

A2.1.3.6 Randomly select working containers that are to be used for establishing octane number ARV from the full population.

A2.1.3.7 Ship containers that will be used for establishing octane number ARV in a manner that meets all applicable regulations and safety codes.

A2.1.4 *Storage of Standard Fuel*—To maintain the knock characteristics of the standard fuel, store bulk receivers and working containers away from direct sunlight. Before opening, cool working containers to below 10°C (50°F).

A2.2 *Prototype Fuel*—Select a prototype to meet all the requirements in 8.4. Handle it with extreme care to avoid the contamination or loss of components from the time of initial collection until its final use.

A2.2.1 Do not allow the prototype system to affect the quality of the prototype fuel. Avoid loss of light ends. Avoid water solubility of octane enhancers in water displacement systems. Avoid high nitrogen blanket pressures that cause off-gassing when proto is exposed to ambient pressure.

A2.2.2 *Prototype Tank Volume*—When selecting prototype tank volume, take into account the number of on-line analyzers, the amount of hours per day the analyzers will be run, fuel consumption of the analyzer system, and the length of time a prototype fuel is required to last. It is common practice to discard the final 10 to 20 % of any prototype tank to guard against possible fuel degradation and change in octane quality.

A2.2.3 Prototype tank construction shall meet all construction and fire codes that apply to their location. Examples of prototype tank systems are illustrated in Figs. A2.1 and A2.2.

A2.2.4 *Location of Prototype Tanks*—It is not necessary to cool prototype tanks, although it is beneficial to keep them as cool as possible. Cooling coils immersed in the prototype fuel carrying chilled water can regulate fuel temperature. Prototype tanks are normally located outside, and guarding the tanks from exposure to direct sunlight will prevent heating and fuel degradation.

A2.2.5 *Prototype Tank Plumbing*—The most important design configuration is isolation of each tank to eliminate the possibility of cross contamination of different prototype tanks. Extend the line that feeds fuel to the analyzer system 7.5 to 10 cm (3 to 4 in.) off the bottom of the tank to avoid water and sediment contamination.

A2.2.6 Additive injection and mixing facilities may need to be in place to prepare the fuel for storage and use.

A2.2.7 Fill the tank from a flowing product stream that is being analyzed and is known to have the desired octane value.

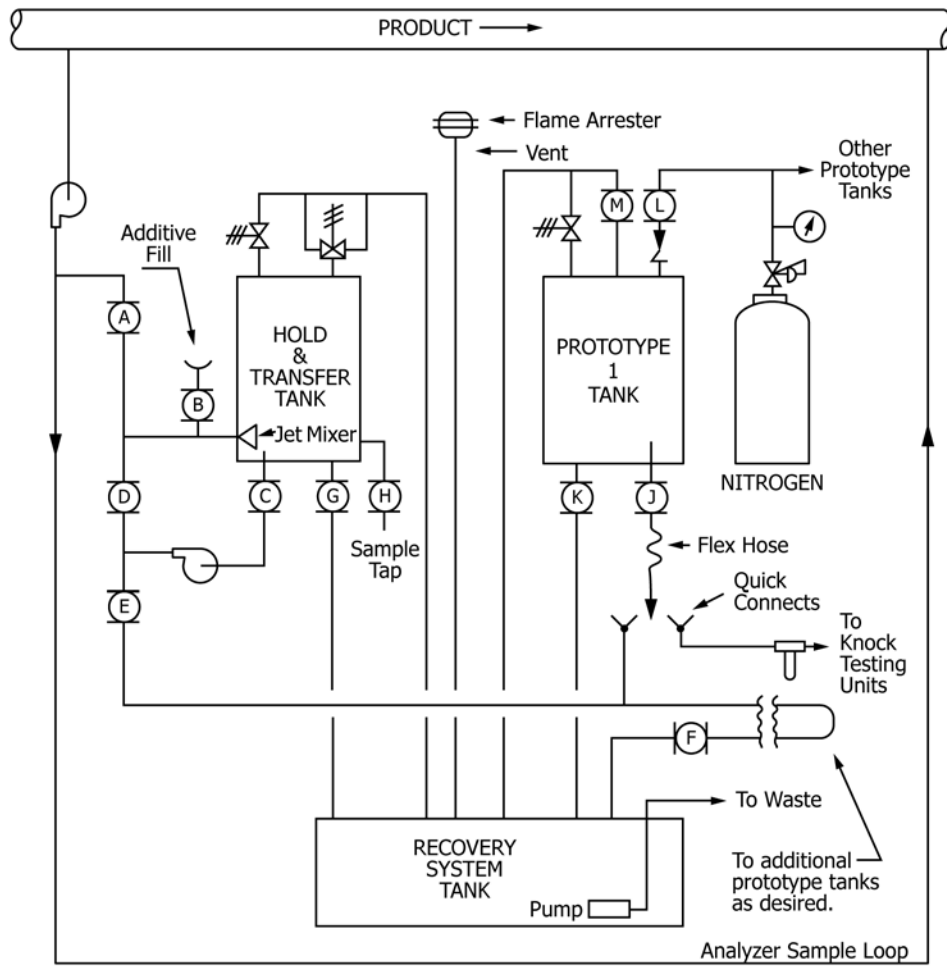

LEGEND:







- | | |
|--|--|
|  Ball valve |  Gasoline filter |
|  Pressure relief valve |  Pressure regulator |
|  Pressure-vacuum relief valve |  Check valve |

FIG. A2.1 Nitrogen Pressurized System—Block Diagram Example



LEGEND:

- | | | | |
|---|------------------------------|---|-----------------|
|  | Ball valve |  | Gasoline filter |
|  | Pressure relief valve |  | Solenoid valve |
|  | Pressure-vacuum relief valve | | |

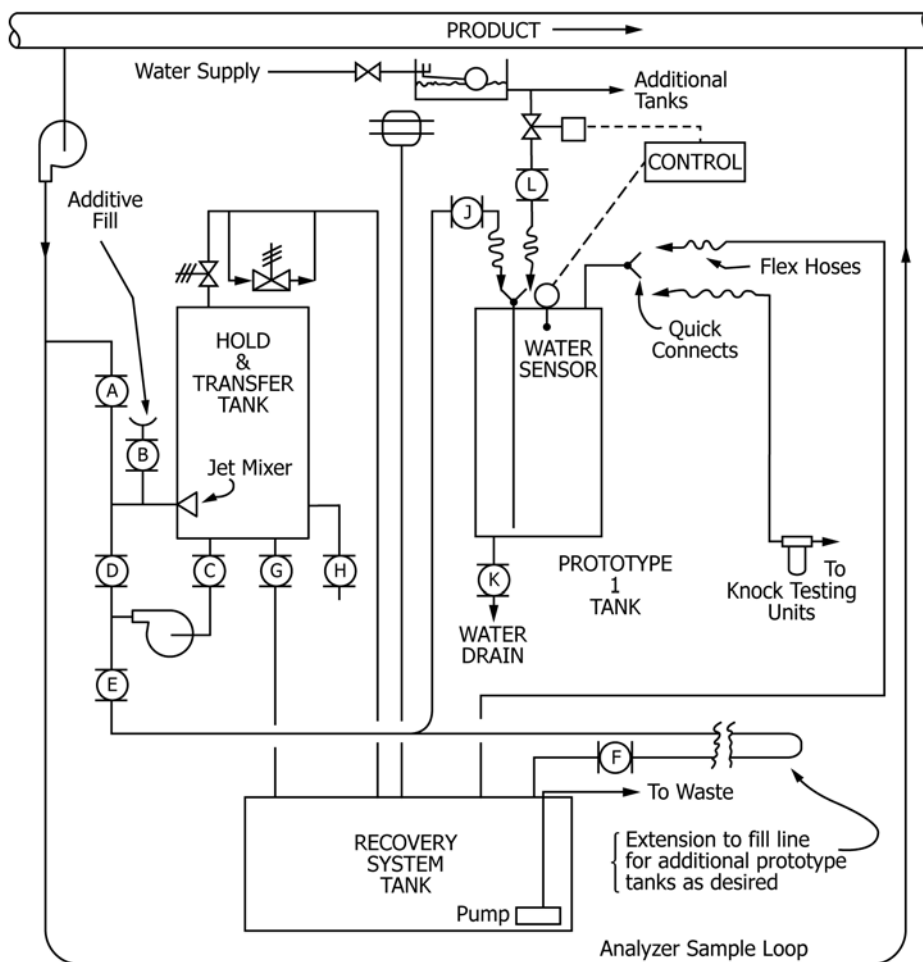
FIG. A2.2 Water Displacement System—Block Diagram Example

A3. STANDARD FUEL ACCEPTED REFERENCE VALUE (ARV) DETERMINATION

A3.1 The Accepted Reference Value (ARV) for a standard fuel is the arithmetic average of at least 16 individual octane number determinations that meet the requirements in A3.3.

A3.2 Obtain octane number (O.N.) determinations on different engines by different operators under reproducibility conditions. Ideally, use engines in different laboratories, but under no circumstance use more than two engines from the same laboratory.

A3.2.1 All procedures and equipment shall conform to the requirements of Test Method D2699 and Test Method D2700.

A3.3 Calculation of the Octane Number ARV:

A3.3.1 Assess all candidate results for calculating the ARV using the GESD technique in accordance with ASTM Research Report RR:D02-1481.⁶ Do not use results identified as outliers to calculate the ARV.

A3.3.1.1 Assess all results used to calculate the ARV for normality at a 1 % significance level in accordance with the Anderson-Darling (A-D) technique in Test Method D6299.

A3.3.2 Tabulate all the non-rejected data confirming there are at least 16 individual O.N. results.

⁶ Supporting data have been filed at ASTM International Headquarters and may be obtained by requesting Research Report RR:D02-1481.

NOTE A3.1—If there are less than 16 results, obtain additional test results on the sample to increase the number of valid results above the minimum number.

A3.3.2.1 Sum all the results.

A3.3.2.2 Divide the sum of the non-rejected results by the number of results, and record the value to the nearest one-hundredth of an octane number.

A3.3.3 *Standard Deviation:*

A3.3.3.1 Calculate the delta from the average for each result.

A3.3.3.2 Square each delta and obtain the sum of the squares.

A3.3.3.3 Determine the variance by dividing the sum of the squares of the deltas by (number of results – 1).

A3.3.3.4 Determine the standard deviation by taking the square root of the variance.

A3.3.3.5 Record the standard deviation with the ARV.

A4. PROTOTYPE FUEL OCTANE VALUE DETERMINATIONS

A4.1 Obtain prototype fuel octane value determinations by direct match comparisons with a standard fuel that has an ARV that is within ± 0.5 of the prototype candidate O.N.

A4.1.1 For each prototype calibration, an unopened standard fuel can or standard fuel drawn from a piston type or water displacement system is to be used.

A4.2 Perform at least 10 individual comparisons, with one comparison consisting of one standard fuel K.I. or C.R. and one prototype candidate K.I. or C.R.

A4.3 Perform all required comparisons on a single knock testing unit or on multiple knock testing units.

A4.3.1 If the comparisons are made on multiple knock testing units, each unit shall generate at least 10 individual comparisons as in accordance with A4.5 and then calculate the O.N. in accordance with A4.6 before the result of each unit is averaged to determine the fuel octane value.

A4.4 Procedures and equipment shall meet all the requirements in this test method.

A4.4.1 Introduce the prototype and standard fuel to the knock testing unit critical carburetor components at the same nominal temperature. This temperature shall be greater than 0°C (32°F) but not exceed 10°C (50°F).

A4.5 *Operating Procedures for Direct Match Comparison:*

A4.5.1 Operate the engine on fuel for approximately 1 h to ensure that all critical variables are stable. During the final 10 min of this warm-up period, operate the engine on the standard fuel at a fuel-air ratio set for maximum K.I.

A4.5.1.1 Check that all engine operating conditions are in compliance and equilibrated.

A4.5.2 Accurately establish the knock intensity or compression ratio units per octane number. For automated equipment,

follow the manufacturer's operating procedures to ensure proper instrument span setting.

A4.5.3 Adjust the fuel-air ratio for maximum knock intensity on the prototype candidate. It is mandatory that each fuel be operated at its independently determined fuel-air ratio.

A4.5.4 Keep the operating time on each of the fuels the same, regardless of whether manual or automated evaluation is used. There shall be sufficient operating time for the engine to reach a stable reading on each of the fuels. The minimum time for each fuel operating period is 4 min.

A4.5.4.1 Obtain the values by manual operation of a CFR engine or through the use of any analytical measurement systems that display K.I. or C.R. readings or calculate Δ O.N.

A4.5.4.2 Omit the first comparisons from the calculations if the analyzer system needs time for sequencing conditions to stabilize.

A4.5.4.3 Record a minimum of 10 standard fuel and 10 prototype fuel maximum knock intensity readings or compression ratio readings or Δ O.N. to the nearest hundredth for each pair.

(I) If knock intensity readings or compression ratio readings were recorded, convert to Δ O.N. to the nearest hundredth for each pair; use Section 13 as a guide.

A4.6 *Calculation of Prototype Octane Number:*

A4.6.1 Tabulate the Δ O.N. values, prototype minus standard fuel, and their algebraic sign.

A4.6.1.1 Sum all the results.

A4.6.1.2 Divide the sum of the results by the number of results, and record the value to the nearest one-hundredth of an octane number.

A4.6.2 Algebraically add the standard fuel ARV to the average Δ O.N. to establish the average octane number of the prototype fuel:

$$\text{Prototype O.N.} = \text{Standard fuel O.N.} + \text{Average } \Delta \text{O.N.}$$

APPENDIXES
(Nonmandatory Information)
X1. INTERPRETATION OF DELTA OCTANE NUMBER RESULTS

X1.1 *Monitoring Process Stream*—Use the Δ O.N. to represent how far a process stream deviates from the desired quality. This difference between the current and expected quality can result in a product not meeting specification or a loss in profitability. Process control programs can utilize the analyzer inputs to change the manufacturing process to bring the production quality back to the desired quality.

X1.2 *Conversion of Δ O.N. Signals to Absolute Octane Numbers*—Convert the Δ O.N. to a research or motor octane number by adding the Δ O.N. to the comparison reference fuel

octane number. This value is then the octane number of the stream sample fuel:

$$\text{Stream sample fuel O.N.} = \text{CRF O.N.} + \Delta\text{O.N.}$$

X1.3 *Determining Batch Average Octane Number Using Cumulative Flow Proportioned Average Property Value Technique*—Use stream sample fuel O.N. in conjunction with production flow information to calculate an estimated batch quality using Practice **D6624**.

X2. KNOCK TESTING UNIT MAINTENANCE GUIDE

X2.1 A routine knock testing unit preventative maintenance schedule is given below as a guide. For complete details on routine engine maintenance, refer to the CFR F-1 & F-2 manual.

X2.1.1 *Daily Checks:*

X2.1.1.1 Coolant level.

X2.1.1.2 Oil level, temperature, and pressure.

X2.1.1.3 Crankcase vacuum.

X2.1.1.4 Intake air temperature and mixture temperature for MON method.

X2.1.1.5 Coolant water pressure or flow.

X2.1.2 *Weekly Service:*

X2.1.2.1 Drain crankcase oil and refill.

X2.1.2.2 Clean or replace spark plug (gap at 0.51 ± 0.127 mm (0.020 ± 0.005 in.)).

X2.1.2.3 Check ignition breaker points (gap at 0.51 mm (0.020 in.)).

X2.1.2.4 Check ignition timing and set as required.

X2.1.2.5 Check valve clearances, and set as required (0.20 ± 0.025 mm (0.008 ± 0.001 in.) measured hot).

X2.1.3 Carbon blast the intake port, exhaust port, and combustion chamber, and scrape deposits as required.

X2.1.4 *Monthly Service:*

X2.1.4.1 Change oil filter element.

X2.1.4.2 Check fuel filters; change as required.

X2.1.4.3 Clean and inspect crankcase breather.

X2.1.4.4 Check basic cylinder height setting.

X2.1.4.5 Check ice tower screen and drain, or check the refrigeration unit's coolant condition.

X3. UNDERSTANDING THE PRECISION ASSOCIATED WITH THE OCTANE NUMBER (O.N.) AND DELTA OCTANE NUMBER (Δ O.N.) GENERATED BY THIS TEST METHOD UNDER VARIOUS CONDITIONS

X3.1 *Single Knock Testing Unit, Single PRODUCT O.N.:*

X3.1.1 Qualitatively speaking, the overall precision of product octane number data obtained via this test method using a single knock testing unit is made up of three parts. These are the precision of the standard fuel reference value, the proto fuel reference value, and the product-prototype comparison (Δ O.N.) data.

X3.1.2 Quantitatively speaking, the variance (σ^2) of product octane numbers (PRODUCT O.N.) produced from a SINGLE system via this test method, relative to the “expected” octane number as obtained by Test Methods **D2699** and **D2700**, can be described in terms of the variance (σ^2) associated with the standard fuel value, proto fuel value, and the Δ O.N. value as follows:

X3.2 *Terms and Symbols:*

X3.2.1 Δ O.N.—a single result representing the difference in octane number between two fuels as measured by one comparator system in one comparison cycle.

X3.2.2 Δ -bar,O.N.—the average of n successive Δ O.N. results, obtained under repeatability conditions.

X3.2.3 STANDARD FUEL VALUE—the average of L results from Practices **D6299** and **D6300** for a fuel, results obtained under ASTM reproducibility conditions as per **Annex A3**.

X3.2.4 PROTO FUEL VALUE—the octane number assigned to the proto fuel candidate being compared to the standard fuel by a single comparator system, calculated per **Annex A4**:

PROTO FUEL VALUE = STANDARD FUEL VALUE + Δ - bar, O.N.

X3.2.5 PRODUCT O.N.—the single octane number assigned to the fuel (product) being compared to the proto fuel, calculated per following:

$$\text{PRODUCT O.N.} = \text{PROTO FUEL VALUE} + \Delta \text{O.N.}$$

X3.2.6 $\sigma^2_{\text{STANDARD FUEL VALUE}}$ —variance of standard fuel value relative to “expected” octane number.

X3.2.7 $\sigma^2_{\text{PROTO FUEL VALUE}}$ —variance of the proto fuel value relative to “expected” octane number.

X3.2.8 $\sigma^2_{(\text{PRODUCT O.N.})}$ —variance of product octane numbers relative to “expected” octane number.

X3.2.9 $\sigma^2_{(\Delta \text{O.N.})}$ —variance of the ΔO.N. measurements using a single knock testing unit relative to the expected ΔO.N. of the two fuels.

X3.2.10 $\sigma^2_{(\Delta\text{-bar, O.N.})}$ —variance of the average of *n* successive ΔO.N.’s obtained using a single knock test unit relative to the expected ΔO.N. of the two fuels.

X3.2.11 $\sigma^2_{(\text{FPAPV})}$ —variance of the FPAPV octane numbers relative to “expected” octane number where FPAPV is calculated in accordance with Practice D6624.

NOTE X3.1—“Expected” octane number is a hypothesized value defined as the value towards which the average of *N* single results (obtained by Test Method D2699 or Test Method D2700 under ASTM reproducibility conditions) tends, as *N* becomes very large.

NOTE X3.2—Expected ΔO.N. of two fuels is defined as: (expected octane number of fuel A - expected octane number of fuel B)

X3.3 Variance of ΔO.N. Measurements Using a Single Knock Testing Unit ($\sigma^2_{(\Delta \text{O.N.})}$)—This is a measure of the variation of a single ΔO.N. value around the expected ΔO.N. of two fuels being measured. This variation includes the combined effect of short and long term variation of the octane comparator system in measuring the ΔO.N. of the two fuels. It can be expressed statistically as follows:

$$\sigma^2_{(\Delta \text{O.N.})} = \sigma^2_{(\text{COMP, long term})} + \sigma^2_{(\text{COMP, short term})} \quad (\text{X3.1})$$

where:

$\sigma^2_{(\text{COMP}_{\text{short term}})}$ = random variation of the ΔO.N. values observed under ASTM repeatability conditions, and

$\sigma^2_{(\text{COMP}_{\text{long term}})}$ = random variation of the COMPARATOR measurement process under site precision conditions that are over and above the repeatability variation. This variation represent the combined effects from multiple factors that vary randomly, and independently, at a much slower rate. Examples of these factors are: set up of the process prior to usage, equipment calibration, equipment conditions, environmental conditions.

X3.4 Variance of Δ-bar, O.N. Measurements Using a Single Knock Testing Unit ($\sigma^2_{(\Delta\text{-bar, O.N.})}$)—This represents the variation of the average of *n* successive ΔO.N. results relative to the expected ΔO.N. of the two fuels. Since its determined under ASTM repeatability conditions, only the short term component

of the variation can benefit from the reduction due to averaging per Central Limiting Theorem. It can be expressed statistically as follows:

$$\sigma^2_{(\Delta\text{-bar, O.N.})} = \sigma^2_{(\text{COMP, long term})} + \sigma^2_{(\text{COMP, short term})} \div n \quad (\text{X3.2})$$

X3.5 Variance of the Standard Fuel Value ($\sigma^2_{\text{STANDARD FUEL VALUE}}$)—This represents the variation of the standard fuel value relative to its expected octane value. It can be expressed statistically as follows:

$$\sigma^2_{(\text{STANDARD FUEL VALUE})} = \sigma^2_{(\text{D2699 or D2700 reproducibility variance})} \div L \quad (\text{X3.3})$$

X3.6 Variance of the Proto Fuel Value ($\sigma^2_{\text{PROTO FUEL VALUE}}$)— This represents the variation of the proto fuel octane number value relative to its expected octane value. It can be expressed statistically as follows:

$$\sigma^2_{(\text{PROTO FUEL VALUE})} = \sigma^2_{(\text{STANDARD FUEL VALUE})} + \sigma^2_{(\Delta\text{-bar, O.N.})} \quad (\text{X3.4})$$

Substituting Eq X3.2, Eq X3.3, into Eq X3.4:

$$\begin{aligned} \sigma^2_{(\text{PROTO FUEL VALUE})} &= \sigma^2_{(\text{D2699 or D2700 reproducibility variance})} \div L \\ &+ \sigma^2_{(\text{COMP, long term})} + \sigma^2_{(\text{COMP, short term})} \div n \end{aligned} \quad (\text{X3.5})$$

where:

n = number of ΔO.N. values used to calculate the ΔO.N.-bar value which is then added to the Standard Fuel ARV.

X3.7 Variance of a Product O.N. ($\sigma^2_{\text{PRODUCT O.N.}}$)—This represents the variation of a single product (fuel) octane number relative to its expected octane value. It can be expressed statistically as follows:

$$\sigma^2_{(\text{PRODUCT O.N.})} = \sigma^2_{(\text{PROTO FUEL VALUE})} + \sigma^2_{(\Delta \text{O.N.})} \quad (\text{X3.6})$$

Substituting Eq X3.5 into Eq X3.6:

$$\begin{aligned} \sigma^2_{(\text{PRODUCT O.N.})} &= \sigma^2_{(\text{D2699 or D2700 reproducibility variance})} \div L + \sigma^2_{(\text{COMP, long term})} \\ &+ \sigma^2_{(\text{COMP, short term})} \div n + \sigma^2_{(\text{COMP, long term})} + \sigma^2_{(\text{COMP, short term})} \\ &= \sigma^2_{(\text{D2699 or D2700 reproducibility variance})} \div L + 2\sigma^2_{(\text{COMP, long term})} \\ &+ \sigma^2_{(\text{COMP, short term})} + \sigma^2_{(\text{COMP, short term})} \div n \end{aligned} \quad (\text{X3.7})$$

X3.7.1 Using Eq X3.7, and a SINGLE ΔO.N., a confidence interval that in 95 out of 100 cases will contain the “true octane value” can be constructed as follows:

$$95\% \text{ confidence interval} = \text{product O.N.} \pm \sigma^2_{(\text{PRODUCT O.N.})}$$

X3.8 Single System, FPAPV:

X3.8.1 When a FPAPV value, calculated using the O.N. values from this test method and per Practice D6624, and this FPAPV is used to estimate the O.N. quality of a batch, the precision of this point-estimate can be quantified using Eq X3.7 as follows:

$$\begin{aligned} \sigma^2_{(\text{FPAPV})} &= \sigma^2_{(\text{D2699 or D2700 reproducibility variance})} \div L + 2\sigma^2_{(\text{COMP, long term})} \\ &+ \sigma^2_{(\text{COMP, short term})} \div m + \sigma^2_{(\text{COMP, short term})} \div n \end{aligned} \quad (\text{X3.8})$$

where:

m = number of ΔO.N. values used to compute FPAPV, and

n = number of $\Delta O.N.$ values used to determine the O.N. of the proto fuel, based on one comparator.

X3.8.2 Using the Eq X3.8, and, a FPAPV value, a confidence interval that in 95 out of 100 cases will contain the 'true octane value' for the product can be constructed as follows:

$$95\% \text{ confidence interval} = \text{FPAPV} \pm 2(\sigma_{(\text{FPAPV})}^2)$$

X3.9 How to Estimate $\sigma_{(\Delta O.N.)}^2$:

X3.9.1 This can be estimated using data obtained from repeated executions of the procedures outlined in the System Checkout section, over a long time horizon, under site precision conditions (see Note X3.3), on the same fuel pair. The fuel pair need not have an expected $\Delta O.N.$ assigned by Test Method D2699 or Test Method D2700 for this purpose. This procedure will be referred to as the QC checkout procedure, to differen-

tiate it from the System Checkout procedure for system qualification. Three control charts can be used:

X3.9.1.1 Range-chart on the variation of results within each QC checkout;

X3.9.1.2 I-chart on each QC checkout average;

X3.9.1.3 MR chart on the results in X3.9.1.2 from checkout to checkout.

NOTE X3.3—See Practice D6299 for detailed control chart instructions and definitions.

X3.10 The following equations are applicable for $n = 5$, where n represents the number of octane values used to calculate the range and QC checkout average.

$$\sigma_{(\text{COMP_short term})}^2 = R - \text{bar}/5.26$$

$$\sigma_{(\text{COMP_long term})}^2 = [\text{MR} - \text{bar}/1.128]^2 - \sigma_{(\text{COMP_short term})}^2 \div n$$

SUMMARY OF CHANGES

Subcommittee D02.01 has identified the location of selected changes to this standard since the last issue (D2885 – 10a) that may impact the use of this standard. (Approved June 15, 2013.)

(1) Removed reference to storage temperature in A2.1.4; added language to store bulk receivers and working containers away from direct sunlight.

ASTM International takes no position respecting the validity of any patent rights asserted in connection with any item mentioned in this standard. Users of this standard are expressly advised that determination of the validity of any such patent rights, and the risk of infringement of such rights, are entirely their own responsibility.

This standard is subject to revision at any time by the responsible technical committee and must be reviewed every five years and if not revised, either reapproved or withdrawn. Your comments are invited either for revision of this standard or for additional standards and should be addressed to ASTM International Headquarters. Your comments will receive careful consideration at a meeting of the responsible technical committee, which you may attend. If you feel that your comments have not received a fair hearing you should make your views known to the ASTM Committee on Standards, at the address shown below.

This standard is copyrighted by ASTM International, 100 Barr Harbor Drive, PO Box C700, West Conshohocken, PA 19428-2959, United States. Individual reprints (single or multiple copies) of this standard may be obtained by contacting ASTM at the above address or at 610-832-9585 (phone), 610-832-9555 (fax), or service@astm.org (e-mail); or through the ASTM website (www.astm.org). Permission rights to photocopy the standard may also be secured from the Copyright Clearance Center, 222 Rosewood Drive, Danvers, MA 01923, Tel: (978) 646-2600; http://www.copyright.com/