



Designation: D2867 – 17

Standard Test Methods for Moisture in Activated Carbon¹

This standard is issued under the fixed designation D2867; the number immediately following the designation indicates the year of original adoption or, in the case of revision, the year of last revision. A number in parentheses indicates the year of last reapproval. A superscript epsilon (ϵ) indicates an editorial change since the last revision or reapproval.

This standard has been approved for use by agencies of the U.S. Department of Defense.

1. Scope

1.1 These test methods provide two procedures for the determination of the moisture content of activated carbon.² The procedures may also be used to dry samples required for other tests. The oven drying method is used when water is the only volatile material present and is in significant quantities, and the activated carbon is not heat sensitive (some activated carbons can ignite spontaneously at temperatures as low as 150 °C). The xylene extraction method is used when a carbon is known or suspected to be heat sensitive or to contain nonwater-miscible organic compounds instead of or in addition to water. The oven drying method described in these test methods may be used as the reference for development of instrumental techniques for moisture determination in activated carbon.

1.2 The values stated in SI units are to be regarded as standard. No other units of measurement are included in this standard.

1.3 *This standard does not purport to address all of the safety concerns, if any, associated with its use. It is the responsibility of the user of this standard to establish appropriate safety and health practices and determine the applicability of regulatory limitations prior to use.*

1.4 *This international standard was developed in accordance with internationally recognized principles on standardization established in the Decision on Principles for the Development of International Standards, Guides and Recommendations issued by the World Trade Organization Technical Barriers to Trade (TBT) Committee.*

¹ These test methods are under the jurisdiction of ASTM Committee D28 on Activated Carbon and are the direct responsibility of Subcommittee D28.04 on Gas Phase Evaluation Tests.

Current edition approved July 1, 2017. Published July 2017. Originally approved in 1970. Last previous edition approved in 2014 as D2867–09 (2014). DOI: 10.1520/D2867-17.

² The moisture balance method has been used in industry when water is the only volatile material present and is in significant quantities and when the activated carbon is not heat sensitive. A precision and bias statement for the moisture balance method has not been developed by ASTM. Values obtained using this technique should be properly correlated to one of the documented methods described in this standard.

2. Referenced Documents

2.1 ASTM Standards:³

E177 Practice for Use of the Terms Precision and Bias in ASTM Test Methods

E691 Practice for Conducting an Interlaboratory Study to Determine the Precision of a Test Method

3. Summary of Test Methods

3.1 *Oven Drying Test Method*—A sample of carbon is put into a dry, closed capsule (of known weight) and weighed accurately. The capsule is opened and placed with the lid in a preheated oven. The sample is dried to constant weight then removed from the oven and with the capsule closed, cooled to ambient temperature. The closed capsule is weighed again accurately. The weight loss is expressed as a percentage of the weight of the original sample.

3.2 *Xylene Extraction Test Method*—A known, accurate weight of carbon is put into a boiling flask. A known volume of xylene is added to the flask and the flask is then connected to a water trap. A hot plate is used to heat the xylene until boiling. The temperature is controlled to allow steady reflux. Reflux continues until no further water can be collected in the trap. The weight of water collected is expressed as a percentage of the weight of the original sample.

4. Significance and Use

4.1 The moisture content of activated carbon is often required to define and express its properties in relation to the net weight of the carbon.

4.2 The moisture content of activated carbon packed in typical shipping containers will usually increase during transportation and storage. Users of activated carbon in applications where low moisture content is important should be aware of this effect.

³ For referenced ASTM standards, visit the ASTM website, www.astm.org, or contact ASTM Customer Service at service@astm.org. For *Annual Book of ASTM Standards* volume information, refer to the standard's Document Summary page on the ASTM website.

OVEN DRYING METHOD

5. Apparatus

5.1 *Moisture Oven*—Most commercial, electrically heated, forced-circulation drying ovens capable of temperature regulation between 145 and 155 °C may be used.

5.2 *Capsules with Covers*—Low-form glass weighing bottles with ground-glass stoppers or seamless metal boxes with covers may be used. They should be as shallow as possible, consistent with convenient handling.

5.3 *Desiccator*.

6. Materials

6.1 *Desiccant*—Anhydrous calcium chloride or other suitable desiccant.

7. Procedure for Activated Carbon Passing a No. 50 Sieve

7.1 Dip out with a spoon or spatula from the sample bottle a 1- to 2-g representative sample. Put this into a predried tared capsule with lid, close and weigh at once to the nearest 0.5 mg. The depth of the carbon in the capsule must not exceed 1.25 cm.

7.2 Remove the cover and place the capsule and cover in a preheated forced-circulation oven (at 145 to 155 °C). Close the oven and dry to constant weight (3 h normally sufficient). Open the oven and cover the capsules quickly. Cool in a desiccator to ambient temperature and weigh.

8. Procedure for Activated Carbon Larger Than a No. 50 Sieve

8.1 Use a 5- to 10-g representative sample and weigh to the nearest 2 mg. Complete the determination as described in Section 7.

9. Calculation

9.1 Calculate the moisture content as follows:

$$\text{Moisture, weight \%} = [(C - D)/(C - B)] \times 100$$

where:

- B = weight of capsule with cover, g,
 C = weight of capsule with cover plus original sample, g,
 and
 D = weight of capsule with cover plus dried sample, g.

XYLENE EXTRACTION METHOD

10. Apparatus

10.1 *Boiling Flask*—A 300-mL flat-bottom Erlenmeyer flask with ground-glass joints.

10.2 *Condenser*—A 300-mm water-cooled condenser of the Allihn type with ground-glass joints.

10.3 *Drying Tube*, containing a suitable desiccant with fiberglass filter.

10.4 *Water Trap*—A Bidwell and Sterling 10-mL or a Dean and Stark receiver with ground-glass joints. The water trap

should be clean so that the shape of the meniscus at the end of the test is the same as at the beginning.

NOTE 1—The trap may be coated with a silicone resin to give a uniform meniscus. To coat the trap, first clean it with a suitable cleaner. Rinse the clean trap with a silicone resin and after draining for a few minutes, bake for 1 h at approximately 200 °C.

10.5 *Hot Plate*—An electrically heated hot plate with enclosed elements and temperature control.

11. Reagent

11.1 *Xylene*—Reagent-grade in accordance with the specifications of the Committee on Analytical Reagents of the American Chemical Society.⁴

12. Hazards

12.1 The use of hot xylene presents a continual fire hazard and suitable fire extinguishing equipment should be available.

13. Preparation of Apparatus

13.1 Clean the condenser, flask, and trap and carefully dry to ensure that it is free of water. Assemble the condenser and water trap as shown in Fig. 1.

14. Procedure

14.1 Weigh the sample bottle. Dip out with a spoon from the sample bottle 25 to 50 g of the sample. Put this into the boiling flask and reweigh the sample bottle to the nearest 0.1 g. Add 100 mL of xylene and connect the boiling flask to the water trap. For carbons having density less than 0.30 g/cm³, 200 mL of xylene should be used for a 25-g sample.

14.2 Place the hot plate under the boiling flask and heat to boiling. Adjust the temperature control so as to reflux the xylene at the rate of about 1 drop/s from the tip of the condenser. Continue to reflux until there is no further increase in the water layer in the trap over a 30-min period (from 2 to 8 h may be required).

15. Calculation

15.1 Calculate the moisture content as follows:

$$\text{Moisture, weight \%} = [V/(C - E)] \times 100$$

where:

- V = water collected, mL,
 C = initial weight of sample bottle, g, and
 E = weight of sample bottle after removing moisture sample, g.

15.2 Calculate for the correction for moisture in carbon to determine the weight of a carbon sample on the dry basis as follows:

⁴ *Reagent Chemicals, American Chemical Society Specifications*, American Chemical Society, Washington, DC. For suggestions on the testing of reagents not listed by the American Chemical Society, see *Analar Standards for Laboratory Chemicals*, BDH Ltd., Poole, Dorset, U.K., and the *United States Pharmacopeia and National Formulary*, U.S. Pharmaceutical Convention, Inc. (USPC), Rockville, MD.

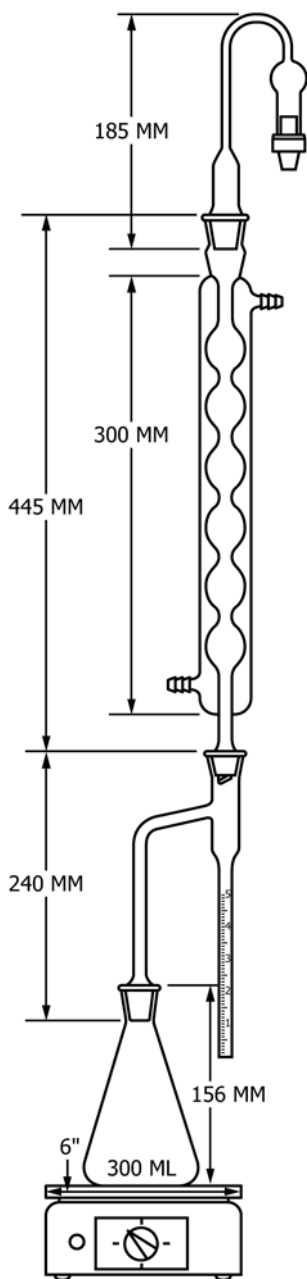

FIG. 1 Moisture Determination Apparatus

ASTM International takes no position respecting the validity of any patent rights asserted in connection with any item mentioned in this standard. Users of this standard are expressly advised that determination of the validity of any such patent rights, and the risk of infringement of such rights, are entirely their own responsibility.

This standard is subject to revision at any time by the responsible technical committee and must be reviewed every five years and if not revised, either reapproved or withdrawn. Your comments are invited either for revision of this standard or for additional standards and should be addressed to ASTM International Headquarters. Your comments will receive careful consideration at a meeting of the responsible technical committee, which you may attend. If you feel that your comments have not received a fair hearing you should make your views known to the ASTM Committee on Standards, at the address shown below.

This standard is copyrighted by ASTM International, 100 Barr Harbor Drive, PO Box C700, West Conshohocken, PA 19428-2959, United States. Individual reprints (single or multiple copies) of this standard may be obtained by contacting ASTM at the above address or at 610-832-9585 (phone), 610-832-9555 (fax), or service@astm.org (e-mail); or through the ASTM website (www.astm.org). Permission rights to photocopy the standard may also be secured from the Copyright Clearance Center, 222 Rosewood Drive, Danvers, MA 01923, Tel: (978) 646-2600; http://www.copyright.com/

$$\text{Corrected weight (dry basis)} = \quad (1)$$

$$\frac{\text{Initial weight of Carbon(undried)} \times (100\% - \% \text{ moisture from 15.1})}{(100\%)}$$

16. Precision and Bias

16.1 An interlaboratory test which included four laboratories testing in triplicate, and activated carbon samples with nominal moisture levels of 1 weight %, 5 weight %, and 12 weight %, was conducted according to Practice E691. Results of these tests yielded repeatability and reproducibility coefficients at 95 % confidence levels as listed in Table 1.

TABLE 1 Within- and Between-Laboratory Precision

Nominal Moisture, weight %	1	5	12
<i>Oven Drying Method</i>			
Repeatability Coefficient, CV % _r ^A	19	3	6
Reproducibility Coefficient, CV % _R ^A	51	13	10
<i>Xylene Extraction Method</i>			
Repeatability Coefficient, CV % _r ^A	51	5	6
Reproducibility Coefficient, CV % _R ^A	54	6	6

^A Defined in Practice E177, Section 28.

16.1.1 The high coefficients of variation for both test methods when the moisture is nominally 1 weight % suggests that values in this range be reported as “1 weight % or less.” If greater precision is needed, the amount of carbon sample can be increased over that specified in Sections 7, 8, and 14.

17. Keywords

17.1 activated carbon; moisture