



# Standard Test Method for Susceptibility of Polyethylene Bottles to Soot Accumulation<sup>1</sup>

This standard is issued under the fixed designation D 2741; the number immediately following the designation indicates the year of original adoption or, in the case of revision, the year of last revision. A number in parentheses indicates the year of last reapproval. A superscript epsilon ( $\epsilon$ ) indicates an editorial change since the last revision or reapproval.

## 1. Scope

1.1 This test method covers the determination of the relative susceptibility of polyethylene bottles to soot accumulation.

1.2 The values stated in SI units are to be regarded as standard. The values given in parentheses are for information only.

NOTE 1—There is no similar or equivalent ISO standard.

1.3 *This standard does not purport to address all of the safety concerns, if any, associated with its use. It is the responsibility of the user of this standard to establish appropriate safety and health practices and determine the applicability of regulatory limitations prior to use. Specific precautionary statements are given in Section 8 and Note 7.*

## 2. Referenced Documents

2.1 *ASTM Standards:*<sup>2</sup>

D 618 Practice for Conditioning Plastics for Testing

D 883 Terminology Relating to Plastics

E 104 Practice for Maintaining Constant Relative Humidity by Means of Aqueous Solutions

## 3. Terminology

3.1 *Definitions:*

3.1.1 Standard definitions for plastics as they appear in Terminology D 883 shall apply.

3.1.2 *soot*—the finely divided carbon rich particles resulting from incomplete combustion of an organic material.

## 4. Summary of Test Method

4.1 An electrostatic charge is generated on the bottle surface. Under controlled conditions, the charged samples are exposed in a chamber to soot created by burning toluene-wetted filter paper. Soot accumulation is rated visually by

comparing the amount of carbon particles accumulated on the bottle to that shown on a preestablished graded scale.

## 5. Significance and Use

5.1 This test method provides a useful means for determining the relative susceptibility of polyethylene bottles to accumulate soot. In particular, this test method has been found useful in evaluating antistatic additives or antistatic bottle surface treatments, or both. Experience has shown that the behavior of bottles in this test can be directly related to dust and lint accumulation under actual use conditions.

5.2 This test method provides a means of accelerating soot accumulation. However, the correlation of the results of this test method to actual use conditions must be established for each application.

5.3 Although no formal round-robin testing has been done on other types of plastics, this test method has been found useful for testing other than polyethylene plastics.<sup>3</sup>

5.4 Before proceeding with this test method, reference should be made to the specification of the material being tested. Any test specimen preparation, conditioning, dimensions, or testing parameters, or combination thereof, covered in the materials specification shall take precedence over those mentioned in this test method. If there are no material specifications, then the default conditions apply.

## 6. Apparatus

6.1 *Soot Test Chamber*, having a 0.066-m<sup>3</sup> (2.3-ft<sup>3</sup>) testing volume essentially like that shown in Fig. 1 and Fig. 2. Chambers of other design (normally larger or having multiple test chambers to allow testing of greater numbers of bottles at the same time) that provide comparable results are considered acceptable alternatives. With such chambers it is essential that the following items be sized and kept in direct proportion to the total test chamber volume:

6.1.1 Blower or fan size,

6.1.2 Amount of filter paper and toluene, and

6.1.3 Amount of drying agent if required.

<sup>1</sup> This test method is under the jurisdiction of ASTM Committee D20 on Plastics and is the direct responsibility of Subcommittee D20.20 on Plastic Products.

Current edition approved July 15, 2005. Published August 2005. Originally approved in 1968. Last previous edition approved in 2001 as D 2741 - 95 (2001).

<sup>2</sup> For referenced ASTM standards, visit the ASTM website, www.astm.org, or contact ASTM Customer Service at service@astm.org. For *Annual Book of ASTM Standards* volume information, refer to the standard's Document Summary page on the ASTM website.

<sup>3</sup> Schanzle, R. E., "New Test for Plastics Antistatics," *Modern Packaging*, MOPAA, May 1964, pp. 129, 130, and 204.

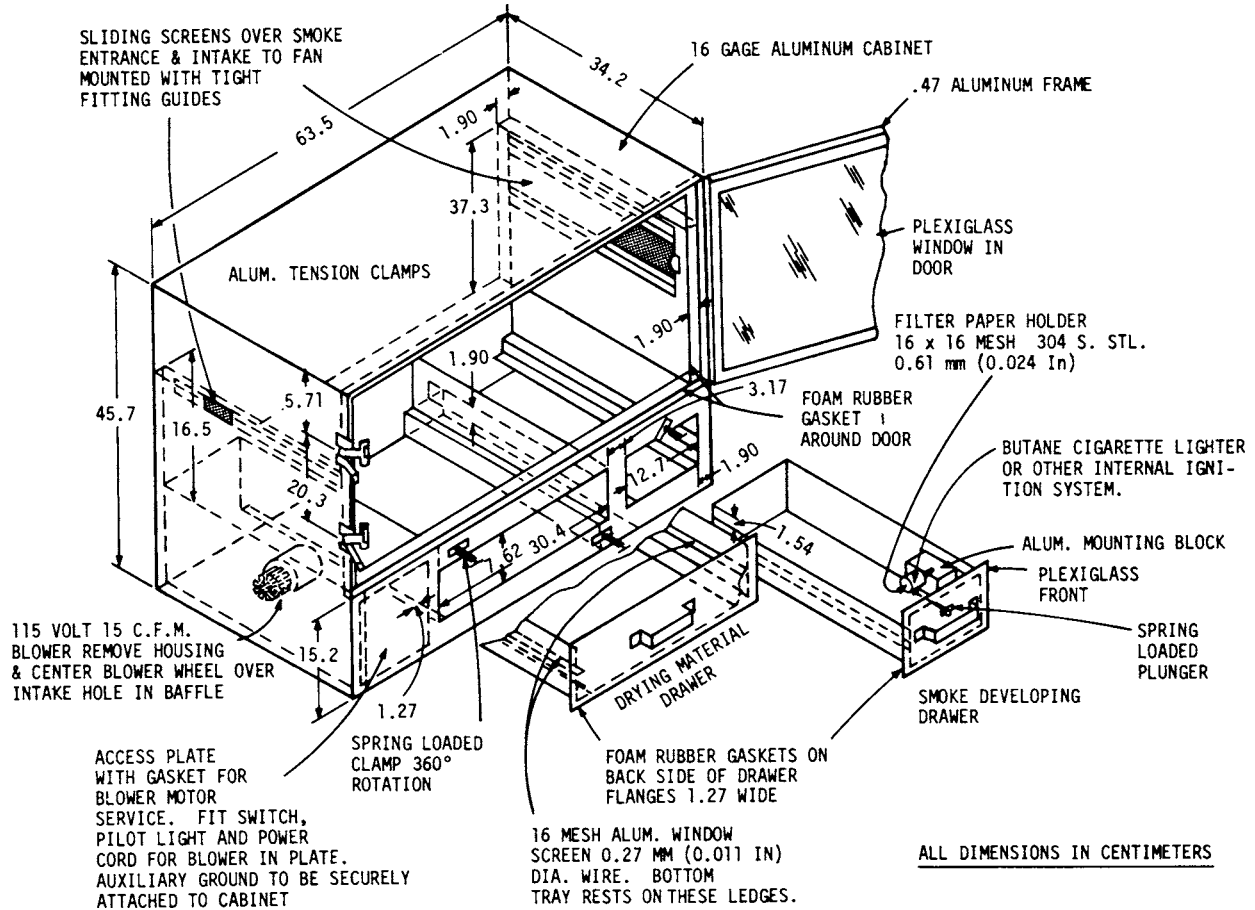

FIG. 1 Smoke Chamber for Plastic Bottle Soot Accumulation Test

6.2 *Manifold System* has been proven desirable for uniform air circulation in larger units. Experience has shown that 0.05 mL of toluene on 452 mm<sup>2</sup> of filter paper/0.028 m<sup>3</sup>(1 ft<sup>3</sup>) of test chamber volume produces a satisfactory smoke concentration. The test chamber shall be equipped with:

- 6.2.1 Means for maintaining a 15 ± 5 % relative humidity atmosphere (Note 2),
- 6.2.2 A fan or blower for air circulation,
- 6.2.3 Means for igniting toluene wetted filter paper, and
- 6.2.4 Removable 80-mesh wire screens covering test chamber inlet and outlet.

NOTE 2—The test chamber described in this procedure provides for humidity reduction by means of a chemical drying agent contained within the chamber. However, satisfactory results have been obtained by locating the chamber in a room maintained in 15 % humidity or by use of other air drying equipment.

- 6.3 *Tongs.*
- 6.4 *Dry Cloth.*
- 6.5 *Paper Towels.*<sup>4</sup>
- 6.6 *Filter Paper*, 24 mm in diameter, ashless type.
- 6.7 *Relative Humidity Indicator.*

<sup>4</sup> Kaypee Industrial Wipes, Tidi-Unidisco Co., Troy, MI, or equivalent have been found satisfactory for this purpose.

## 7. Materials

- 7.1 *Trichlorethylene*, **Warning**, see 8.1.
- 7.2 *Toluene*, **Warning**, see Section 8.
- 7.3 *Calcium Chloride*, or equivalent granules, 8-mesh.

NOTE 3—Not required when humidity reduction is obtained by other means.

## 8. Safety Precautions

8.1 Use caution when handling toluene and trichlorethylene. Small quantities may produce noticeable toxic effects if inhaled, contacted, or ingested. Have adequate ventilation.

8.2 Have a fire extinguisher nearby when handling and igniting toluene.

## 9. Test Specimens

9.1 The test specimens shall be the plastic bottles under investigation. For accurate determination of relative soot accumulation properties, all of the bottles should be of the same configuration. The specimens shall be free from visible water and dirt. Surfaces to be judged for soot accumulation properties shall not be handled either beforehand or during the performance of the test. A minimum of three specimens for each test variable is necessary.

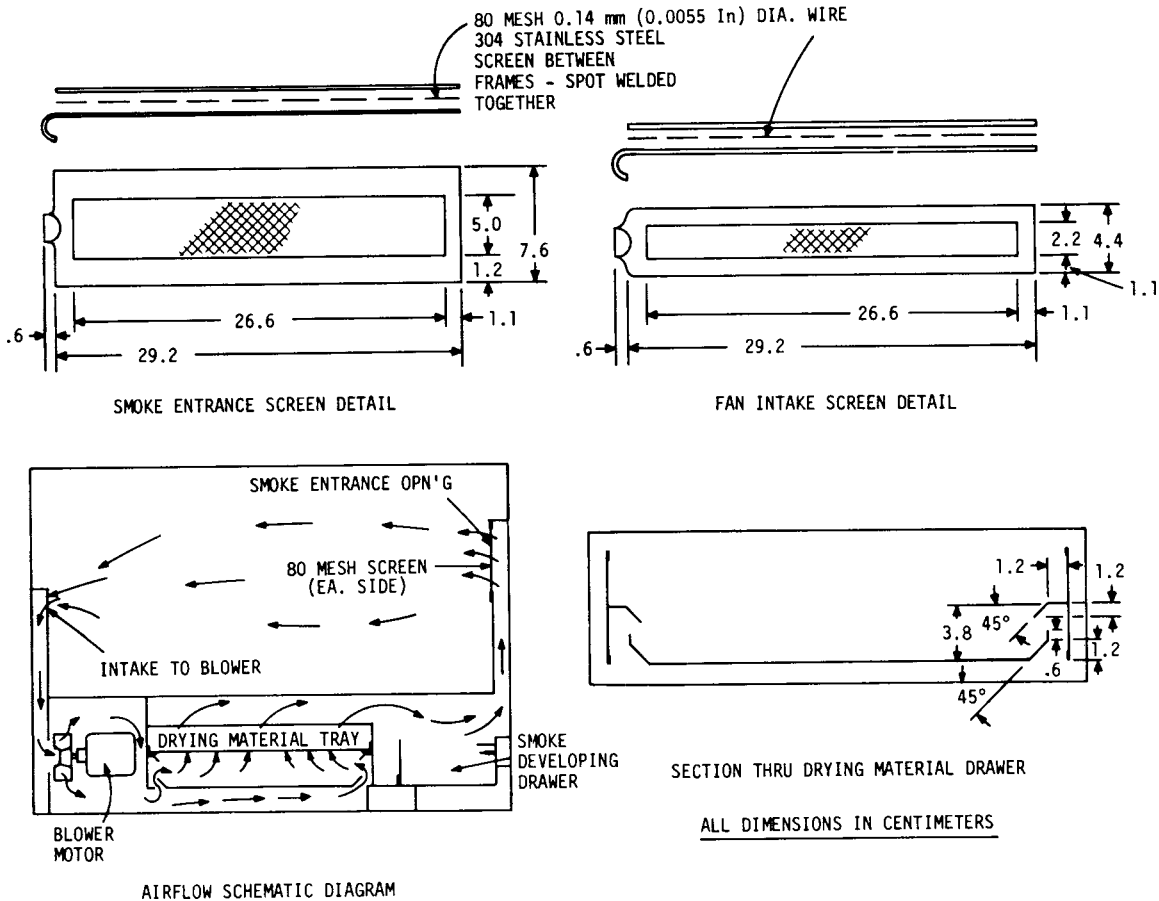

FIG. 2 Special Construction Details for Soot Accumulation Smoke Chamber

10. Calibration and Standardization

10.1 Check for test chamber tightness by sealing off smoke entrance and exit screens (Note 4), generating smoke as indicated in 12.8, and inspecting for smoke leakage into test chamber.

NOTE 4—Two-mil thick polyethylene film may be placed over the openings and held in place with pressure-sensitive tape.

10.2 With the chamber smoke entrance and exit covered just by the screens, measure the time for the smoke cloud to cross the test chamber to the chamber outlet. Adjust the blower speed to accomplish this in  $7 \pm 1$  s.

10.3 Calibrate the humidity indicator for 12 % relative humidity by storing over a saturated solution of lithium chloride at  $20 \pm 1^\circ\text{C}$  in accordance with Method C of Practice E 104. It is necessary to alternate the indicator between the 12 % humidity and a higher humidity (40 to 50 %) several times to be certain that the indicator returns to the 12 % reading accurately.

10.4 Operation of the test chamber may be checked using bottles with known soot accumulation properties.

NOTE 5—White pigmented bottles made from high-density polyethyl-

ene resin containing 0.5 % titanium dioxide and no antistatic additive and bottles made from the same material but sprayed over all with an antistatic agent can be used.

10.5 Reference Standards and Blanks:

10.5.1 Reference standards in the form of standard samples or photographs should be established as a grading scale to which tested specimens may be compared (Note 6). Bottles prepared under 10.4 may be used as extremes.

NOTE 6—The grading scale employed in round-robin testing (Fig. 3) may be used as a guide.

10.5.2 Acceptability of the reference standards shall be agreed upon between the purchaser and the seller.

11. Conditioning

11.1 Conditioning—Condition the test specimens at  $23 \pm 2^\circ\text{C}$  ( $73.4 \pm 3.6^\circ\text{F}$ ) and  $50 \pm 5$  % relative humidity for not less than 40 h prior to test in accordance with Procedure A of Practice D 618, for those tests where conditioning is required. In cases of disagreement, the tolerances shall be  $\pm 1^\circ\text{C}$  ( $\pm 1.8^\circ\text{F}$ ) and  $\pm 2$  % relative humidity.

11.2 Test Conditions—Conduct tests in the standard laboratory atmosphere of  $23 \pm 2^\circ\text{C}$  ( $73.4 \pm 3.6^\circ\text{F}$ ) and  $50 \pm 5$  %

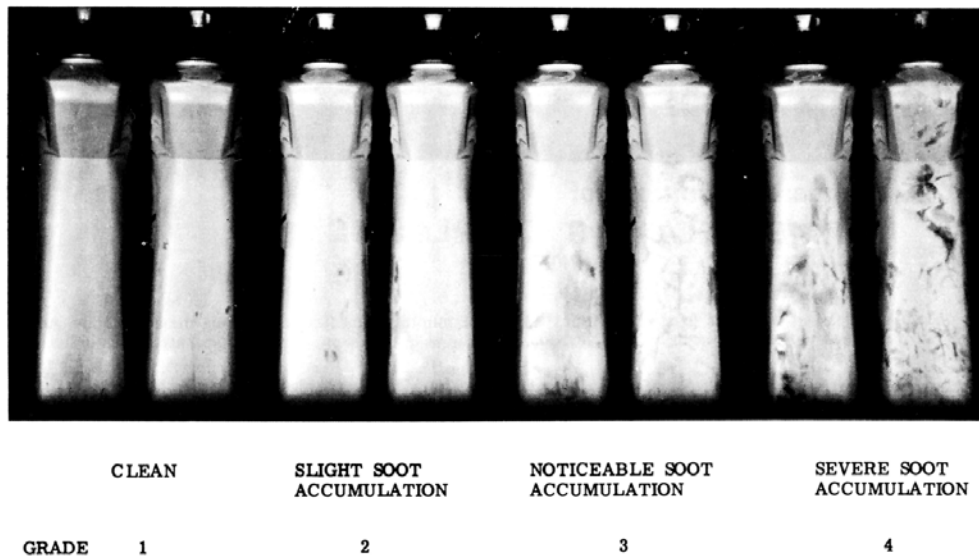

FIG. 3 Smoke Chamber Grading Scale for Polyethylene Bottles

relative humidity, unless otherwise specified in the test methods. In cases of disagreements, the tolerances shall be  $\pm 1^\circ\text{C}$  ( $\pm 1.8^\circ\text{F}$ ) and  $\pm 2\%$  relative humidity.

## 12. Procedure

12.1 Remove the wire screens from the chamber and clean them by brushing in trichlorethylene. Dry with a clean cloth. Wipe out the empty chamber with a clean dry cloth to remove all loose soot.

12.2 For the apparatus shown in Fig. 1 and Fig. 2, spread  $200 \pm 5$  g of calcium chloride on the screen in the drying drawer. If the chamber has been used previously, check the condition of the calcium chloride drying agent in the drying drawer and replace if the chamber has been left open or if the ambient humidity is extremely high. If not replaced sooner, replace the calcium chloride after every ten tests.

12.3 Close and latch all the chamber openings, start the blower, and reduce the relative humidity in the chamber to  $15 \pm 5\%$ ; turn off the blower.

12.4 Charge each bottle to be tested separately by rubbing with a paper towel. Stroke each bottle surface to be tested (Note 7) ten times in one direction starting at the top of the bottle and contacting the full panel surface as the stroke is made to the bottom of the panel. Use a new towel for each resin or surface treatment variable tested.

NOTE 7—Frequently only part of a bottle, such as an unlabeled side panel, is to be tested rather than the total bottle surface. In these instances the bottle area to be tested must be specified.

12.5 Immediately after charging, place each bottle in the chamber allowing no less than 50 mm (2 in.) between bottles or between the chamber walls and the bottles. Keep the test chamber door closed except when opened to position a charged bottle in the chamber.

12.6 Latch the chamber door. Start the blower. Maintain the chamber humidity at  $15 \pm 5\%$  for 2 h.

12.7 Turn the blower off. Wet a piece of filter paper held with tongs with 0.10 mL of toluene.<sup>5</sup> Immediately place the wetted filter paper on the holder in the combustion drawer, close the drawer, and immediately ignite the toluene using the ignition system (Note 8). Allow the filter paper to burn for  $15 \pm 1$  s; then immediately start the blower. Turn off the blower after  $7 \pm 1$  s.

NOTE 8—**Caution:** A delay in ignition could allow solvent vapors to mix with air in the chamber creating a possible explosion hazard.

NOTE 9—The time the blower is run should be sufficient to just carry the smoke cloud across the test chamber to the chamber outlet. The test is made less severe if the blower is allowed to run longer than the specified time after ignition because particles are carried past the bottles, lodging on the blower blades, lower chamber surfaces, drying agent, etc.

12.8 After  $15 \pm 1$  min, open the chamber door and immediately remove the specimens for inspection.

NOTE 10—Bottle contact time with the smoke generated affects the severity of the test results. Less contact time reduces the soot collected on the bottles, while a longer contact time increases the amount of soot collected. If desired, the bottles may be lightly sprayed with clear lacquer to preserve their appearance.

## 13. Interpretation of Results

13.1 Subjectively rate the soot accumulation on the specimens by comparison with the grading scale established. Soot accumulation may be rated as none, slight, moderate, or severe.

## 14. Report

14.1 Report the following information:

14.1.1 Complete identification of the plastic bottles tested including source, manufacturer, type, form, date of manufacture (if internal antistatic agent employed) or date of surface treatment (if applicable), previous history, etc.,

<sup>5</sup> A hypodermic syringe has been found useful in accurately dispensing small amounts of toluene.

- 14.1.2 Purpose of test,
- 14.1.3 Atmospheric conditions during conditioning and testing,
- 14.1.4 Bottle surface or surfaces rubbed,
- 14.1.5 Degree of soot accumulation and location on the bottle surface for each bottle tested, and
- 14.1.6 Date of test.

## 15. Precision and Bias

15.1 A round-robin was conducted in which untreated bottles were compared with bottles of the same type sprayed with an antistatic agent known to be effective. Three sets, each consisting of three untreated bottles and three bottles of each level of treatment, were tested by each of five laboratories. Each laboratory rated the specimens it had against the same four-division photographic scale: Grade 1 (clean), Grade 2 (slight accumulation), Grade 3 (moderate accumulation), and Grade 4 (severe accumulation) (Fig. 3).

15.2 Interlaboratory agreement in this round-robin was very good (Table 1). However, more difficulty would be experienced in comparing containers having intermediate soot accumulation properties. The testing of additional specimens is advised in such cases.

**TABLE 1 Soot Accumulation on White Polyethylene Bottles**

Bottle Treatment	Number of Specimens Rated				Total Specimens
	Grade 1	Grade 2	Grade 3	Grade 4	
A—no additives, no surface treatment	0	0	0	45	45
B—no additives, sprayed with antistatic agent	36	7	2	0	45

15.3 Data obtained by rating specimens against a set of arbitrary standards may be analyzed statistically in the form of contingency tables.<sup>6</sup> The dependence of rating on the material type or the surface treatment or on the individual graders may be assessed.

15.4 Since there is no accepted reference method for this test method, the bias of this test method cannot be determined.

## 16. Keywords

16.1 polyethylene bottles; soot accumulation

<sup>6</sup> Mood, A. M., *Introduction to the Theory of Statistics*, McGraw-Hill Book Co., Inc., NY, p. 273.

*ASTM International takes no position respecting the validity of any patent rights asserted in connection with any item mentioned in this standard. Users of this standard are expressly advised that determination of the validity of any such patent rights, and the risk of infringement of such rights, are entirely their own responsibility.*

*This standard is subject to revision at any time by the responsible technical committee and must be reviewed every five years and if not revised, either reapproved or withdrawn. Your comments are invited either for revision of this standard or for additional standards and should be addressed to ASTM International Headquarters. Your comments will receive careful consideration at a meeting of the responsible technical committee, which you may attend. If you feel that your comments have not received a fair hearing you should make your views known to the ASTM Committee on Standards, at the address shown below.*

*This standard is copyrighted by ASTM International, 100 Barr Harbor Drive, PO Box C700, West Conshohocken, PA 19428-2959, United States. Individual reprints (single or multiple copies) of this standard may be obtained by contacting ASTM at the above address or at 610-832-9585 (phone), 610-832-9555 (fax), or service@astm.org (e-mail); or through the ASTM website (www.astm.org).*