



Standard Test Method for Unrestrained Linear Thermal Shrinkage of Plastic Film and Sheeting¹

This standard is issued under the fixed designation D2732; the number immediately following the designation indicates the year of original adoption or, in the case of revision, the year of last revision. A number in parentheses indicates the year of last reapproval. A superscript epsilon (ϵ) indicates an editorial change since the last revision or reapproval.

This standard has been approved for use by agencies of the U.S. Department of Defense.

1. Scope*

1.1 This test method covers determination of the degree of unrestrained linear thermal shrinkage at given specimen temperatures of plastic film and sheeting of 0.76 mm (0.030 in.) thickness or less. This test method does not cover shrinkage from loss of solvent in some materials.

1.2 The values stated in SI units are to be regarded as standard. The values given in parentheses are mathematical conversions to inch-pound units that are provided for information only and are not considered standard.

1.3 *This standard does not purport to address all of the safety concerns, if any, associated with its use. It is the responsibility of the user of this standard to establish appropriate safety and health practices and determine the applicability of regulatory limitations prior to use.*

NOTE 1—This standard and ISO 11501 address the same subject matter, but differ in technical content.

2. Referenced Documents

2.1 ASTM Standards:²

D618 Practice for Conditioning Plastics for Testing

D883 Terminology Relating to Plastics

D1204 Test Method for Linear Dimensional Changes of Nonrigid Thermoplastic Sheeting or Film at Elevated Temperature

E2251 Specification for Liquid-in-Glass ASTM Thermometers with Low-Hazard Precision Liquids

2.2 ISO Standard:³

ISO 11501 Determination of Dimensional Change on Heating

¹ This test method is under the jurisdiction of ASTM Committee D20 on Plastics and is the direct responsibility of Subcommittee D20.19 on Film, Sheeting, and Molded Products.

Current edition approved Dec. 1, 2014. Published December 2014. Originally approved in 1968. Last previous edition approved in 2008 as D2732 – 08. DOI: 10.1520/D2732-14.

² For referenced ASTM standards, visit the ASTM website, www.astm.org, or contact ASTM Customer Service at service@astm.org. For *Annual Book of ASTM Standards* volume information, refer to the standard's Document Summary page on the ASTM website.

³ Available from American National Standards Institute (ANSI), 25 W. 43rd St., 4th Floor, New York, NY 10036, <http://www.ansi.org>.

3. Terminology

3.1 Definitions:

3.1.1 *unrestrained linear thermal shrinkage (free shrink or shrinkage)*—the irreversible and rapid reduction in linear dimension in a specified direction occurring in film subjected to elevated temperatures under conditions where nil or negligible restraint to inhibit shrinkage is present. It is normally expressed as a percentage of the original dimension.

4. Significance and Use

4.1 As a result of the manufacturing process, internal stresses may be locked into the film which can be released by heating. The temperature at which shrinkage will occur is related to the processing techniques employed to manufacture the film and may also be related to a phase transition in the base resin. The magnitude of the shrinkage will vary with the temperature of the film.

4.2 Shrinkage of a particular material produced by a particular process may be characterized by this test method by making measurements at several temperatures through the shrinkage range of the material.

4.3 Following a characterization in a particular case, it is usually sufficient thereafter to measure shrinkage at only one selected temperature for purposes of process or quality control, or both.

5. Apparatus

5.1 *Constant-Temperature Liquid Bath*, capable of controlling accurately to $\pm 0.5^\circ\text{C}$.

5.1.1 The liquid for the bath should not plasticize or react with the specimens. Poly(ethylene glycol), glycerin, and water have been found to have wide applicability.

5.2 *Thermometer*—ASTM Thermometer S5C-11 conforming to the requirements as prescribed in Specification E2251.

5.3 *Square Metal Stamp*, 100 by 100 mm, with engraved arrow indicating machine direction of film and stamp pad and ink. (The ink should not be soluble in the bath liquid.)

NOTE 2—A metal die or template (100 by 100 mm) can be used instead of the square metal stamp.

*A Summary of Changes section appears at the end of this standard

5.4 *Free Shrink Holder*—A holder designed for test of a single specimen, such as that shown in Fig. 1 and Fig. 2. Alternatively, a holder such as that shown in Fig. 3 is capable of immersing several specimens at a time. However, checks must be made to assure that contact among the specimens does not result in errors.

5.5 *Ruler*, graduated in millimetres.

6. Test Specimen

6.1 The test specimen shall consist of 100 by 100-mm samples.

6.2 A minimum of two specimens is necessary for each test temperature.

7. Conditioning

7.1 *Conditioning*—Condition the test specimens in accordance with Procedure A of Practice D618 unless otherwise specified by agreement or the relevant ASTM material specification. In cases of disagreement, the tolerances shall be $\pm 1^\circ\text{C}$ ($\pm 1.8^\circ\text{F}$) and $\pm 5\%$ relative humidity

7.2 *Test Conditions*—Set the liquid bath temperature to within $\pm 0.5^\circ\text{C}$ of the desired temperature and allow it to stabilize.

8. Procedure

8.1 Stamp and cut out the stamped section of film. A small border of film may be left around the stamped area.

8.1.1 As an alternative method, the specimens may be cut with a die or with the aid of a template. An edge of the die may be notched to designate film direction.

8.2 Place the specimen in a free shrink holder such that it is free from contact with the edges of the holder. The holder should restrain the specimen from floating in the bath medium while allowing free circulation of the bath medium around the specimen. Multiple specimens can be tested but care should be exercised to prevent restraint between the specimens.

8.3 Observe and record the temperature of the bath before immersion of each specimen.

8.4 Immerse the specimen in the bath for 10 s or a time determined to be sufficient for the material to come to thermal

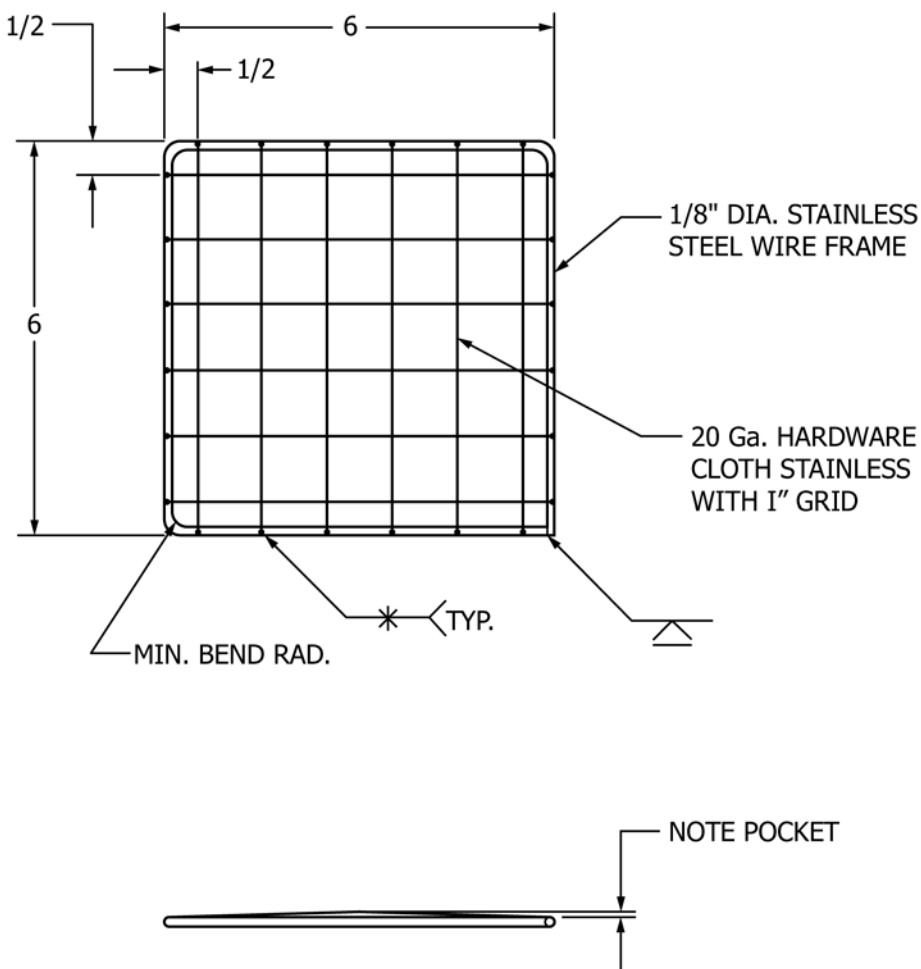

- NOTE:
1. (A) Cut hardware cloth $6\frac{1}{8}$ by $6\frac{1}{8}$.
 - (B) Form a pocket in center of cloth.
 - (C) Weld cloth to frame as shown.
 2. Two required for assembly.

FIG. 1 Construction of Top and Bottom Grid Retainers of Specimen Holder

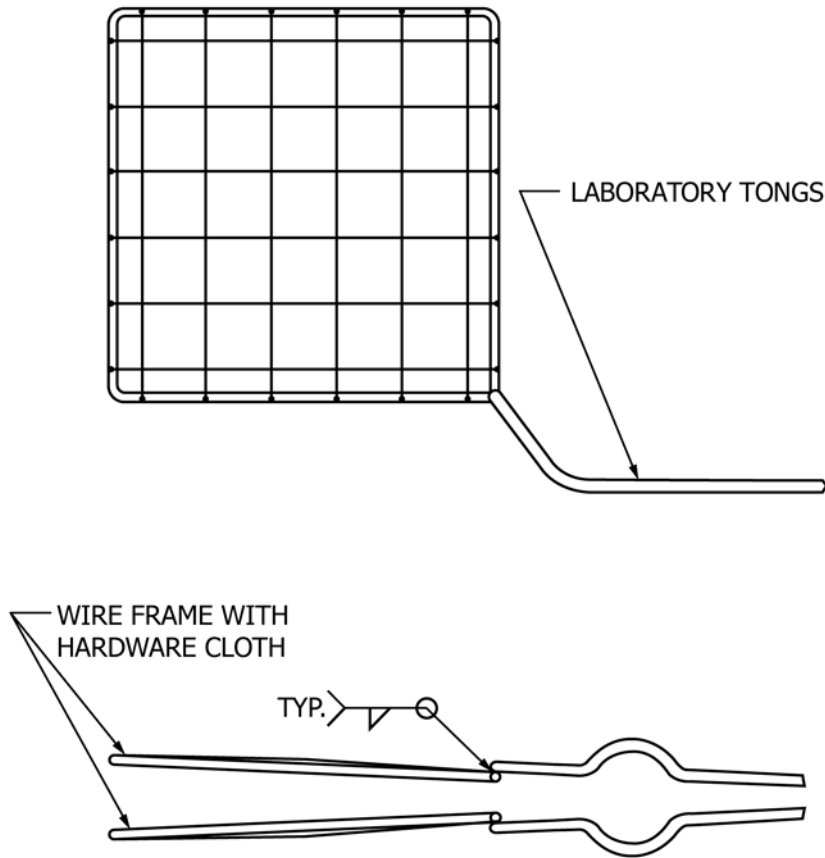

NOTE 1—Weld one wire frame to the inside of both arms of the tongs as shown.

FIG. 2 Assembly of Specimen Holder

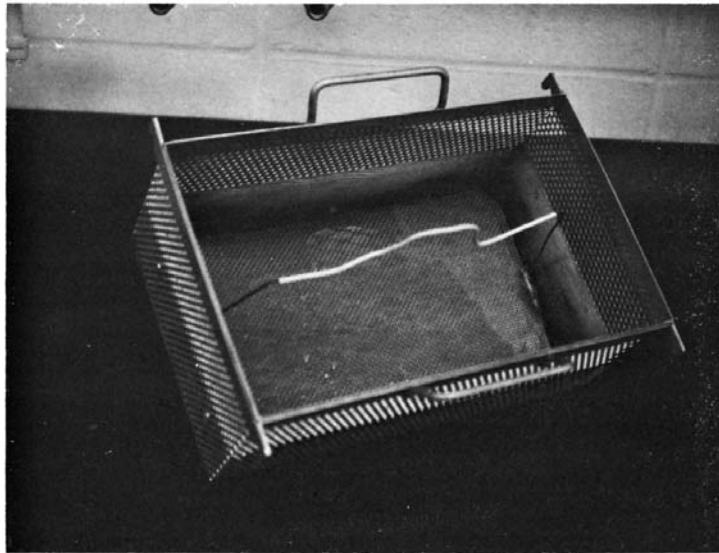

FIG. 3 Trough and Wire Basket

equilibrium and undergo maximum shrinkage. Do not hold the specimen over the bath prior to immersion, as it is capable of causing premature shrinkage or annealing, which will introduce an error.

NOTE 3—Immersion for 10 s has been determined to be generally adequate for most thermoplastics of up to 0.05 mm (0.002 in.) thickness; however, for new or thicker materials, time of immersion shall be evaluated to ensure maximum shrinkage at the temperature of interest.

8.5 Remove the specimen from the bath and quickly immerse in a liquid medium at room temperature preferably miscible with the bath medium.

8.6 After 5 s remove the specimen from the cooling medium and measure and record the linear dimensions of the specimen in both the machine (longitudinal) and transverse directions.

NOTE 4—**Caution:** Avoid stretching the specimen.

9. Calculation

9.1 Determine the percent free shrinkage for each direction as follows:

$$\text{Unrestrained linear shrinkage, \%} = [(L_0 - L_f)/L_0] \times 100 \quad (1)$$

where:

L_0 = initial length of side (100 mm), and

L_f = length of side after shrinking.

NOTE 5—If the material elongates, a negative number will result.

NOTE 6—If the original dimension is exactly 100 mm, the shrinkage may be read directly from the rule by placing the 100-mm mark on one end of the line and reading millimetres opposite the other end of the line as the percent shrinkage.

9.2 *Sample Calculations:*

$$\text{Initial length, } L_0 = 100 \text{ mm} \quad (2)$$

$$\text{Length after shrinkage, } L_f = 75 \text{ mm} \quad (3)$$

$$\text{Unrestrained linear shrinkage, \%} = [(100 - 75)/100] \times 100 = 25 \quad (4)$$

10. Report

10.1 The report shall include the following:

- 10.1.1 Average percent linear free shrinkage in both directions, machine (longitudinal) and transverse,
- 10.1.2 Bath temperature,
- 10.1.3 Complete sample identification, and
- 10.1.4 Number of specimens tested.

11. Precision and Bias

11.1 *Precision*—Round-robin tests between five locations have shown good agreement by this procedure with reproducibility as shown in Fig. 4 and Fig. 5; however, the round-robin data is unavailable to calculate the parameters for a formal precision and bias statement.

11.2 *Bias*—There are no recognized standards by which to estimate the bias of this test method.

12. Keywords

12.1 free shrink; plastics; sheeting; unrestrained linear shrinkage

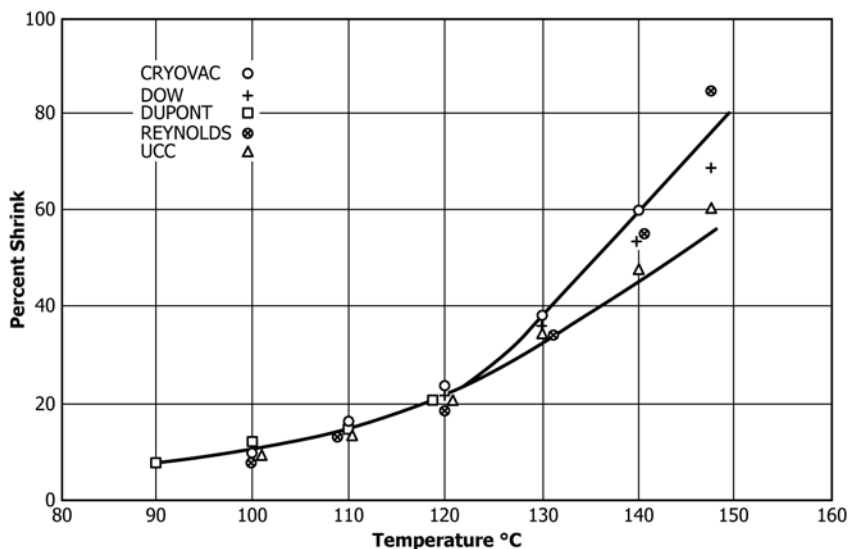

FIG. 4 Round-Robin Data for Machine-Direction Shrinkage of Biaxially-Oriented Polysulfone Sheetting

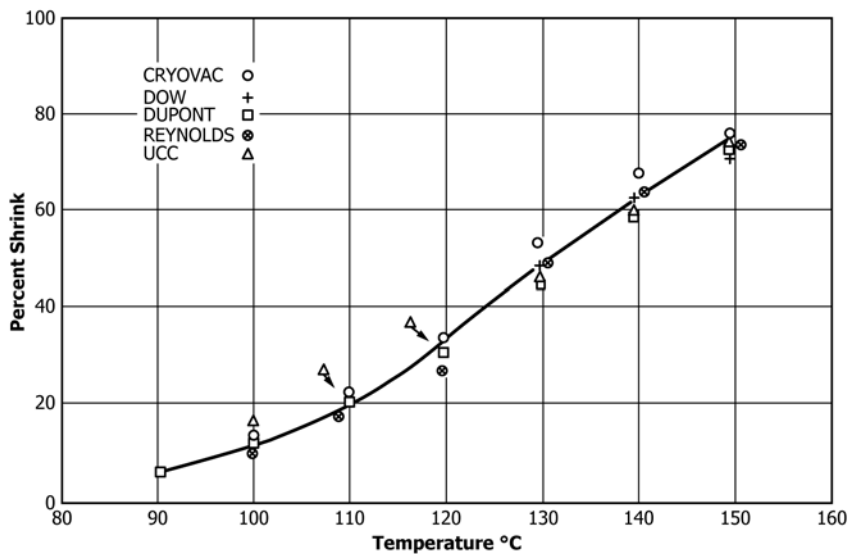

FIG. 5 Round Robin Data for Transverse-Direction Shrinkage of Biaxially-Oriented Polysulfone Sheet

SUMMARY OF CHANGES

Committee D20 has identified the location of selected changes to this standard since the last issue (D2732 - 08) that may impact the use of this standard. (December 1, 2014)

- (1) Changed reference from E1 to E2251.
- (2) Revised Sections 5, 7, and 8.
- (3) Revised ISO equivalency statement (Note 1).

ASTM International takes no position respecting the validity of any patent rights asserted in connection with any item mentioned in this standard. Users of this standard are expressly advised that determination of the validity of any such patent rights, and the risk of infringement of such rights, are entirely their own responsibility.

This standard is subject to revision at any time by the responsible technical committee and must be reviewed every five years and if not revised, either reapproved or withdrawn. Your comments are invited either for revision of this standard or for additional standards and should be addressed to ASTM International Headquarters. Your comments will receive careful consideration at a meeting of the responsible technical committee, which you may attend. If you feel that your comments have not received a fair hearing you should make your views known to the ASTM Committee on Standards, at the address shown below.

This standard is copyrighted by ASTM International, 100 Barr Harbor Drive, PO Box C700, West Conshohocken, PA 19428-2959, United States. Individual reprints (single or multiple copies) of this standard may be obtained by contacting ASTM at the above address or at 610-832-9585 (phone), 610-832-9555 (fax), or service@astm.org (e-mail); or through the ASTM website (www.astm.org). Permission rights to photocopy the standard may also be secured from the Copyright Clearance Center, 222 Rosewood Drive, Danvers, MA 01923, Tel: (978) 646-2600; http://www.copyright.com/