



Standard Practice for Heat Fusion Joining of Polyolefin Pipe and Fittings¹

This standard is issued under the fixed designation D2657; the number immediately following the designation indicates the year of original adoption or, in the case of revision, the year of last revision. A number in parentheses indicates the year of last reapproval. A superscript epsilon (ϵ) indicates an editorial change since the last revision or reapproval.

This standard has been approved for use by agencies of the U.S. Department of Defense.

1. Scope

1.1 This practice describes general procedures for making joints with polyolefin pipe and fittings (excluding polyethylene pipe and fittings) by means of heat fusion joining techniques in either a shop or field environment. These procedures are general ones. Specific instructions for heat fusion joining are obtained from product manufacturers. See Practice **F2620** for heat fusion joining of polyethylene pipe and fittings.

1.2 The techniques covered are applicable only to joining polyolefin pipe and fittings of related polymer chemistry, for example, polypropylenes to polypropylenes, or polybutylenes to polybutylenes. Material, density, and flow rate shall be taken into consideration in order to develop uniform melt viscosities and formation of a good fusion bond when joining the same material to itself or to other materials of related polymer chemistry.

1.3 Parts that are within the dimensional tolerances given in present ASTM specifications are required to produce sound joints between polyolefin pipe and fittings when using the joining techniques described in this practice.

1.4 The values stated in inch-pound units are to be regarded as standard. The values given in parentheses are mathematical conversions to SI units that are provided for information only and are not considered standard.

1.5 The text of this practice references notes, footnotes, and appendixes which provide explanatory material. These notes and footnotes (excluding those in tables and figures) shall not be considered as requirements of the practice.

1.6 *This standard does not purport to address all of the safety concerns, if any, associated with its use. It is the responsibility of the user of this standard to establish appropriate safety and health practices and determine the applicability of regulatory limitations prior to use. See specific safety precautions in 3.1.1, 5.2, 8.2.3.1, Note 8 and Note 9, and A1.1.*

¹ This practice is under the jurisdiction of ASTM Committee **F17** on Plastic Piping Systems and is the direct responsibility of Subcommittee **F17.20** on Joining.

Current edition approved Dec. 1, 2015. Published December 2015. Originally approved in 1967. Last previous edition approved in 2007 as D2657 – 07. DOI: 10.1520/D2657-07R15.

2. Referenced Documents

2.1 ASTM Standards:²

F1056 Specification for Socket Fusion Tools for Use in Socket Fusion Joining Polyethylene Pipe or Tubing and Fittings

F2620 Practice for Heat Fusion Joining of Polyethylene Pipe and Fittings

3. Summary of Practice

3.1 Heat-fusion joining uses a combination of heat and force resulting in two melted surfaces flowing together to produce a joint. Fusion bonding occurs when the joint cools below the melt temperature of the material. There is a temperature range within which any particular material is satisfactorily joined. The specific temperature used requires consideration of the properties of the specific material, and the joining environment. With Techniques II or III (**3.3.2** or **3.3.3**), there is also an appropriate force to be applied which depends upon the material, the fusion equipment being used, and fusion temperature. See Practice **F2620** for heat fusion procedure for polyethylene pipe and fittings.

3.1.1 Electrically powered heat fusion tools and equipment are usually not explosion proof. When performing heat fusion in a potentially combustible atmosphere such as in an excavation where gas is present, all electrically powered tools and equipment that will be used in the combustible atmosphere shall be disconnected from the electrical power source and operated manually to prevent explosion and fire. For the heating tool, this requires bringing the heating tool up to or slightly above temperature in a safe area, then disconnecting it from electrical power immediately before use. This procedure is limited to smaller sizes where heating is accomplished before the heating tool drops below acceptable temperature.

3.2 Adequate joint strength for testing is attained when all of the joint material cools to ambient temperature. The joint shall not be disturbed or moved until it has cooled. See Practice **F2620** for heat fusion procedure for polyethylene pipe and fittings.

² For referenced ASTM standards, visit the ASTM website, www.astm.org, or contact ASTM Customer Service at service@astm.org. For *Annual Book of ASTM Standards* volume information, refer to the standard's Document Summary page on the ASTM website.

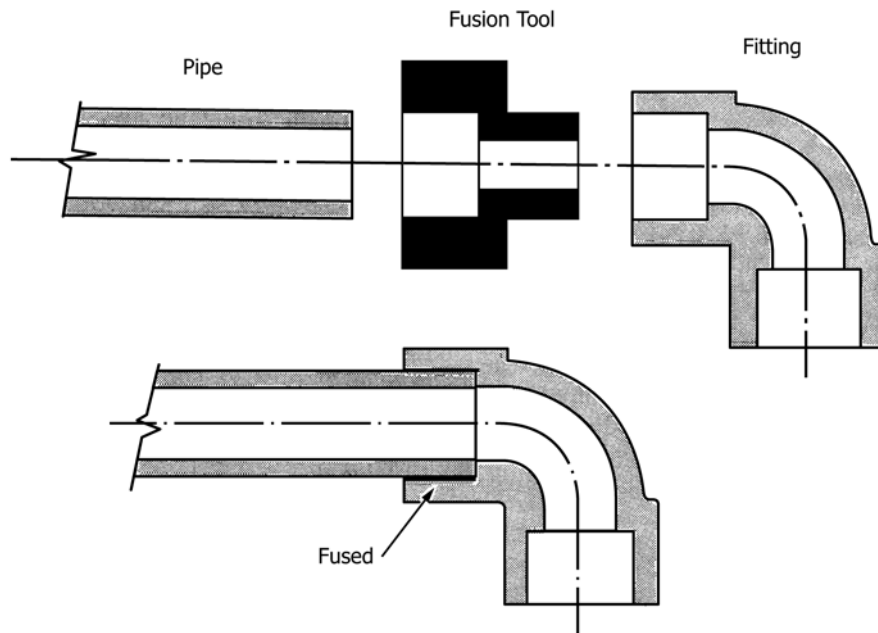

FIG. 1 Socket Fusion

NOTE 1—Polybutylene undergoes a crystalline transformation for several days after cooling below its melt temperature. Although this phenomenon has an effect on the ultimate physical properties of the material, its effect on testing of joints has not been found to be significant. If there is any question of its effect, a comparison should be made between joints that have been conditioned for different periods of time in order to establish the conditioning-time relationship.

3.3 Three fusion techniques are covered in this practice as follows: See Practice F2620 for heat fusion procedure for polyethylene pipe and fittings.

3.3.1 *Procedure 1, Socket Fusion*—The socket-fusion technique involves simultaneously heating the outside surface of a pipe end and the inside of a fitting socket, which is sized to be smaller than the smallest outside diameter of the pipe. After the proper melt has been generated at each face to be mated, the two components are joined by inserting one component into the other. See Fig. 1. The fusion bond is formed at the interface resulting from the interference fit. The melts from the two components flow together and fuse as the joint cools. Optional alignment devices are used to hold the pipe and socket fitting in longitudinal alignment during the joining process; especially with pipe sizes 3 in. IPS (89 mm) and larger.

3.3.2 *Procedure 2, Butt Fusion*—The butt-fusion technique in its simplest form consists of heating the squared ends of two pipes, a pipe and a fitting, or two fittings, by holding them against a heated plate, removing the plate when the proper melt is obtained, promptly bringing the ends together, and allowing the joint to cool while maintaining the appropriate applied force. See Fig. 2. An alignment jig shall be used to obtain and maintain suitable alignment of the ends during the fusion operation.

3.3.3 *Procedure 3, Saddle Fusion*—The saddle-fusion technique involves melting the concave surface of the base of a saddle fitting, while simultaneously melting a matching pattern on the surface of the pipe, bringing the two melted surfaces

together and allowing the joint to cool while maintaining the appropriate applied force. See Fig. 3.

4. Significance and Use

4.1 The procedures described in Sections 7, 8, and 9, when implemented using suitable equipment and procedures in either a shop or field environment, produce strong pressure-tight joints equal to the strength of the piping material. Some materials are more adaptable to one technique than another. Melt characteristics, average molecular weight and molecular weight distribution are influential factors in establishing suitable fusion parameters; therefore, consider the manufacturer's instructions in the use or development of a specific fusion procedure.

5. Operator Experience

5.1 Skill and knowledge on the part of the operator are required to obtain a good quality joint. This skill and knowledge is obtained by making joints in accordance with proven procedures under the guidance of skilled operators. Evaluate operator proficiency by testing sample joints.

5.2 The party responsible for the joining of polyolefin pipe and fittings shall ensure that detailed procedures developed in conjunction with applicable codes and regulations and the manufacturers of the pipe, fittings, and joining equipment involved, including the safety precautions to be followed, are issued before actual joining operations begin.

6. Apparatus: General Recommendations

6.1 *Heating Tool*—The tool may be heated by gas or electricity. Gas-fired heaters for 2 in. IPS and smaller socket and butt fusion joints only, shall have heat sinks of sufficient capacity to prevent excessive draw down of the tool

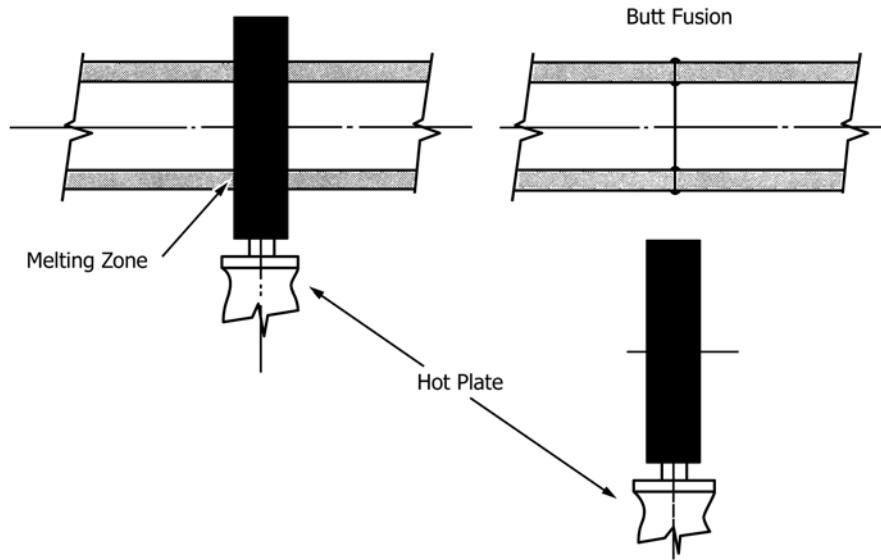

FIG. 2 Typical Butt Fusion Operation

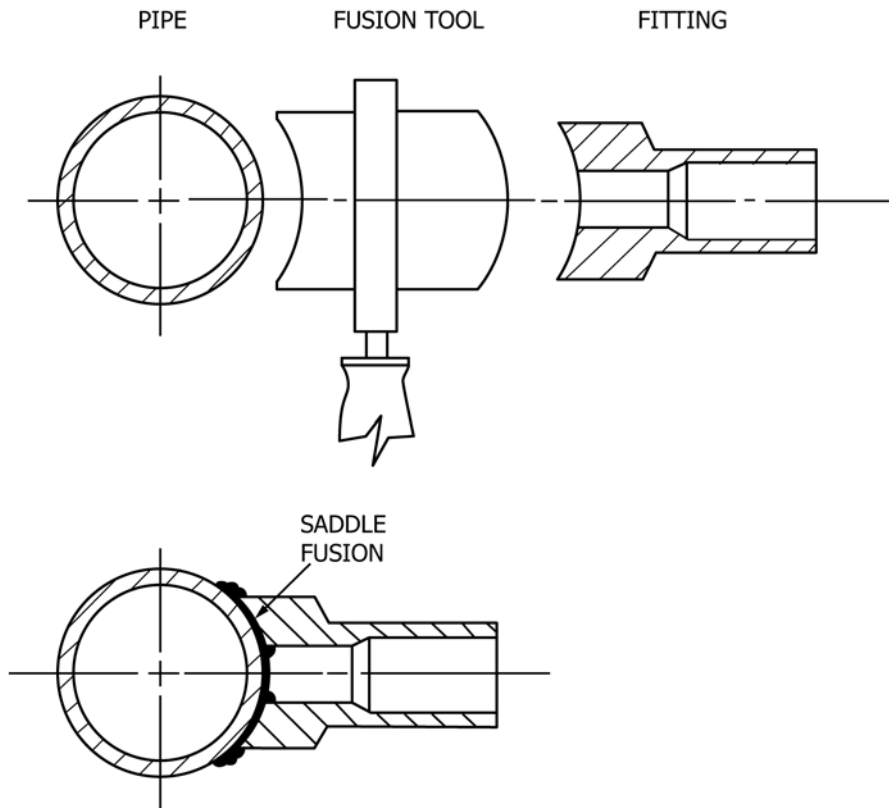

FIG. 3 Saddle Fusion

temperature, and are used only in above-freezing conditions. Electric heating plates maintain consistent fusion temperatures when provided with an adequate power source. Electric heating plates for general fusion use shall be controlled thermostatically and most are adjustable for a set point temperature ranging from 300 to 575°F (150 to 300°C). Some tools may have a fixed set point for a particular application.

6.2 *Heating Tool Faces*—Heating tools may be made from materials such as aluminum, stainless steel, copper, or copper

alloys. Copper or copper-alloy heating faces are not suitable, unless chromium-plated or clad with another suitable metal, because some polyolefins react with copper. Plastic materials may stick to hot metal heating surfaces. This sticking may be minimized by applying a non-stick coating to the heating surfaces or by fitting a high-temperature, non-stick fabric over the heating surfaces. The heating plate surfaces, coated or uncoated, shall be kept clean and free of contaminants such as dirt, grease and plastic build-up, which may cause excessive

sticking and create unsatisfactory joints. Most of these contaminants are removed from the hot tool surfaces using a clean, dry, oil-free lint-free cloth. Do not use synthetic fabrics which may char and stick to the fusion surface. Some pigments, such as carbon black, may stain a heating surface and probably cannot be removed; such stains will not contaminate the joint interface.

6.2.1 After a period of time in service, non-stick coatings or fabrics will deteriorate and become less effective. Deteriorated fabrics should be replaced, and worn, scratched, or gouged non-stick coatings should be re-coated when they lose effectiveness. Heat fusion quality may be adversely affected by deteriorated non-stick surfaces. Spray-on chemicals, such as non-stick lubricants or oils shall not be applied to heating iron surfaces as they will contaminate the joint.

6.3 *Temperature Indicator*—Heating tools shall be equipped with a thermometer or other built-in temperature indicating device. This device indicates the internal temperature of the heating iron which is usually higher than temperature of the fusion surfaces. Use a pyrometer periodically to verify the temperature of the tool surfaces within the pipe or fitting contact area. Select multiple checkpoints to ensure uniform surface temperature.

NOTE 2—A significant temperature variation, that is, cold spots, on the fusion surfaces may indicate a faulty heating iron which may need to be serviced before it can be used.

7. Procedure 1—Socket Fusion

7.1 *Apparatus*—Socket fusion tools manufactured in accordance with Specification **F1056** are used for joining polyolefin pipe, tubing, and fittings.

7.1.1 *Heating Tool*—In order to obtain a proper melt, it is necessary for a uniform temperature to be maintained across the heating surface. Therefore, gas-fired tools are generally restricted to use with pipe sizes of 2 in. IPS (63 mm) or less.

7.1.2 *Heating Tool Faces*—Consisting of two parts, a male end for the interior socket surface and a female end for the exterior pipe surface. Both parts shall be made to such tolerances as to cause an interference fit.

7.1.3 *Alignment Jig*—The alignment jig is an optional tool which consists of two sets of devices holding the components in alignment to each other. One set of holding devices is fixed, and the other allows longitudinal movement for making the joint.

7.1.4 *Rounding Clamps*, (cold ring) to maintain roundness of the pipe and control the depth of pipe insertion into the socket during the joining operation.

7.1.5 *Depth Gage*, for proper positioning of the rounding clamp.

7.1.6 *Chamfering Tool*, to bevel the end of the pipe.

NOTE 3—The depth gage and chamfering tool may be combined into a single tool.

7.1.7 *Tubing Cutter*, to obtain a square end cut on the pipe.

7.1.8 *Fitting Puller*, an optional tool to assist in the removal of the fitting from the heating tool and to hold the fitting during assembly.

7.2 *Procedure*:

7.2.1 Attach the proper size heater faces to the heating tool, and heat the tool to the fusion temperature for the material.

7.2.2 Cut the pipe end squarely, and clean the pipe end and fitting, both inside and outside, by wiping with a clean, dry, oil-free, lint-free cloth.

7.2.3 Chamfer the outside edge of the pipe end slightly and fix the rounding clamp about the pipe as determined from the depth gage.

NOTE 4—Chamfering may not be required by some procedures or some fusion tools. Pipe sizes 1 in. (25.4 mm) and smaller are not usually chamfered, regardless of tooling design.

NOTE 5—Some recommend using a 50 to 60-grit emery or garnet cloth to roughen the outside of the pipe and inside of the fitting as a means of minimizing any possible skin interface when making the fusion. Sandpaper is not recommended for this purpose, as it might disintegrate and contaminate the joint interface. If roughening is performed, first clean the surfaces before roughening. Clean dust and particles from the roughened surfaces afterwards by wiping with a clean, dry, oil-free, lint-free cloth.

7.2.4 Bring the preheated tool faces into contact with the outside surface of the end of the pipe and the inside surface of the socket.

7.2.5 Heat the pipe end and the fitting socket for the time required to obtain a proper melt. Proper melt is a function of material, time, tool temperature, and the size of the parts. Pipe and fittings of larger diameters require more time to reach the proper melt consistency than those of smaller diameters. Underheated or overheated materials will not form a good bond.

7.2.6 At the end of the heating time, simultaneously remove the pipe and fitting straight out from the tool, using a snap action. Immediately insert the pipe straight into the socket of the fitting so the rounding clamp is flush against the end of the fitting socket. Hold or block the joint in place until the melts of the mating surfaces have solidified. The exact cooling time depends on the size of the pipe and the material being fused.

7.2.7 Remove the rounding clamp, and inspect the melt pattern at the end of the socket for a complete impression of the rounding clamp in the melt surface. There shall no gaps, voids, or unbonded areas. Clean the heating tool of any residual material using a wood stick or a clean, dry, oil-free, lint-free, non-synthetic cloth. Take care not to damage the heating surfaces. Plastic left on the tool tends to char when reheated, causing a loss of heater efficiency and joint contamination.

7.2.8 Allow for extremes in weather when making field joints. Heating times, operation of alignment jig, dimensional changes, and the like, are affected by extreme conditions.

7.3 *Testing*—Evaluate sample joints in order to verify the skill and knowledge of the fusion operator. Cut joints into straps, (see Fig. 4) and visually examine and test for bond continuity and strength. Bending, peeling, and elongation tests are useful for this purpose.

8. Procedure 2—Butt Fusion

8.1 *Apparatus*:

8.1.1 *Heating Tool*—The heating tool shall have sufficient area to adequately cover the ends of the size of pipe to be joined.

8.1.2 *Alignment Jig*—The alignment jig is three basic parts: (1) a stationary clamping fixture and a movable clamping

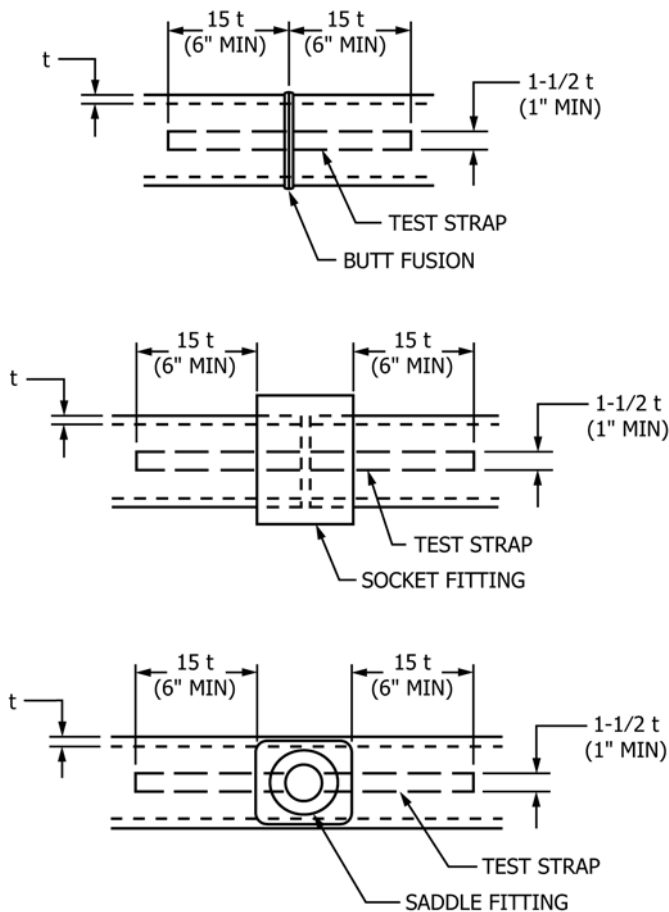

FIG. 4 Bent Strap Test Specimen

fixture for holding each of the two parts to be fused in alignment; (2) a facer for simultaneously preparing the ends of the parts to be joined (Note 6); and (3) appropriate adapters for different pipe sizes. Alignment jigs are manually or hydraulically powered.

NOTE 6—A facer is a rotating cutting device used to square-off the pipe or fitting ends to obtain properly mating fusion surfaces.

8.2 Procedure:

8.2.1 Bring the heater plate surfaces to proper temperature.

8.2.2 Clean the inside and outside of the components (pipe or pipe and fitting) to be joined. Remove all foreign matter from the surface of the component where it will be clamped in the alignment jig.

8.2.3 Align each component with its alignment jig clamp, and close the clamp. Check component to component alignment, adjust as needed, and face off the ends.

8.2.3.1 Take care when placing pipe or fittings in the alignment jig. Pipes shall be aligned before the alignment clamp is closed; however, do not force the pipe into alignment by pushing it against the side of an open alignment jig clamp.

8.2.4 Bring the piping components together and check for high-low alignment, and out-of-roundness. Adjust as required. Re-face after adjustment. The ends of the piping components shall be square to each other around their full circumference.

8.2.5 Place the heater plate between the component ends, and move the component ends against the heater plate with sufficient force to ensure complete circumferential contact against the heater plate. Hold the components against the heater plate briefly, using limited force to ensure that proper contact with the plate has been made. Release the force, but hold the components against the heater plate until an appropriately sized bead of molten plastic develops circumferentially around each component end as a result of the thermal expansion of the material. Do not push the components into the heater plate as the melting progresses.

8.2.6 Move the melted component ends away from the heater plate, and remove the heater plate. Quickly inspect the melted surfaces per 8.2.1. If the melt is acceptable, immediately bring the melted ends together with enough force to roll both component melt beads over to the pipe surface around the entire circumference of the joint. When the bead touches the pipe surface, stop moving the component ends together, but do not release the force. Hold the force on the joint until the joint has cooled.

8.2.6.1 Do not use excessive or insufficient force. If the components are brought together with too much force, all molten material may be pushed out of the joint and cold material brought into contact forming a “cold” joint. If too little force is used, only the melt in the beads may be fused together and, as the molten material in the joint cools and contracts, voids or non-fused areas may be formed. If the softened material sticks to the heater plate, discontinue the joining procedure. Clean the heater plate, re-square the component ends, and repeat the process from the beginning (8.2.2).

8.2.6.2 Inspect the component ends quickly when the heating tool is removed. The melt should be flat. A concave melt surface indicates unacceptable pressure during heating. If a concave melt surface is observed, do not continue. Allow the component ends to cool, and start over from 8.2.1.

8.2.6.3 For any pipe size and wall thickness, the actual fusion joining force is determined by multiplying the interfacial pressure by the area of the pipe end. To determine a fusion pressure gauge setting for hydraulic butt fusion machines, the force is divided by the area of the hydraulic cylinders that move the fusion machine carriage. The hydraulic fusion machine gauge pressure setting may need to be increased to overcome internal machine friction drag or to provide additional force to move pipes attached to the butt fusion machine.

8.2.7 Allow the assembly to stand at least until cool before removing the clamps or other aligning device (Note 7). Do not subject the joint to high stress until it has cooled to less than approximately 130°F. Do not apply internal pressure until the joint and surrounding material have reached ambient air temperature.

NOTE 7—The joint is usually cool enough to remove from the alignment jig if a bare hand can be held against the beads without discomfort (less than approximately 130°F). Further cooling is recommended prior to ditching the pipe.

8.2.8 Visually inspect the joint against recommended appearance guidelines. The beads should be uniformly shaped and sized all around the joint.

8.3 *Testing*—Evaluate sample joints to verify the skill and knowledge of the fusion operator. In some cases, butt-fusion joints can be nondestructively examined using ultrasonic equipment to detect voids or other discontinuities. Visually, the width of butt fusion beads should be 2 to 2-½ times the bead height above the pipe, and the beads should be rounded and uniformly sized all around the pipe circumference. The v-groove between the beads should not be deeper than half the bead height above the pipe surface. When butt fusing to molded fittings, the fitting-side bead may display shape irregularities such as minor indentations, deflections and non-uniform bead rollover from molded part cooling and knit lines. In such cases, visual evaluation is based mainly on the size and shape of the pipe-side bead. For destructive tests, cut joints into straps (see Fig. 4), visually examine, and test for bond continuity and strength. Tests that have been found useful for this purpose include inside face bend, outside face bend, tensile elongation, torque, and impact. Quantifiable data may be obtained by the use of laboratory procedures and comparing data against that from control samples.

9. Procedure 3—Saddle Fusion

9.1 Apparatus:

9.1.1 *Heating Tool Faces*—The faces are matched sets, by pipe size, of concave and convex blocks which bolt or clamp onto a flat or round core heater.

9.1.2 *Alignment Jigs*—Various types of alignment jigs are available. Alignment jigs provide a means to mount the alignment jig on the pipe, hold the fitting and align it to the pipe, and move the fitting towards and away from the pipe. Alignment jigs are used for saddle fusions for optimum results and are required for certain materials.

NOTE 8—Some materials may be saddle fused using a hand-stab procedure. Consult the manufacturer for a hand-stab procedure.

9.2 Procedure:

9.2.1 Bring heater plate and faces to proper temperature.

9.2.2 Clean the mating surfaces of the pipe and the concave surface of the fitting base and roughen the mating surfaces. Emery or garnet cloth of 50 to 60 grit is used to remove the

tough outer surface skin. It is essential to remove the surface skin completely without altering the contours of the mating surfaces and to keep the surface clean. Remove dust and particles from the surface after roughing with a clean, dry, oil-free, lint-free cloth.

9.2.3 Install the alignment jig on the pipe. For smaller pipe sizes, install a bolster plate under the pipe to provide additional support.

9.2.4 Install the fitting in the alignment jig. Press the fitting against the pipe to align the fitting base to the pipe, then secure the fitting in the alignment jig.

9.2.5 Place the heater on the pipe and press the fitting against the heater to obtain a melt on both the pipe and the fitting.

NOTE 9—When saddle fittings are fused to pipes that are under pressure, it is important that the surface melt be obtained quickly without too much heat penetration. Otherwise, the pipe may rupture from internal pressure. Consult the manufacturer for specific recommendations for fusing saddle fittings to pipe under pressure.

9.2.6 When a proper melt is achieved, remove the heater, quickly examine the pipe and fitting to ensure proper melt patterns, and immediately place the fitting on the pipe. Hold in place while exerting suitable force for the specified cooling time.

NOTE 10—If a suitable melt pattern has not been achieved, do not reheat; however, continue with the fusion and apply the fitting to the pipe. When the joint has cooled, remove the alignment jig, cut off the top of the fitting to prevent use, and start over at another location.

9.3 Visually inspect the joint against recommended visual inspection guidelines.

9.4 *Testing*—Evaluate sample joints to verify the skill and knowledge of the fusion operator. Cut joints into straps (see Fig. 4), visually examine, and test for bond continuity and strength.

10. Keywords

10.1 butt fusion; fitting; heat fusion; joining; pipe; polybutylene; polyolefin; polypropylene; saddle fusion; socket fusion

ANNEX

(Mandatory Information)

A1. COLD WEATHER PROCEDURES

A1.1 *Cold Weather Handling*—Pipe should be inspected for damage. Polyolefin pipes have reduced impact resistance in sub-freezing conditions. Avoid dropping pipe in sub-freezing conditions. When handling coiled pipe at temperatures below 40°F, it is helpful to uncoil the pipe prior to installation and let it straighten out. Gradually uncoil the pipe and cover it with dirt at intervals to keep it from recoiling. Always use caution when cutting the straps on coils of pipe because the outside end of a coil may spring out when the strapping is removed.

A1.2 *Preparation for Socket, Saddle, and Butt Fusion Joining:*

A1.2.1 *Wind and Precipitation*—The heating tool should be shielded in an insulated container to prevent excessive heat loss. Shield the pipe fusion area and fusion tools from wind, snow, and rain by using a canopy or similar device.

A1.2.2 Pipe and Fitting Surface Preparation—The pipe and fitting surfaces to be “joined” or held in clamps should be dry and clean and free of ice, frost, snow, dirt, and other contamination. Regular procedures for preparation of surfaces to be joined, such as facing for butt fusion and roughening for saddle fusion should be emphasized. After preparation, the surfaces should be protected from contamination until joined. Contamination of the area to be fused will likely cause incomplete fusion. Frost and ice on the surfaces of the pipe to be clamped in either a cold ring or alignment jigs may cause slippage during fusion. Inspect coiled pipe to see if it has flattened during storage which could cause incomplete melt pattern or poor fusion. It may be necessary to remove several inches at the pipe ends to eliminate such distortion. Pipe may have a slight toe-in or reduced diameter for several inches at the end of the pipe. The toe-in may need to be removed before butt fusing to a freshly cut pipe end, or to a fitting.

A1.2.3 Heating—Work quickly once pipe and fitting have been separated from the heating tool, so that melt heat loss is minimized, but still take time (no more than 3 s) to inspect both melt patterns. Keep the heater dry at all times. Check the temperature of the heating tool regularly with a pyrometer. Keep the heating tool in an insulated container between fusions. Do not increase heating tool temperature above the specified temperature setting. Gas-fired heating tools are used only in above freezing conditions.

A1.3 Socket Fusion:

A1.3.1 Pipe Outside Diameter—Pipe outside diameter contracts when cold. This results in loose or slipping cold rings. For best results, clamp one cold ring in its normal position adjacent to the depth gage. Place shim material (that is, piece of paper or rag, etc.) around the inside diameter of a second rounding ring and clamp this cold ring directly behind the first cold ring to prevent slippage. The first cold ring allows the pipe adjacent to the heated pipe to expand to its normal diameter during the heating cycle.

A1.3.2 Fitting Condition—If possible, store socket fittings at a warm temperature, such as in a truck cab, prior to use. This will make it easier to place the fitting on the heating tool because fittings contract when cold.

A1.3.3 Heating—At colder temperatures the pipe and fitting contract, thus the pipe slips more easily into the heating tool. At very cold outdoor temperatures (particularly with 2, 3, and 4 in. IPS pipe), the pipe may barely contact the heating surface.

Longer heating cycles are used so that the pipe first expands (from tool heat) to properly contact the heating tool, then develops complete melt. The length of cycle necessary to obtain a complete melt pattern will depend not only on the outdoor (pipe) temperature but wind conditions and operator variation. Avoid cycles in excess of that required to achieve a good melt pattern. To determine the proper cycle time for any particular condition, make a melt pattern on a scrap piece of pipe, using the heating cycle as instructed by the pipe manufacturer. If the pattern is incomplete (be sure rounding rings are being used), try a 3-s longer cycle on a fresh (cold) end of pipe. If the melt pattern is still not completely around the pipe end, add an additional 3 s and repeat the procedure. Completeness of melt pattern is the key. Keep the heater dry at all times. Check the temperature of the heating tool regularly and keep the heating tool in an insulated container between fusions.

A1.4 Butt Fusion:

A1.4.1 Joining—It will take longer to develop the initial melt bead completely around the pipe ends. Do not increase pressure during heating. When proper melt bead has been obtained, the pipe and heater shall be separated in a rapid, snap-like motion. The melted surfaces shall then be joined immediately in one smooth motion so as to minimize cooling of the melted pipe ends.

A1.5 Saddle Fusion:

A1.5.1 Surface Preparations—Regular procedures for roughening the surfaces to be fused on the pipe and the fitting should be emphasized. After the surfaces have been prepared, particular care should be taken to protect against contamination.

A1.5.2 Heating Time—Make a trial melt pattern on a scrap piece of pipe. A clean, dry piece of wood is used to push the heating tool against the pipe. If the melt pattern is incomplete, add 3 s to the cycle time and make another trial melt pattern on another section of cold pipe. If the pattern is still incomplete, continue 3-s additions on a fresh section of cold pipe until a complete melt pattern is attained. Use this heating cycle for fusions during prevailing conditions. Regardless of the weather or the type of tools used, the important point to remember is that complete and even melt must occur on the fitting and the pipe in order to produce a good fusion joint. This requires pipe preparation to make it clean, straight, round, and well supported.

ASTM International takes no position respecting the validity of any patent rights asserted in connection with any item mentioned in this standard. Users of this standard are expressly advised that determination of the validity of any such patent rights, and the risk of infringement of such rights, are entirely their own responsibility.

This standard is subject to revision at any time by the responsible technical committee and must be reviewed every five years and if not revised, either reapproved or withdrawn. Your comments are invited either for revision of this standard or for additional standards and should be addressed to ASTM International Headquarters. Your comments will receive careful consideration at a meeting of the responsible technical committee, which you may attend. If you feel that your comments have not received a fair hearing you should make your views known to the ASTM Committee on Standards, at the address shown below.

This standard is copyrighted by ASTM International, 100 Barr Harbor Drive, PO Box C700, West Conshohocken, PA 19428-2959, United States. Individual reprints (single or multiple copies) of this standard may be obtained by contacting ASTM at the above address or at 610-832-9585 (phone), 610-832-9555 (fax), or service@astm.org (e-mail); or through the ASTM website (www.astm.org). Permission rights to photocopy the standard may also be secured from the Copyright Clearance Center, 222 Rosewood Drive, Danvers, MA 01923, Tel: (978) 646-2600; http://www.copyright.com/