



Designation: D2534 – 88 (Reapproved 2017)

Standard Test Method for Coefficient of Kinetic Friction for Wax Coatings¹

This standard is issued under the fixed designation D2534; the number immediately following the designation indicates the year of original adoption or, in the case of revision, the year of last revision. A number in parentheses indicates the year of last reapproval. A superscript epsilon (ϵ) indicates an editorial change since the last revision or reapproval.

1. Scope

1.1 This test method covers the determination of the coefficient of kinetic friction for a petroleum wax coating or wax-based hot melt coating when sliding over itself.

1.2 *This standard does not purport to address all of the safety concerns, if any, associated with its use. It is the responsibility of the user of this standard to establish appropriate safety and health practices and determine the applicability of regulatory limitations prior to use.*

1.3 *This international standard was developed in accordance with internationally recognized principles on standardization established in the Decision on Principles for the Development of International Standards, Guides and Recommendations issued by the World Trade Organization Technical Barriers to Trade (TBT) Committee.*

2. Referenced Documents

2.1 *ASTM Standards:*²

[D585 Practice for Sampling and Accepting a Single Lot of Paper, Paperboard, Fiberboard, and Related Product \(Withdrawn 2010\)](#)³

[D1465 Test Method for Blocking and Picking Points of Petroleum Wax](#)

3. Terminology

3.1 *Definitions:*

3.1.1 *friction, n*—the resistance to sliding exhibited by two surfaces in contact with each other. Basically there are two frictional properties exhibited by any surface; static friction and kinetic friction.

3.1.2 *kinetic friction, n*—the force that resists motion when a surface is moving with a uniform velocity; it is, therefore,

¹ This test method is under the jurisdiction of ASTM Committee D02 on Petroleum Products, Liquid Fuels, and Lubricants and is the direct responsibility of Subcommittee D02.10.0A on Physical/Chemical Properties.

Current edition approved June 1, 2017. Published July 2017. Originally approved in 1966. Last previous edition approved in 2012 as D2534 – 88 (2012). DOI: 10.1520/D2534-88R17.

² For referenced ASTM standards, visit the ASTM website, www.astm.org, or contact ASTM Customer Service at service@astm.org. For *Annual Book of ASTM Standards* volume information, refer to the standard's Document Summary page on the ASTM website.

³ The last approved version of this historical standard is referenced on www.astm.org.

equal and opposite to the force required to maintain sliding of the surface with a uniform velocity.

4. Summary of Test Method

4.1 A coated surface under load is pulled at a uniform rate over a second coated surface. The force required to move the load is measured, and the coefficient of kinetic friction is calculated.

5. Significance and Use

5.1 The coefficient of friction is related to the slip properties of many commercial articles that have been coated with petroleum wax (for example, butter cartons and wax-impregnated or hot melt coated corrugated board).

6. Apparatus

6.1 *Sled Assembly*, as shown in Fig. 1, weighing 180 g \pm 1 g, and consisting of the following parts:

6.1.1 *Brass Block*, 25 mm (1 in.) wide by 13 mm (1/2 in.) thick by 75 mm (3 in.) long,

6.1.2 *Microscope Slide*, cemented to one surface, 25 mm (1 in.) by 75 mm (3 in.), and

6.1.3 *Detachable Handle*, using 1.5 mm (1/16 in.) weld rod.

6.2 *Horizontal Plane Assembly and Pulling Device*, consisting of a metal or wood sheet covered by a smooth, flat piece of glass approximately 150 mm by 300 mm (6 in. by 12 in.). The plane shall be supported by two 250 mm by 300 mm (10 in. by 12 in.) diagonal shelf-brackets. A board attached across the brackets shall be clamped in the jaws of the lower crosshead of an electronic load cell-type tension tester. Adjust the assembly so that the glass surface is level. Attach a low-friction pulley at the edge of the plane with the outer side centered directly beneath the load cell of the testing machine and the bottom side level with the sled handle. Connect the sled handle to the load cell of the tester by a light, flexible metal cable or polyester cord passing around the pulley.

6.3 *Low-Friction Pulley*, consisting of a pulley mounted in hardened steel cone bearings on a metal fork. The pulley should be constructed from materials having hardness and durability equivalent to phenolic-type materials.

7. Materials

7.1 *Scissors or Cutter*, suitable for cutting waxed specimen to the desired dimensions.

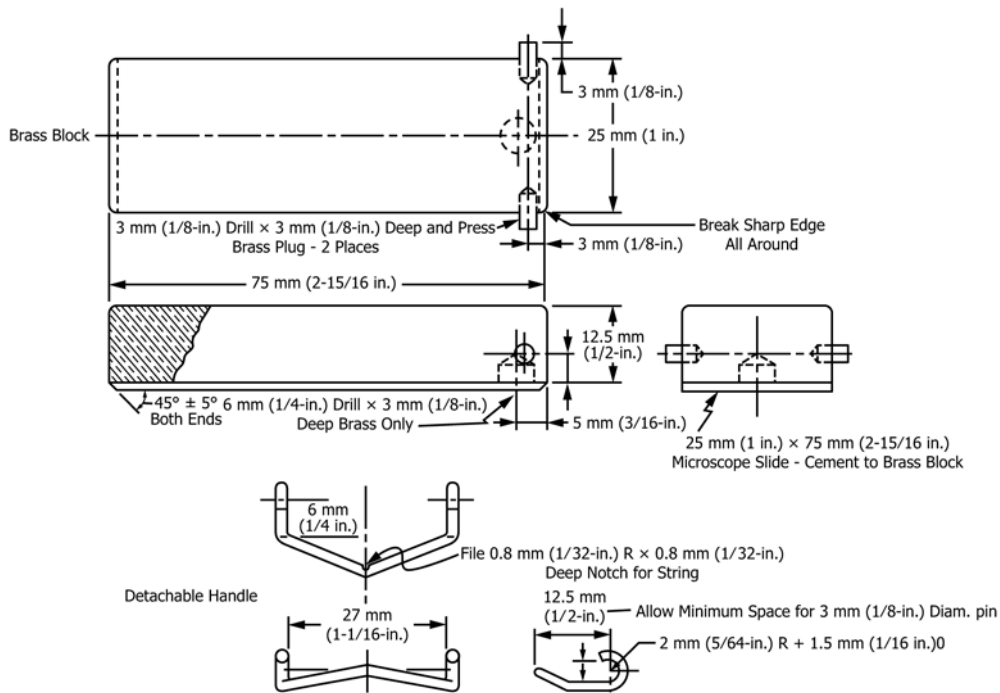

FIG. 1 Coefficient of Kinetic Friction Sled Assembly

7.2 *Adhesive Tapes*, single-faced and double-faced, 13 mm to 20 mm (1/2 in. to 3/4 in.) in width.

8. Sampling and Test Specimens

8.1 Test specimens may be flexible, such as wax-coated paper, or rigid, such as wax-coated paperboard or corrugated (Note 1). From each test unit obtained in accordance with Practice D585:

8.1.1 For wax-coated paper, cut test specimens of two sizes: 250 mm by 130 mm (10 in. by 5 in.) and 120 mm by 25 mm (5 in. by 1 in.).

8.1.2 For wax-coated paperboard or corrugated board, cut test specimens of two sizes: 250 mm by 130 mm (10 in. by 5 in.) and 75 mm by 25 mm (3 in. by 1 in.).

NOTE 1—For evaluation of wax, it is necessary to prepare test specimens. Test Method D1465 describes the apparatus used for applying wax to paper, and a method for testing to determine that the correct wax or wax blend has been applied.

8.2 The smaller specimen shall be mounted on the sled assembly. If, during the test, this mounted specimen presents a sharp leading edge, it may dig or plow into the surface of the second specimen. To avoid this, bevel the leading edge (25 mm direction) of the specimen to match the bevel on the glass slide (see Fig. 1).

8.3 Test three pairs of specimens from each sample of wax and use a fresh pair of surfaces for each test.

9. Conditioning

9.1 Condition the specimens and conduct the test at 23 °C ± 2 °C (73 °F ± 3.5 °F) and 50 % ± 5 % relative humidity.

10. Procedure

10.1 Lay down two strips of double-faced adhesive tape along the length of the plane so that they are approximately 100 mm (4 in.) between centers.

10.2 Attach the 250 mm by 130 mm specimen to the double-faced tape on the horizontal plane.

NOTE 2—For wax-coated paper, make the attachment so that the specimen is free of wrinkles.

10.2.1 For wax-coated paper, tape the ends of the 120 mm by 25 mm (5 in. by 1 in.) specimen to the top of the sled, pulling the specimen tightly across the sliding surface to eliminate wrinkles.

10.2.2 For wax-coated paperboard or corrugated board, place a strip of double-faced tape on the bottom face of the sled. Place the 75 mm by 25 mm (3 in. by 1 in.) specimen against the tape, square with the sled and with the bevel-cut edge at the handle end. The bevel cut on the leading edge reduces the possibility of the sled specimen plowing into the base specimen.

10.3 Set the sled lightly in position at the rear end of the 250 mm by 130 mm (10 in. by 5 in.) specimen and in line with the pulley. Attach the sled by means of the handle to the cord. This pulling cord passes from the sled handle, underneath and around the pulley vertically to the load cell.

10.4 Start the lower crosshead horizontal plane assembly moving downward at a speed of 900 mm/min (35 in./min).

10.5 Record in grams the average reading during the 152 mm (6 in.) of travel after the first 13 mm (0.5 in.). After the sled has traveled 178 mm (7 in.), stop the apparatus. Return the crosshead to the starting position.

11. Calculations

11.1 Calculate the coefficient of kinetic friction, μ_k , as follows:

$$\mu_k = A/B \quad (1)$$

where:

- A = average scale reading for 150 mm (6 in.) of uniform sliding, and
 B = sled weight, g.

12. Report

12.1 Report the average of three separate tests as the coefficient of kinetic friction (μ_k) to two significant figures.

13. Precision and Bias

13.1 The precision of this test method as determined by statistical examination of interlaboratory results is as follows:

13.1.1 *Repeatability*—The difference between two test results, obtained by the same operator with the same apparatus under constant operating conditions on identical test material,

would in the long run, in the normal and correct operation of the test method, exceed the following values only in one case in twenty:

$$0.06 (\mu_k \text{ in range from 0 to 1}) \quad (2)$$

13.1.2 *Reproducibility*—The difference between two single and independent results obtained by different operators working in different laboratories on identical test material would, in the long run, in the normal and correct operation of the test method, exceed the following values only in one case in twenty:

$$0.17 (\mu_k \text{ in range from 0 to 1}) \quad (3)$$

13.2 The above precision data were obtained in a round-robin involving nine laboratories on four samples.

13.3 *Bias*—The procedure in this test method has no bias because the value of coefficient of kinetic friction can be defined only in terms of a test method.

14. Keywords

14.1 coefficient of kinetic friction; kinetic friction; wax; wax coatings

ASTM International takes no position respecting the validity of any patent rights asserted in connection with any item mentioned in this standard. Users of this standard are expressly advised that determination of the validity of any such patent rights, and the risk of infringement of such rights, are entirely their own responsibility.

This standard is subject to revision at any time by the responsible technical committee and must be reviewed every five years and if not revised, either reapproved or withdrawn. Your comments are invited either for revision of this standard or for additional standards and should be addressed to ASTM International Headquarters. Your comments will receive careful consideration at a meeting of the responsible technical committee, which you may attend. If you feel that your comments have not received a fair hearing you should make your views known to the ASTM Committee on Standards, at the address shown below.

This standard is copyrighted by ASTM International, 100 Barr Harbor Drive, PO Box C700, West Conshohocken, PA 19428-2959, United States. Individual reprints (single or multiple copies) of this standard may be obtained by contacting ASTM at the above address or at 610-832-9585 (phone), 610-832-9555 (fax), or service@astm.org (e-mail); or through the ASTM website (www.astm.org). Permission rights to photocopy the standard may also be secured from the Copyright Clearance Center, 222 Rosewood Drive, Danvers, MA 01923, Tel: (978) 646-2600; http://www.copyright.com/