



Designation: D2509 – 14<sup>ε1</sup>

## Standard Test Method for Measurement of Load-Carrying Capacity of Lubricating Grease (Timken Method)<sup>1</sup>

This standard is issued under the fixed designation D2509; the number immediately following the designation indicates the year of original adoption or, in the case of revision, the year of last revision. A number in parentheses indicates the year of last reapproval. A superscript epsilon ( $\epsilon$ ) indicates an editorial change since the last revision or reapproval.

<sup>ε1</sup> NOTE—The IP designation was removed and footnote 1 was revised editorially in March 2017.

### 1. Scope\*

1.1 This test method covers the determination of the load-carrying capacity of lubricating greases by means of the Timken Extreme Pressure Tester.

1.2 The values stated in SI units are to be regarded as the standard. The values given in parentheses are for information only.

1.3 *This standard does not purport to address all of the safety concerns, if any, associated with its use. It is the responsibility of the user of this standard to establish appropriate safety and health practices and determine the applicability of regulatory limitations prior to use.* For specific warning statements, see 7.1, 7.2, and 9.4.

### 2. Referenced Documents

#### 2.1 ASTM Adjuncts:

Glossy Prints of Test Blocks Showing Various Types of Scar<sup>2</sup>

### 3. Terminology

#### 3.1 Definitions:

3.1.1 *load-carrying capacity, of a lubricating grease, n*—the maximum load or pressure that can be sustained by a lubricating grease without failure of the sliding contact surfaces as evidenced by seizure or welding.

3.1.1.1 *Discussion*—The values of load carrying capacity of a lubricating grease vary according to test method.

3.1.2 *scoring, in tribology, n*—a severe form of wear characterized by the formation of extensive grooves and scratches in the direction of sliding.

<sup>1</sup> This test method is under the jurisdiction of ASTM Committee D02 on Petroleum Products, Liquid Fuels, and Lubricants and is the direct responsibility of Subcommittee D02.G0.04 on Functional Tests - Tribology.

Current edition approved Oct. 1, 2014. Published February 2015. Originally approved in 1966. Last previous edition approved in 2008 as D2509 – 03 (2008). DOI:10.1520/D2509-14E01.

<sup>2</sup> Available from ASTM International Headquarters. Order Adjunct No. ADJD2509. Original adjunct produced in 1972.

3.1.2.1 *Discussion*—When the lubricant film is substantially maintained, a smooth scar is obtained on the test block, but when there is a breakdown of the lubricant film, scoring or surface failure of the test block takes place as shown in Fig. 1.<sup>2</sup> In its simplest and recognized form, scoring is characterized by a wide scar on the test block and by the transfer of metal from the test block to the contacting surface of the test cup. The form of surface failure more usually encountered, however, consists of a comparatively smooth scar, which shows local damage that usually extends beyond the width of the scar. Scratches or striations that occur in an otherwise smooth scar and that do not extend beyond the width of the scar are not considered scoring in this test method. The term scuffing is sometimes used as a synonym for scoring.

3.1.3 *seizure or welding, n*—localized fusion of rubbing metal, usually indicated by streaks of transferred metal, increased friction and wear, or unusual noise and vibration.

3.1.4 *wear, n*—the removal of metal from a rubbing surface by mechanical action, or by a combination of mechanical and chemical actions.

#### 3.2 Definitions of Terms Specific to This Standard:

3.2.1 *OK value, n*—the maximum mass (weight) added to the load lever mass (weight) pan, at which no scoring or seizure occurs.

3.2.2 *score value, n*—the minimum mass (weight) added to the load lever mass (weight) pan, at which scoring or seizure occurs.

### 4. Summary of Test Method

4.1 The tester is operated with a steel test cup rotating against a steel test block. The rotational speed is  $800 \pm 5$  r/min, which is equivalent to a linear speed of  $123.71 \pm 0.77$  m/min ( $405.88 \pm 2.54$  ft/min). Grease samples are brought to and applied at  $24 \pm 6^\circ\text{C}$  ( $75 \pm 10^\circ\text{F}$ ).

4.2 Two determinations are made: the minimum load (score value) that will rupture the lubricant film being tested between the rotating cup and the stationary block and cause adhesion; and the maximum load (OK value) at which the rotating cup will not rupture the lubricant film and cause adhesion between the rotating cup and the stationary block.

\*A Summary of Changes section appears at the end of this standard

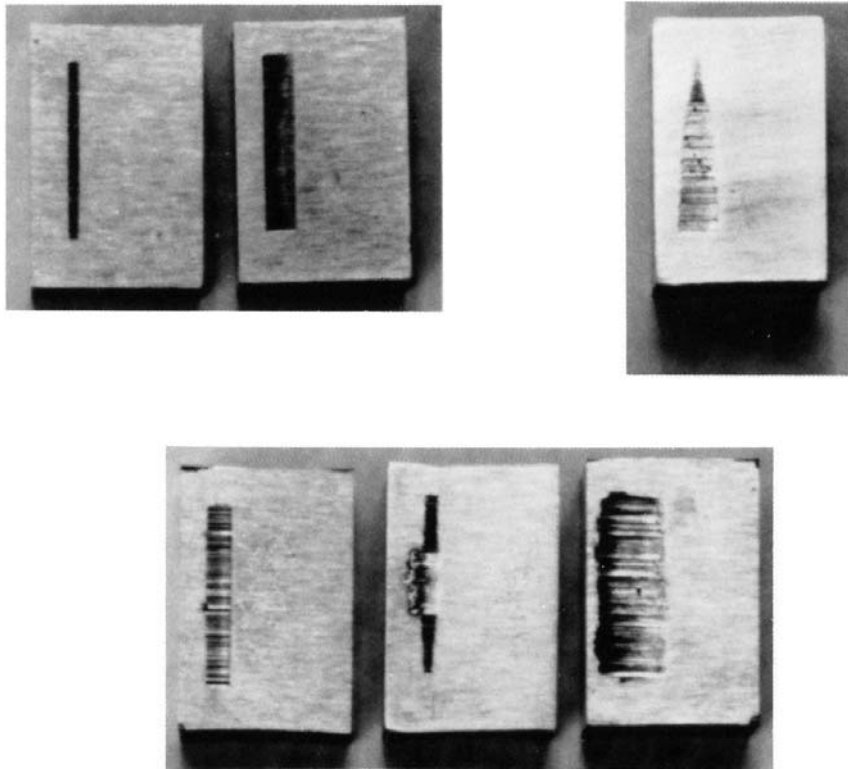

**FIG. 1 Test Blocks Showing Various Types of Scar**

## 5. Significance and Use

5.1 The test method is used widely for specification purposes and is used to differentiate between greases having low, medium, or high levels of extreme pressure characteristics. The results may not correlate with results from service.

## 6. Apparatus and Materials

6.1 *Timken Extreme Pressure Tester*, described in detail in [Annex A1](#) and illustrated in [Fig. 2](#).

6.2 *Sample Feed Devices*, for supplying the test specimens with grease are described in [Annex A1](#).

6.3 *Loading Mechanism*, for applying and removing the load mass (weight) without shock at the uniform rate 0.91 to 1.36 kg/s (2 to 3 lb/s). A detailed description is given in [Annex A1](#).

6.4 *Test Cups*,<sup>3,4</sup> of carburized steel, having a Rockwell Hardness C Scale Number of 58 to 62, or a Vickers Hardness Number of 653 to 746. The cups have a width of  $13.06 \pm 0.05$  mm ( $0.514 \pm 0.002$  in.), a perimeter of  $154.51 \pm 0.23$  mm ( $6.083 \pm 0.009$  in.), a diameter of  $49.22 +0.025, -0.127$  mm ( $1.938 +0.001, -0.005$  in.), and a maximum radial run-out of 0.013 mm (0.0005 in.). The axial surface roughness should lie between 0.51 and 0.76  $\mu$ m (20 and 30  $\mu$ in.) C.L.A.

<sup>3</sup> The sole source of supply of the test cups known to the committee at this time is Falex Corporation, 1020 Airpark Dr., Sugar Grove, IL, 60554-9585 under Part No. F-25061.

<sup>4</sup> If you are aware of alternative suppliers, please provide this information to ASTM International Headquarters. Your comments will receive careful consideration at a meeting of the responsible technical committee,<sup>1</sup> which you may attend.

6.5 *Test Blocks*<sup>4,5</sup> with test surfaces  $12.32 \pm 0.10$  mm ( $0.485 \pm 0.004$  in.) wide and  $19.05 \pm 0.41$  mm ( $0.750 \pm 0.016$  in.) long, of carburized steel, having a Rockwell Hardness C Scale Number of 58 to 62, or a Vickers Hardness Number of 653 to 746. Each block is supplied with four ground faces and the surface roughness should lie between 0.51 and 0.76  $\mu$ m (20 and 30  $\mu$ in.) C.L.A.

6.6 *Microscope*,<sup>4,6</sup> low-power (50 $\times$  to 60 $\times$ ), having sufficient clearance under objective to accommodate the test block. It should be fitted with a filar micrometer so that the scar width may be measured with an accuracy of  $\pm 0.05$  mm ( $\pm 0.002$  in.).

6.7 *Timer*, graduated in minutes and seconds.

## 7. Reagents

7.1 *Acetone*, reagent grade, minimum purity. (**Warning**—Extremely flammable. Vapors can cause flash fire.)

7.2 *Stoddard Solvent*, also known as Mineral Spirits, reagent grade. (**Warning**—Combustible. Vapor harmful.)

## 8. Preparation of Apparatus

8.1 Clean the apparatus with Stoddard solvent and acetone (see [7.1](#) and [7.2](#)), and blow dry. Shield the sump outlet and disconnect the oil pump to eliminate wear on the unused pump. Replace the oil reservoir with the grease feed device.

<sup>5</sup> The sole source of supply of the test blocks known to the committee at this time is Falex Corporation, 1020 Airpark Dr., Sugar Grove, IL, 60554-9585 under Part No. F-25001.

<sup>6</sup> The sole source of supply of the apparatus known to the committee at this time is Falex Corporation, 1020 Airpark Dr., Sugar Grove, IL, 60554-9585.

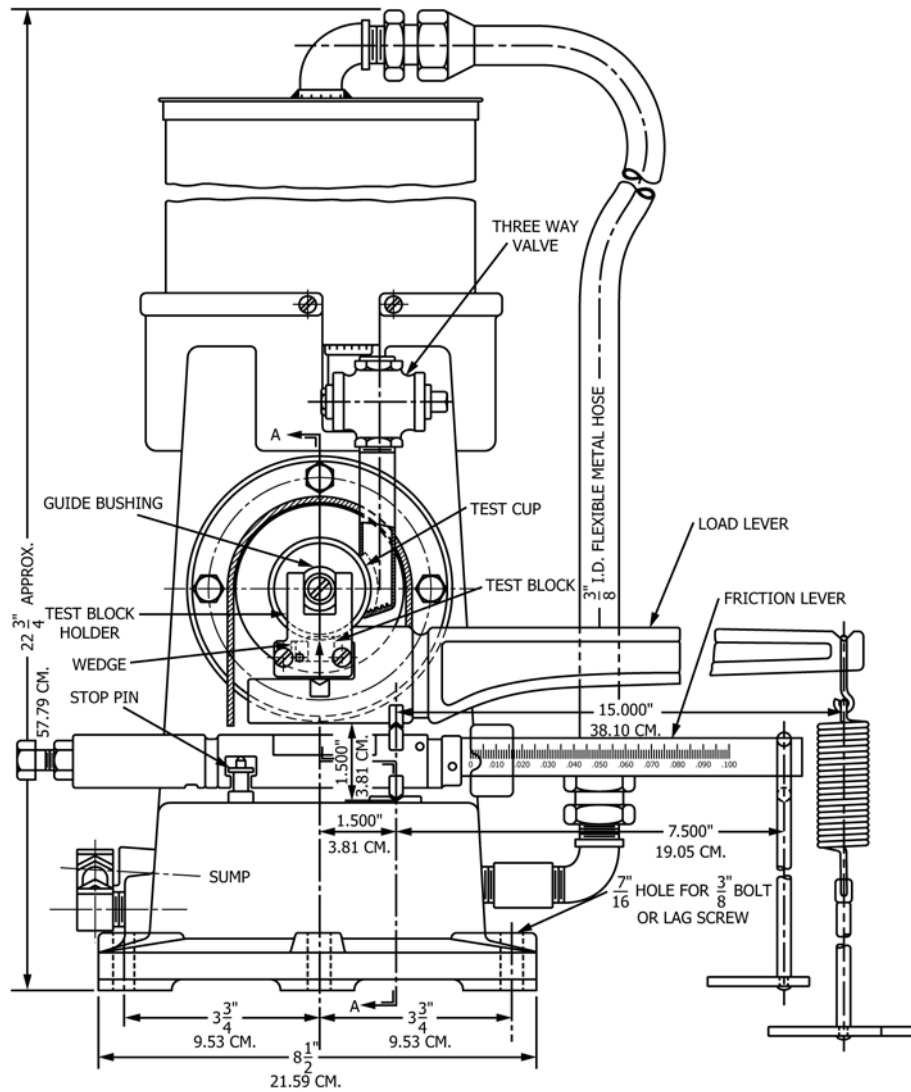

FIG. 2 Timken Tester

8.2 Select a new test cup and block, wash with Stoddard solvent, and dry with a clean soft cloth or paper. Immediately before use rinse the test cup and block with acetone and blow them dry. Do not use solvents such as carbon tetrachloride or others that may inherently possess load-carrying properties which may affect the results.

8.3 Assemble the tester carefully (Fig. 3), placing the test cup on the spindle and making certain that it is well seated, drawing it up firmly but avoiding possible distortion from excessive tightening (Note 1). Place the test block in the test block holder and adjust the levers so that all the knife edges are in proper alignment. Exercise special care in placing the stirrup of the spring-weight platform assembly (selection of which will depend on the loading device) in the groove of the load-lever arm to avoid premature shock to the test block when the load is applied. To ensure the test block, test block holder, and lever arms are properly aligned and seated, coat the test block and test cup with the grease to be tested, and rotate the machine slowly for a few revolutions either by hand or by

suitable control mechanism. If the parts are in alignment, the grease will be wiped off the cup over its entire width.

NOTE 1—At this point it is recommended that a dial indicator be used to check that the radial run-out of the cup *in situ* does not exceed 0.001 in. (0.025 mm) total indicator movement.

9. Procedure

9.1 Bring the grease to 24 ± 6°C (75 ± 10°F). Fill the grease-feeding device with grease, avoiding the inclusion of air bubbles. Apply a film of grease to the test cup and block and thoroughly grease the guide bushing with the test grease. Do not heat the grease.

9.2 Apply the grease at 24 ± 6°C (75 ± 10°F) to the test block through the grease-feed mechanism at the uniform rate of 45 ± 9 g/min (0.1 ± 0.02 lb/min). Start the motor and run for 30 s to break-in. If the equipment used is equipped with acceleration control, start the motor and gradually increase the rotational speed of the spindle to achieve 800 ± 5 rpm after 15 s. Run for a further 15 s to complete the break-in.

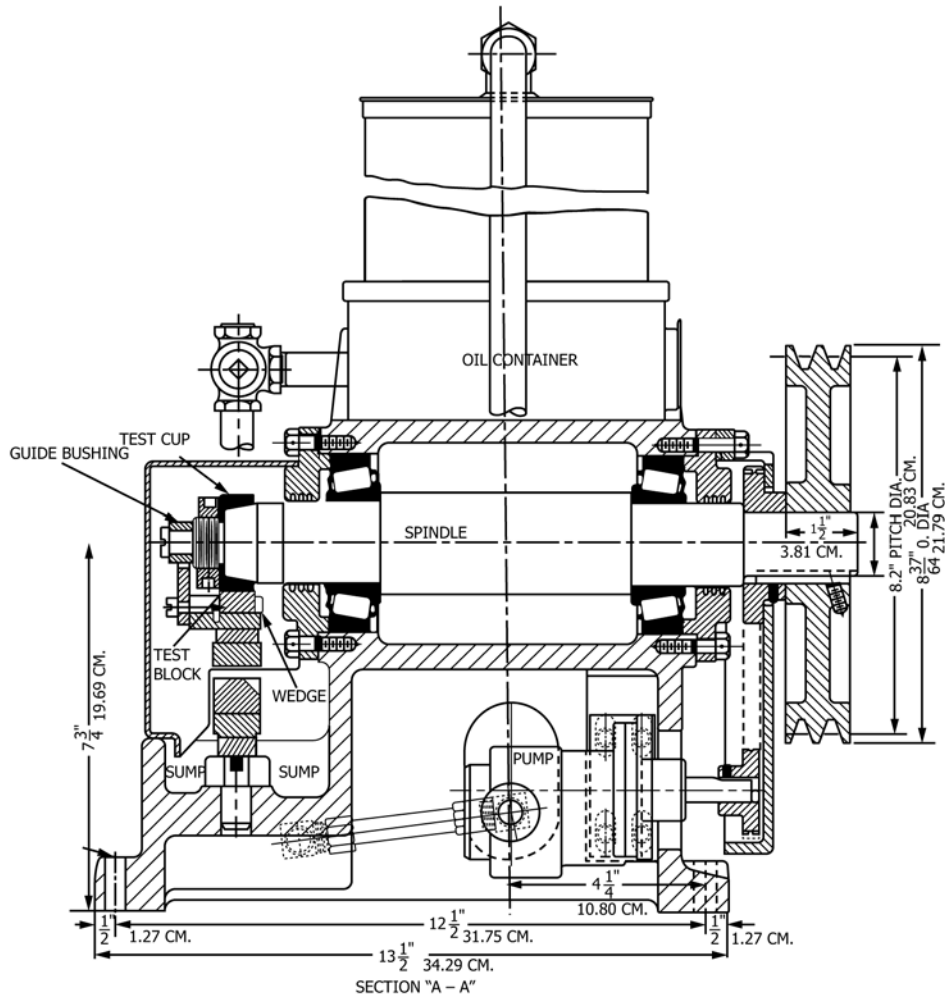

FIG. 2 Timken Tester (continued)

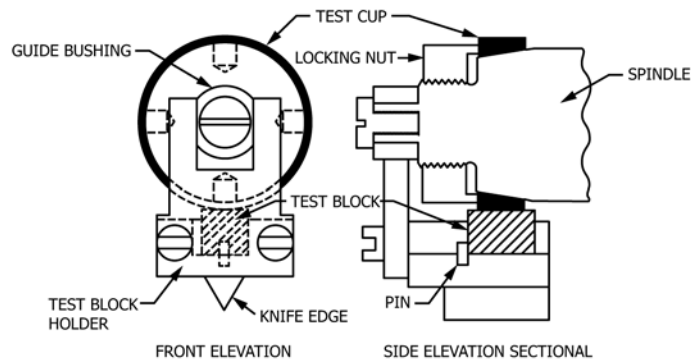

FIG. 3 Assembly of Tester Showing Test Pieces

9.3 After the break-in period of 30 s, start the timer and apply at 8.9 to 13.3 N/s (2 to 3 lbf/s), a load of 133.4 N (30 lbf). (A starting load of 133.4 N (30 lbf/s) is recommended. The load lever arm, spring, and mass (weight) carrier assembly are not considered part of the applied load.) Then allow the machine to run at  $800 \pm 5$  rpm for 10 min  $\pm$  15 s after load application is initiated, unless a score is detected before that period. Excessive noise and fluctuations in the spindle speed

indicate scoring of the test components. Stop the machine at once, turn off the supply of grease lubricant, and remove the load.

9.4 If, after the load has been applied, scoring is evident by vibration or noise, stop the tester at once, remove the load, and turn off the flow of lubricant. Since the excessive heat



developed with deep scoring may alter the surface characteristics of the entire block, discard the test block. (**Warning**—The machine and test pieces may be hot at this point and care should be exercised in their handling.)

9.5 If no scoring/scuffing is detected, allow the tester to run for 10 min ± 15 s from the start of the application of the load. At the end of the 10 min ± 15 s period, reverse the loading device and remove the load from the lever arm. Turn off the motor, allow the spindle to come to rest, then turn off the flow of grease. Remove the load lever and inspect the condition of the test block surface. The lubricant has failed at the imposed load if the wear scar indicates any scoring/scuffing or welding. Significant tapering indicates improper alignment or setup and test run should be repeated. See Fig. 1.

NOTE 2—Microscopical observations should not be used to define if scoring has occurred, but a skilled operator may use a microscope to examine the wear scar for further information.

9.6 If no score is observed, turn the test block to expose a new surface of contact and, with a new test cup, repeat the test with a load 44.5-N (10-lbf) heavier and in successive tests increase it in 44.5-N (10-lbf) increments until a load that produces a score is reached. At this point decrease the load by 22.2 N (5 lbf) for the final determination.

9.7 If a score is produced at the 133.4-N (30-lbf) load, reduce the load by 26.7-N (6-lbf) decrements until no scoring is realized. At this point, increase the load by 13.3 N (3 lbf) for the final determination.

9.8 When the wear scar evidence at any load stage makes the definition of the onset of scoring questionable, repeat the test at the same load. If the second test produces a score, record a score rating for this load. Similarly, if the second test produces no scoring, record a no score rating. If the second test again yields a questionable result, simply withhold judgment of the rating at this load stage and test the grease at the immediately next higher and lower load stages. Then assign a rating to the load stage in question which is identical to the rating obtained at the immediately next higher load stage employed (see Annex A2).

NOTE 3—Two other procedures that may be conducted with this apparatus are described by Appendix X1 and Appendix X2.

## 10. Calculation and Report

10.1 Report the OK and score values in terms of the masses (weights) placed on the mass (weight) pan hanging from the end of the load-lever arm; do not include the mass (weight) of the pan assembly. Report the values in multiples of 2.27 kg (5 lb) above 13.71 kg (30 lb) and in multiples of 1.36 kg (3 lb) below 30 lb.

10.2 When desired, the contact (unit) pressure which exists between the cup and block at the conclusion of the test may be calculated.<sup>7</sup> After the OK value has been determined, remove

<sup>7</sup> For convenience, contact (unit) pressure tables are available from Falex Corporation, 1020 Airpark Dr., Sugar Grove, IL, 60554-9585.

the test block and wash with Stoddard solvent, rinse with acetone, and blow dry. By means of a filar micrometer microscope, measure the width of the scars on those blocks which successfully carried this load. Make all measurements to 0.05 mm (0.002 in.) Calculate the contact pressure,  $C$ , as follows:

$$C, \text{ psi} = [L(X+G)]/YZ \text{ or } [20(X+G)]/Z \quad (1)$$

$$C, \text{ MPa} = 9.81 [L(X'+0.454G)]/Y'Z' \quad (2)$$

where:

- $L$  = 10 = mechanical advantage of load-lever arm,
- $G$  = load-lever constant (value is stamped on lever arm of each tester),
- $X$  = mass (weight) placed on the weight pan, lb
- $X'$  = mass (weight) placed on the weight pan, kg,
- $Y$  = length of test scar (1/2 in.),
- $Y'$  = length of test scar (12.7 mm),
- $Z$  = average width of test scar, in., and
- $Z'$  = average width of test scar, mm.

## 11. Precision and Bias

11.1 The precision of this test is not known to have been obtained in accordance with currently accepted guidelines (for example, Research Report RR:D02-1007).

11.2 The following criteria should be used for judging the acceptability of OK load results (95 % confidence):

11.2.1 *Repeatability*—Duplicate results by the same operator should be considered suspect if they differ by more than 23 % of their mean. Table X3.1, based on this level of repeatability, and the use of the load increments specified in the method, may be used to quickly check the acceptability of the results by the same operator.

11.2.2 *Reproducibility*—The results submitted by each of two laboratories should be considered suspect if they differ by more than 59 % of their mean. Table X3.2, based on this level of reproducibility and the use of the load increments specified in the method, may be used to quickly check the acceptability of two results, each from a different laboratory.

11.3 *Bias*—The procedure in Test Method D2509 for measuring load-carrying properties of lubricating grease has no bias because the value of load-carrying properties can be defined only in terms of a test method.

NOTE 4—These precision data were derived from tests by 14 laboratories on five greases whose average Timken OK loads ranged from approximately 18.14 kg to 24.98 kg (40 lb to 65 lb). These results have been published in the NLGI Spokesman, Vol. XL No. 10, January 1978, pp. 342–351.

## 12. Keywords

12.1 EP; extreme pressure; grease; grease load-carrying capacity; Timken

**ANNEXES**
**(Mandatory Information)**
**A1. TIMKEN EXTREME PRESSURE TESTER**

A1.1 *Timken Extreme Pressure Tester*—consisting essentially of a steel test cup rotating against a steel test block loaded from below. The test cup is attached to a horizontal spindle mounted in two roller bearings and driven at  $800 \pm 5$  rpm by a 2-hp (1.5-w) synchronous motor. The test block is mounted in a holder upon knife-edge bearings, designed to promote correct alignment and uniform pressure between the test cup and block. The machine must be mounted rigidly as results are affected by vibration.

A1.1.1 *Test Block Holder*, fitted with a pin, is provided with a steel wedge to hold the test block in position. It also has a pair of arms which fit around a cast iron guide bushing on the spindle. The bottom of the holder is mounted on knife edges on the load lever.

A1.1.2 *Test Cup Spindle*, tapered to receive the test cup which is locked in position by a locking nut with a left-hand thread. The spindle has a maximum radial run out of 0.013 mm (0.0005 in.); if the assembled cup and spindle has a radial run out greater than 0.025 mm (0.001 in.), test results may be affected. This value would indicate a badly worn or damaged spindle which should be replaced. Periodic checking of an assembled cup and spindle is recommended.

A1.1.3 *Lever System*, consisting of two levers: the upper or load lever and the bottom or friction lever. The load lever carries the test block holder and is mounted on knife edges on the friction lever. The friction lever, pivoted on a knife edge, is provided with a stop at the unloaded end.

A1.1.4 *Load-Lever Constant*—The mechanical advantage of the load lever is 10; that is, 0.454 kg (1 lb) placed on the notch at the outer end will exert a force of 44.5 N (10 lbf) on the test block. The effective mass (weight) of the load lever arm and mass (weight) pan system is stamped on the lever arm of each tester.

A1.1.5 *Grease Sample Feed Device*<sup>4,8</sup>—A suitable container capable of holding a sufficient quantity of test grease and fitted with a suitable piston arrangement capable of forcing the test grease through a dispensing tube and onto the test cup and block at a uniform rate of  $45 \pm 9$  g/min ( $0.1 \pm 0.02$  lb/min).

A1.2 *Loading Mechanism*<sup>4,6</sup> consists of a power-operated loading platform so arranged that the masses (weights) are applied to the end of the load lever at a uniform rate of 0.91 to

1.36 kg/s (2 to 3 lb/s), thus eliminating any errors due to a non-uniformity of load application. The masses (weights) should be applied vertically to the center of the pan at the end of the load lever. It should be noted that the loading rate is a function of the velocity of the loading mechanism and the deflection rate of the mass (weight) carrier springs. To measure the loading rate of the mechanism, the following procedure may be used.

A1.2.1 Place a piece of paper on the loading platform. Over it place the mass (weight) pan, with a 4.54 or 9.07-kg (10 or 20-lb) mass (weight) on the pan. An edge of the paper should be left exposed.

A1.2.2 Start the loading platform. When loading begins (indicated by loss of slack in the pan suspension apparatus) begin timing using a stopwatch.

A1.2.3 Grip the paper under the mass (weight) pan firmly. When the paper slides out from between the pan and platform, the stopwatch should be stopped. The time elapsed is the time to apply the load on the pan.

A1.2.4 Repeat A1.2.1 – A1.2.3 at 44.5 or 89-N (10 or 20-lbf) increments through the maximum load to be used on the testers (smaller increments may be necessary if the loading spring is very non-linear).

A1.2.5 Plot corresponding load versus time values and draw a curve through them. The slope at all points should be between 8.9 to 13.3 N/s (2 and 3 lbf/s). Alternatively, the loading rate for each load increment may be calculated as illustrated below for a 89-N (20-lbf) increment between 89 and 177.9 N (20 and 40 lbf).

Load		
lbf	N	Time to Apply, s
0	0	0
20	89	7.8
40	177.9	14.6
60	266.9	21.3

$$\text{Rate (20 to 40 lbf)} = \frac{40 \text{ lbf} - 20 \text{ lbf}}{14.6 \text{ s} - 7.8 \text{ s}} = \frac{20 \text{ lbf}}{6.8 \text{ s}} = 2.9 \text{ lbf/s (A1.1)}$$

$$(89 \text{ to } 177.9 \text{ N}) = \frac{177.9 \text{ N} - 89 \text{ N}}{14.6 \text{ s} - 7.8 \text{ s}} = \frac{88.9 \text{ N}}{6.8 \text{ s}} = 13.07 \text{ N/s (A1.2)}$$

All increments should show values in the range 2.0 to 8.9 to 13.3 N/s (3.0 lbf/s).

A1.2.6 Once the loading rate has been established, it can be adjusted, if necessary, by either changing the platform descent rate, or by switching to a spring having different elongation behavior when loaded.

<sup>8</sup> A suitable grease feeding mechanism appears in ASTM Bulletin, *ASTBA*, No. 228, February 1958, p. 32, modified to deliver the test grease at the prescribed uniform rate. A suitable device is manufactured by Falex Corp.

## A2. PROCEDURE FOR ASSIGNING RATING IN CASE OF QUESTIONABLE EVIDENCE OF SCORING

A2.1 The procedure to be followed in the assignment of a score or non-score rating to a load stage at which the evidence of the onset of scoring is questionable is illustrated by considering the following examples. In each example it is assumed that in accordance with 9.8 duplicate results have previously been obtained at the load stage in question, and that the examination of wear scars so produced made the assignment of either score or non-score ratings uncertain.

A2.1.1 If a grease is tested in duplicate at a load of 177.9 N (40 lbf) in accordance with 9.8, and the examination of both wear scars produced leaves some question regarding the onset of scoring, the operator should next test the grease at a load of 200.2 N (45 lbf). If no score is observed at this higher load, a no score rating will be entered for the 177.9 N (40 lb) load, and testing will proceed at the next usual load increment, for example, 222.4 N (50 lbf). If a score is observed at the 200.2 N (45-lbf) load, a score rating will be entered for the 177.9 N

(40 lbf) load. In this case in accordance with 9.6 the next and final test would be conducted at the 155.7-N (35-lbf) load.

A2.1.2 If a grease is tested in duplicate at a load of 106.8 N (24 lbf) in accordance with 9.8, and the examination of both wear scars produced leaves some question regarding the onset of scoring, the operator should next test the grease at a load of 120.1 N (27 lbf). If a score is observed at this higher load, a score rating will be entered for the 106.8-N (24-lbf) load, and testing will proceed at the next usual load decrement, for example, 80.1 N (18 lbf). If no score is observed at the 120.1-N (27-lbf) load, a no score rating will be entered for the 106.8-N (24-lbf) load. In this case in accordance with 9.7 no further testing would be required since no score ratings would be recorded for the 106.8 and 120.1-N (24 and 27-lbf) loads and scoring had presumably previously been observed at the (133.4-N) 30-lbf load.

## APPENDIXES

### (Nonmandatory Information)

#### X1. PROCEDURE FOR DETERMINATION OF FRICTION

X1.1 Carry out procedure as in 9.1 – 9.4.

X1.2 Proceed as in 9.5, but run for 9 min. If no scoring has occurred, obtain the friction reading by adding weights to the friction lever weight pan and by moving the sliding weight along the friction lever until the friction lever moves from the stop pin. Stop the machine.

X1.3 Report the coefficient of friction,  $\mu$ , calculated for any load on the load lever below the actual score load by the use of the following equation:

$$\mu = \frac{9.45 (B + R)}{10 (X + G) - 2.5 (B + R)} \quad (\text{X1.1})$$

where:

$B$  = mass (weight) on the friction lever pan, lb,

$R$  = friction lever sliding weight reading, lb,  
 $X$  = mass (weight) on the load lever pan, lb, and  
 $G$  = load lever constant, lb (see Note X1.1) or

$$\mu = \frac{9.45 (B' + R')}{10 (X' + G') - 2.5 (B' + R')} \quad (\text{X1.2})$$

where:

$B'$  = mass (weight) on the friction lever pan, kg,  
 $R'$  = friction lever sliding weight reading, kg,  
 $X'$  = mass (weight) on the load lever pan, kg, and  
 $G'$  = load lever constant, kg (see Note X1.1)

NOTE X1.1—The load lever constant is stamped on the lever arm of each tester. It is normally given in pounds, and is typically around 1.70 (lb). To obtain  $G'$ , multiply the value in pounds by 0.454.

X1.4 The precision of this determination has not been established.

## X2. PROCEDURE FOR MEASUREMENT OF RESISTANCE TO WEAR OR ABRASIVE PROPERTIES, OR BOTH

X2.1 Prepare the apparatus as in Section 8, but before placing the cup on the spindle and the block in the test block holder, weigh these components accurately to the nearest 0.0001 g.

X2.2 Proceed as in Section 9 and where no scoring has occurred remove the cup and block, clean with solvents, (see 8.2), and weigh accurately to the nearest 0.0001 g.

X2.3 Subtract the final weights of the test cup and block from the weights of these components obtained before the test.

X2.4 Report the results as the loss in weight in milligrams, the load, and the duration of the test.

X2.5 The precision of this determination has not been established.

## X3. TABLES FOR CHECKING ACCEPTABILITY OF DUPLICATE RESULTS

X3.1 See Table X3.1 and Table X3.2 for duplicate results.

**TABLE X3.2 A Guide to Acceptability of Results by Each of Two Laboratories**

Mean OK Value for Two Results		Reject Results if Their Difference Exceeds:	
kg	lb	kg	lb
Less than 9.07	Less than 20.0	4.08	9
9.07 to 12.25	20.0 to 27.0	5.44	12
12.47 to 13.61	27.5 to 30.0	6.80	15
13.83 to 17.69	30.5 to 39.0	8.16	18
17.92 to 22.91	39.5 to 50.5	11.34	25
23.13 to 26.31	51.0 to 58.0	13.61	30
26.54 to 30.84	58.5 to 68.0	15.88	35
More than 30.84	More than 68.0	18.15	40

**TABLE X3.1 A Guide to Acceptability of Duplicate Results by the Same Operator**

Mean OK Value for Two Results		Reject Results if Their Difference Exceeds:	
kg	lb	kg	lb
Less than 12.25	Less than 27.0	1.36	3
12.25 to 19.05	27.0 to 42.0	2.72	6
19.28 to 29.48	42.5 to 65	4.54	10
More than 29.48	More than 65	6.80	15

## SUMMARY OF CHANGES

Subcommittee D02.G0 has identified the location of selected changes to this standard since the last issue (D2509 – 03(2008)) that may impact the use of this standard. (Approved Oct. 1, 2014.)

(1) Revised 3.1.2.1, 4.1, 4.2, 9.2, 9.5, and footnote 7.

*ASTM International takes no position respecting the validity of any patent rights asserted in connection with any item mentioned in this standard. Users of this standard are expressly advised that determination of the validity of any such patent rights, and the risk of infringement of such rights, are entirely their own responsibility.*

*This standard is subject to revision at any time by the responsible technical committee and must be reviewed every five years and if not revised, either reapproved or withdrawn. Your comments are invited either for revision of this standard or for additional standards and should be addressed to ASTM International Headquarters. Your comments will receive careful consideration at a meeting of the responsible technical committee, which you may attend. If you feel that your comments have not received a fair hearing you should make your views known to the ASTM Committee on Standards, at the address shown below.*

*This standard is copyrighted by ASTM International, 100 Barr Harbor Drive, PO Box C700, West Conshohocken, PA 19428-2959, United States. Individual reprints (single or multiple copies) of this standard may be obtained by contacting ASTM at the above address or at 610-832-9585 (phone), 610-832-9555 (fax), or service@astm.org (e-mail); or through the ASTM website (www.astm.org). Permission rights to photocopy the standard may also be secured from the Copyright Clearance Center, 222 Rosewood Drive, Danvers, MA 01923, Tel: (978) 646-2600; http://www.copyright.com/*